



Super Low Noise GaAs FETs

FEATURES

- Low Noise Figure:
NF = 0.5 dB Typical at 12 GHz
- High Associated Gain:
Ga = 12 dB Typical at 12 GHz
- Lg = 0.25 μm , Wg = 300 μm
- All-Gold Metallization for High Reliability
- 100 % DC Tested

PHOTO ENLARGEMENT

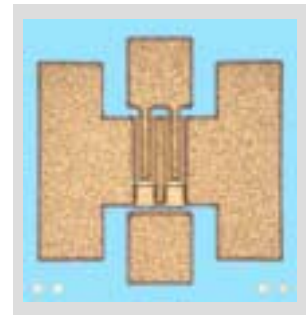

DESCRIPTION

The TC1202 is a GaAs Pseudomorphic High Electron Mobility Transistor (PHEMT) chip, which has very low noise figure and high associated gain. The device can be used in circuits up to 40 GHz and suitable for low noise application including a wide range of commercial and military applications. All devices are 100% DC tested to assure consistent quality. All bond pads are gold plated for either thermo-compression or thermo-sonic wire bonding.

ELECTRICAL SPECIFICATIONS (T_A=25 °C)

Symbol	CONDITIONS	MIN	TYP	MAX	UNIT
NF	Noise Figure at V _{DS} = 4 V, I _{DS} = 25 mA, f = 12GHz		0.5	0.7	dB
G _a	Associated Gain at V _{DS} = 4 V, I _{DS} = 25 mA, f = 12GHz	11	12		dB
I _{DSS}	Saturated Drain-Source Current at V _{DS} = 2 V, V _{GS} = 0 V		90		mA
g _m	Transconductance at V _{DS} = 2 V, V _{GS} = 0 V		100		mS
V _p	Pinch-off Voltage at V _{DS} = 2 V, I _D = 0.6 mA		-1.0		Volts
BV _{DGO}	Drain-Gate Breakdown Voltage at I _{DGO} = 0.15 mA	5	8		Volts
R _{th}	Thermal Resistance		43		°C/W

TC1202

ABSOLUTE MAXIMUM RATINGS (T_A=25 °C)

Symbol	Parameter	Rating
V _{DS}	Drain-Source Voltage	5 V
V _{GS}	Gate-Source Voltage	-3.0 V
I _{DS}	Drain Current	I _{DSS}
I _{GS}	Gate Current	300 μA
P _{in}	RF Input Power, CW	17 dBm
P _T	Continuous Dissipation	300 mW
T _{CH}	Channel Temperature	175 °C
T _{STG}	Storage Temperature	- 65 °C to +175 °C

TYPICAL NOISE PARAMETERS (T_A=25 °C)

V_{DS} = 4 V, I_{DS} = 25 mA

Frequency (GHz)	NF _{opt} (dB)	G _A (dB)	Γ _{opt}		Rn/50
			MAG	ANG	
2	0.31	20.6	0.90	10	0.64
4	0.37	17.2	0.81	20	0.45
6	0.41	14.8	0.74	37	0.35
8	0.47	13.1	0.69	57	0.29
10	0.52	12.1	0.64	77	0.24
12	0.58	11.4	0.58	95	0.20
14	0.71	10.8	0.55	113	0.16
16	0.88	10.4	0.52	130	0.11
18	1.04	9.9	0.51	151	0.08

CHIP DIMENSIONS

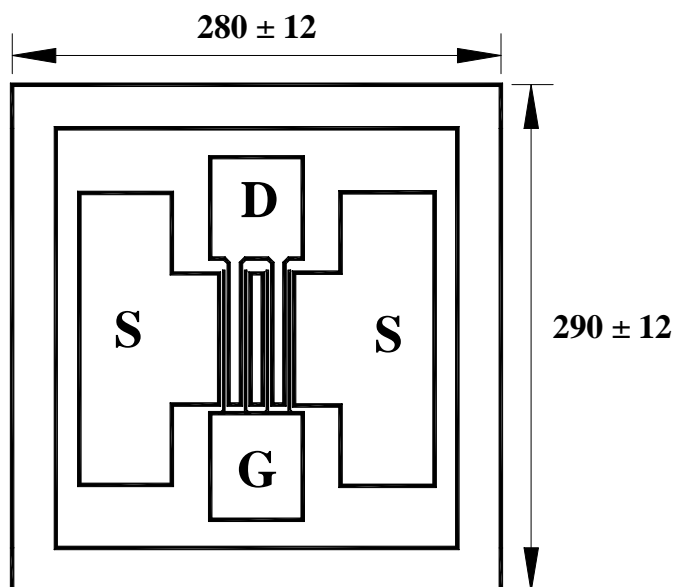

Units: Micrometers
Chip Thickness: 100

Gate Pad: 55 x 60
Drain Pad: 55 x 60
Source Pad: 55 x 169



TYPICAL SCATTERING PARAMETERS (T_A=25 °C)

V_{DS} = 4 V, I_{DS} = 25 mA

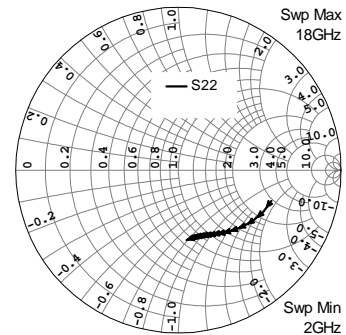
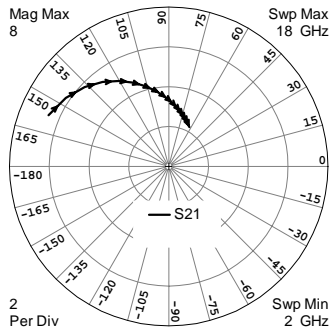
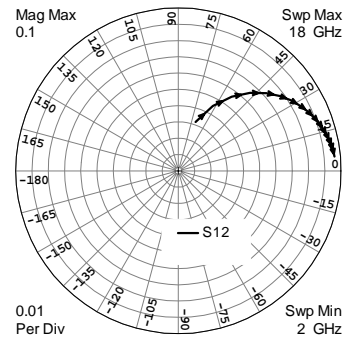
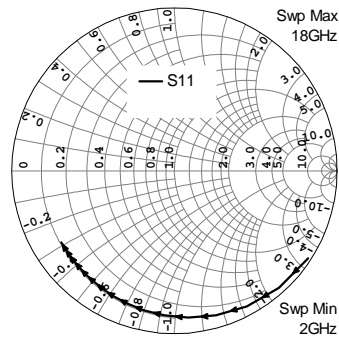

FREQUENCY (GHz)	S11		S21		S12		S22	
	MAG	ANG	MAG	ANG	MAG	ANG	MAG	ANG
2	0.9823	-33.16	6.5659	156.94	0.0318	70.67	0.6019	-18.38
3	0.9641	-48.24	6.2124	146.39	0.0451	61.99	0.5794	-26.63
4	0.9438	-61.87	5.8010	136.77	0.0562	54.23	0.5540	-33.99
5	0.9239	-73.98	5.3750	128.09	0.0650	47.41	0.5288	-40.46
6	0.9058	-84.62	4.9624	120.28	0.0720	41.46	0.5056	-46.12
7	0.8900	-93.94	4.5784	113.25	0.0775	36.28	0.4855	-51.07
8	0.8766	-102.10	4.2290	106.86	0.0818	31.75	0.4687	-55.44
9	0.8654	-109.26	3.9151	101.02	0.0852	27.76	0.4551	-59.33
10	0.8561	-115.58	3.6347	95.63	0.0878	24.22	0.4445	-62.83
11	0.8485	-121.18	3.3847	90.61	0.0899	21.04	0.4367	-66.01
12	0.8423	-126.18	3.1617	85.91	0.0916	18.18	0.4311	-68.94
13	0.8371	-130.67	2.9623	81.47	0.0929	15.57	0.4276	-71.66
14	0.8329	-134.73	2.7836	77.25	0.0940	13.18	0.4259	-74.21
15	0.8295	-138.41	2.6227	73.22	0.0948	10.97	0.4256	-76.61
16	0.8267	-141.77	2.4775	69.34	0.0955	8.92	0.4267	-78.89
17	0.8245	-144.86	2.3458	65.61	0.0960	7.00	0.4289	-81.07
18	0.8227	-147.71	2.2260	62.00	0.0964	5.19	0.4321	-83.16

• The data does not include gate, drain and source bond wires.

TC1202

SMALL SIGNAL MODEL, $V_{DS} = 4\text{ V}$, $I_{DS} = 25\text{ mA}$

SCHEMATIC

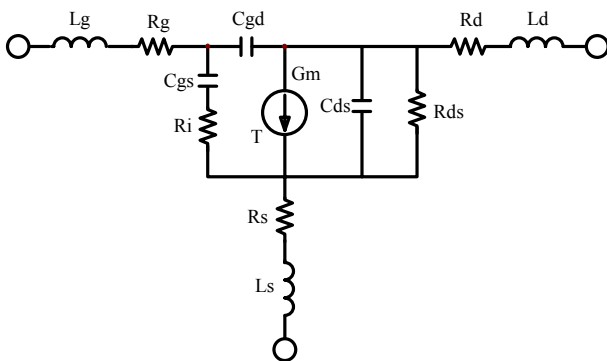

PARAMETERS

Parameters		Parameters	
Lg	0.04473 nH	Rs	1.12 Ohm
Rg	0.79 Ohm	Ls	0.0005 nH
Cgs	0.361 pF	Cds	0.0838 pF
Ri	1.47 Ohm	Rds	193.0 Ohm
Cgd	0.0310 pF	Rd	0.920 Ohm
Gm	94.9 mS	Ld	0.0242 nH
T	2.13 psec		

CHIP HANDLING

DIE ATTACHMENT: Conductive epoxy or eutectic die attach is recommended. Eutectic die attach can be accomplished with Au-Sn (80%Au-20%Sn) perform at stage temperature: $290^{\circ}\text{C} \pm 5^{\circ}\text{C}$; Handling Tool: Tweezers; Time: less than 1 min.

WIRE BONDING: The recommended wire bond method is thermocompression bonding with 0.7 to 1.0 mil (0.018 to 0.025 mm) gold wire. Stage temperature: 220°C to 250°C ; Bond Tip Temperature: 150°C ; Bond Force: 20 to 30 gms depending on size of wire and Bond Tip Temperature.

HANDLING PRECAUTIONS: The user must operate in a clean, dry environment. Care should be exercised during handling avoid damage to the devices. Electrostatic Discharge (ESD) precautions should be observed at all stages of storage, handling, assembly, and testing. The static discharge must be less than 300V.