

G6853 Single Output Hall Effect Switch IC

Description

The G6853 is an integrated Hall Effect switch sensor with output pull-high resistor driver designed for electronic commutation of brushless DC motor applications and contactless switches. The device includes an on-chip Hall voltage generator for magnetic sensing, a comparator that amplifies the Hall voltage, and a Schmitt trigger to provide switching hysteresis for noise rejection, and output driver with pull-high resistor. An internal bandgap regulator is used to provide temperature compensated supply voltage for internal circuits and allows a wide operating supply range.

If a magnetic flux density larger than threshold Bop, DO is turned on (low). The output state is held until a magnetic flux density reversal falls below Brp causing DO to be turned off (high).

The G6853 is rated for operation over temperature range from -40 °C to 150 °C and voltage range from 3.5V to 28V. The devices are available in low cost die forms or rugged 3 pin SIP packages.

Features

- * Wide range of supply voltage:3.5V to 28V.
- * Internal bandgap regulator allows temperature compensated operations and a wide operating voltage range.
- * High sensitivity with a small magnet.
- * TTL and MOS ICs directly drivable by output.
- * Build in protection diode for chip reverse power connecting.

Application

- | | |
|---------------------|------------------------|
| 1) Current Limit | 4) Rotation Sensors |
| 2) Limit Switch | 5) Revolution Counting |
| 3) Position Sensors | 6) Speed Measurement |

Package Dimensions

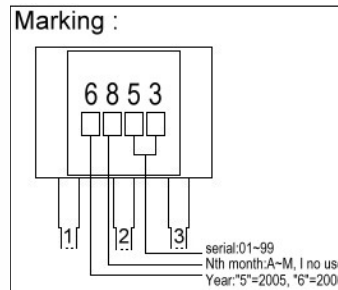
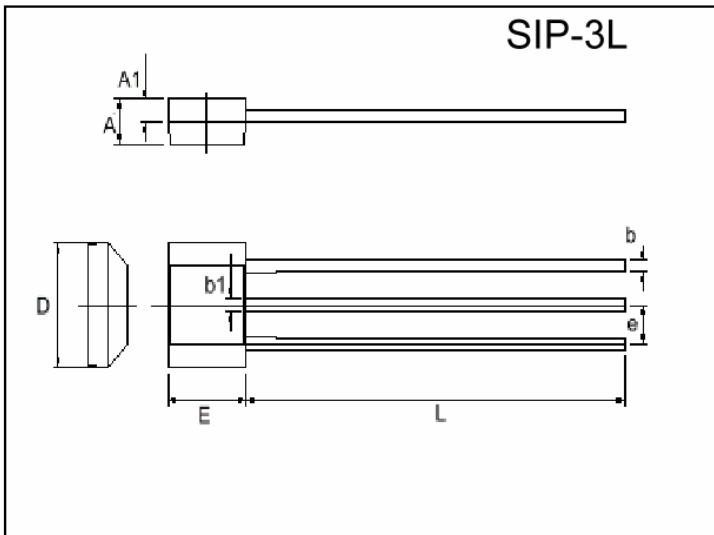

REF.	Millimeter		REF.	Millimeter	
	Min.	Max.		Min.	Max.
A	1.245	1.753	D	3.962	4.216
A1	0.750REF.		E	2.870	3.124
b	0.330	0.432	L	13.60	15.60
b1	0.406	0.508	e	1.27 REF.	

Functional Block Diagrams

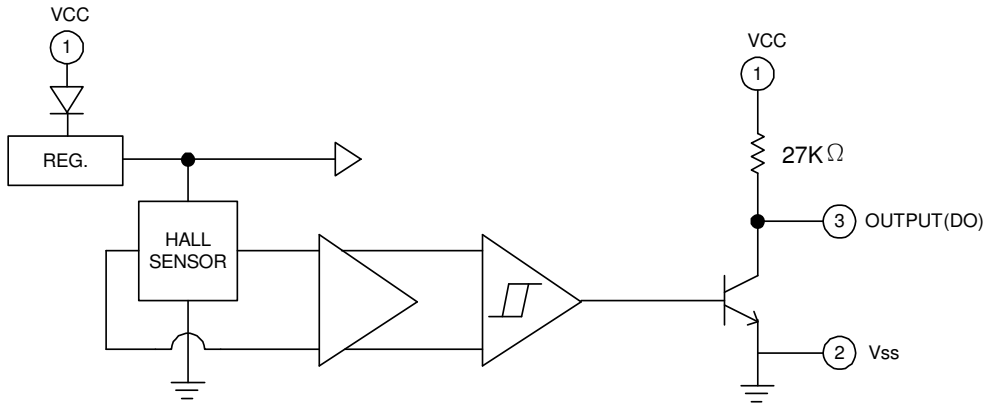

Pin Descriptions

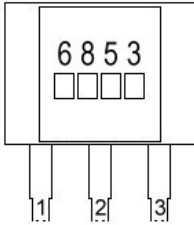

Name	P/I/O	Pin#	Description
Vcc	P	1	Positive power supply
Vss	P	2	Ground
DO	O	3	Output Pin

Absolute Maximum Ratings at Ta = 25°C

Parameter	Symbol	Value	Unit
Supply Voltage	Vcc	28V	V
Reverse Vcc Polarity Voltage	V _{RCC}	-28V	V
Magnetic flux density	B	Unlimited	
Output OFF Voltage	V _{ce}	35	V
Output ON Current	I _c Continuous	25	mA
Operating Temperature Range	T _a	-40~150	°C
Storage Temperature Range	T _s	-65~150	°C
Package Power Dissipation	PD	250	mW
Maximum Junction Temp.	T _j	175	°C

Electrical Characteristics (TA=+25°C)

Parameter	Symbol	Test Conditions	Min	Typ.	Max.	Unit
Supply Voltage	Vcc	-	3.5	-	28	V
Low output voltage	V _{OL}	Vcc=16V, I _o =12mA, B=300 Gauss	-	-	0.4	V
		Vcc=3.6V, I _o =12mA, B=300 Gauss	-	-	0.4	V
High output voltage	V _{OH}	Vcc=16V, I _o =-30μA, B=100 Gauss	14.6	-	-	V
		Vcc=3.6V, I _o =-30μA, B=100 Gauss	2.2	-	-	V
Output Leakage Current	I _{ceX}	Vcc=16V, V _{ce} =16V	-	<0.1	10	μA
Output Short-circuit Current	-I _{OS}	Vcc=16V, V _o =0V, B=100 Gauss	0.4	-	0.9	mA
Supply Current	I _{CC}	Vcc=24V, Output Open	-	5	10	mA
Output Rise Time	t _r	Vcc=16V, R _L =820Ω CL=20pF	-	0.3	1.5	us
Output Falling Time	t _f	Vcc=16V, R _L =820Ω CL=20pF	-	0.3	1.5	us

Test Circuit

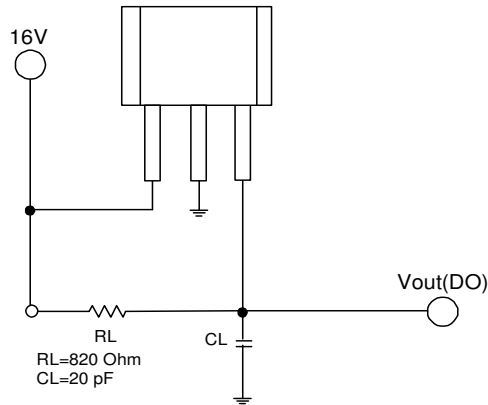

Power dissipation vs. Environment Temperature

Ta(°C)	25	50	60	70	80	85	90	95	100	105	110	115	125	150
Pd(mW)	275	262	257	252	242	237	232	227	222	212	202	192	182	100

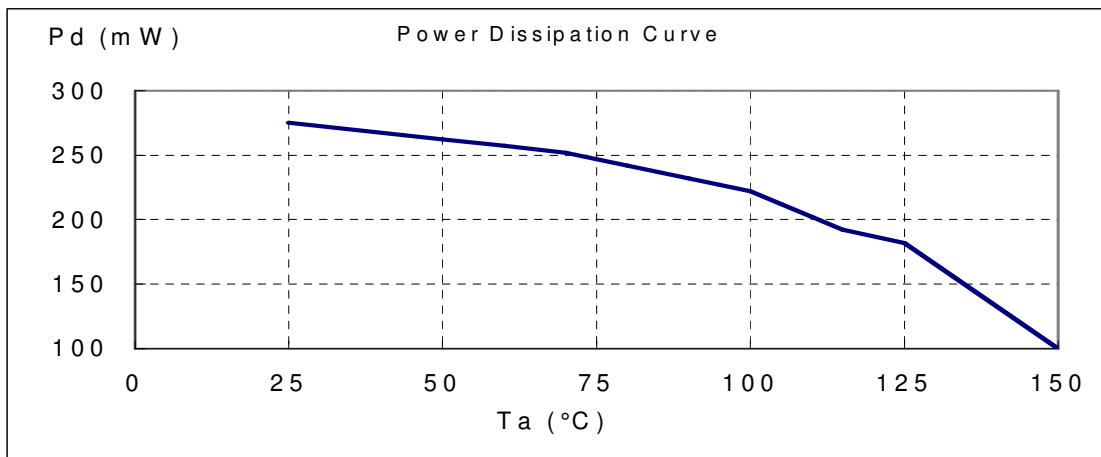

Electrical Characteristics Curves

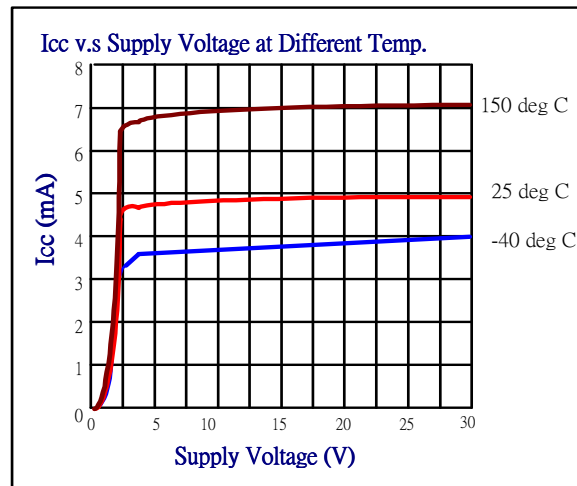
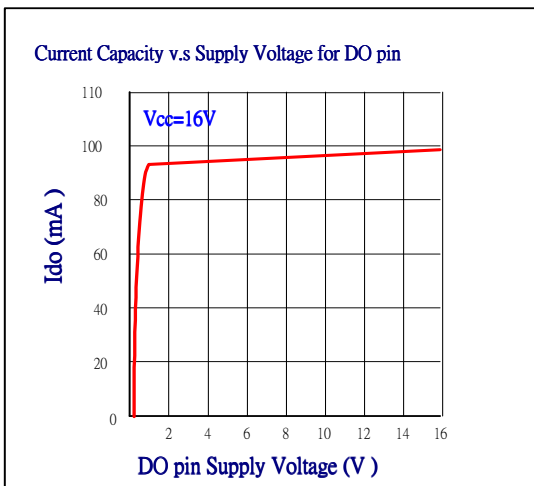

Current capacity vs. supply voltage for DO pin

Icc v.s Vcc at Different Temp

Magnetic Characteristics

Characteristic		Symbol	Ta=+25°C		Ta=0°C to +70°C		Unit
			Min	Max	Min	Max	
Operate Point	G6853	Bop	150	300	150	300	Gauss
Release Point	G6853	Brp	100	-	100	-	Gauss
Hysteresis	G6853	Bhys	30	60	30	60	Gauss

Hysteresis Characteristics

G6853

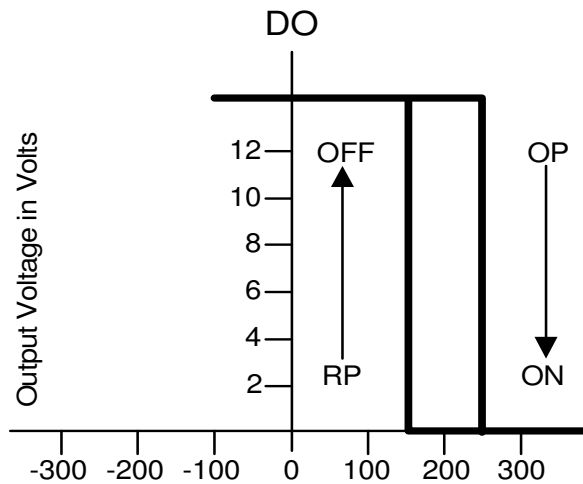

Magnetic Flux Density in Gauss

Package Information

Active Area Depth

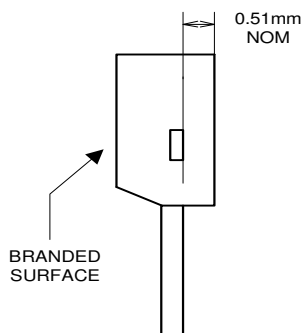

Package Sensor Location

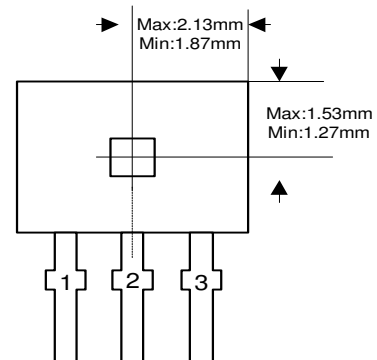

Important Notice:

- All rights are reserved. Reproduction in whole or in part is prohibited without the prior written approval of GTM.
- GTM reserves the right to make changes to its products without notice.
- GTM semiconductor products are not warranted to be suitable for use in life-support Applications, or systems.
- GTM assumes no liability for any consequence of customer product design, infringement of patents, or application assistance.

Head Office And Factory:

- **Taiwan:** No. 17-1 Tatung Rd. Fu Kou Hsin-Chu Industrial Park, Hsin-Chu, Taiwan, R. O. C.
- TEL : 886-3-597-7061 FAX : 886-3-597-9220, 597-0785
- **China:** (201203) No.255, Jang-Jiang Tsai-Lueng RD. , Pu-Dung-Hsin District, Shang-Hai City, China
- TEL : 86-21-5895-7671 ~ 4 FAX : 86-21-38950165