



DUAL JK FLIP-FLOP WITH SET AND CLEAR

The SN54/74LS76A offers individual J, K, Clock Pulse, Direct Set and Direct Clear inputs. These dual flip-flops are designed so that when the clock goes HIGH, the inputs are enabled and data will be accepted. The Logic Level of the J and K inputs will perform according to the Truth Table as long as minimum set-up times are observed. Input data is transferred to the outputs on the HIGH-to-LOW clock transitions.

MODE SELECT — TRUTH TABLE

OPERATING MODE	INPUTS				OUTPUTS	
	S_D	C_D	J	K	Q	\bar{Q}
Set	L	H	X	X	H	L
Reset (Clear)	H	L	X	X	L	H
*Undetermined	L	L	X	X	H	H
Toggle	H	H	h	h	q	q
Load "0" (Reset)	H	H	l	h	L	H
Load "1" (Set)	H	H	h	l	H	L
Hold	H	H	l	l	q	q

*Both outputs will be HIGH while both S_D and C_D are LOW, but the output states are unpredictable if S_D and C_D go HIGH simultaneously.

H, h = HIGH Voltage Level

L, l = LOW Voltage Level

X = Immaterial

l, h (q) = Lower case letters indicate the state of the referenced input (or output) one setup time prior to the HIGH-to-LOW clock transition

LOGIC DIAGRAM

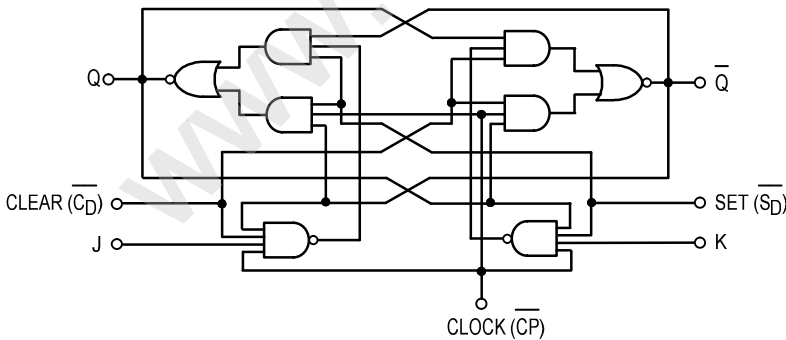

LOGIC SYMBOL

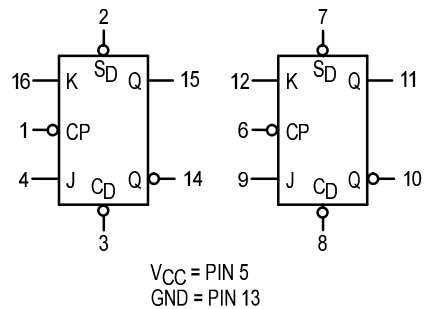

SN54/74LS76A

DUAL JK FLIP-FLOP WITH SET AND CLEAR
LOW POWER SCHOTTKY

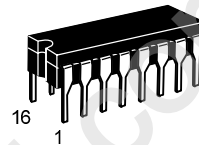

J SUFFIX
CERAMIC
CASE 620-08

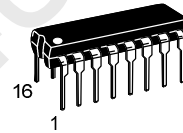

N SUFFIX
PLASTIC
CASE 648-08

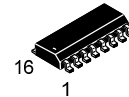

D SUFFIX
SOIC
CASE 751B-03

ORDERING INFORMATION

SN54LSXXJ Ceramic
SN74LSXXN Plastic
SN74LSXXD SOIC

SN54/74LS76A

GUARANTEED OPERATING RANGES

Symbol	Parameter		Min	Typ	Max	Unit
V _{CC}	Supply Voltage	54	4.5	5.0	5.5	V
		74	4.75	5.0	5.25	
T _A	Operating Ambient Temperature Range	54	-55	25	125	°C
		74	0	25	70	
I _{OH}	Output Current — High	54, 74			-0.4	mA
I _{OL}	Output Current — Low	54			4.0	mA
		74			8.0	

DC CHARACTERISTICS OVER OPERATING TEMPERATURE RANGE (unless otherwise specified)

Symbol	Parameter	Limits			Unit	Test Conditions	
		Min	Typ	Max			
V _{IH}	Input HIGH Voltage	2.0			V	Guaranteed Input HIGH Voltage for All Inputs	
V _{IL}	Input LOW Voltage	54		0.7	V	Guaranteed Input LOW Voltage for All Inputs	
		74		0.8			
V _{IK}	Input Clamp Diode Voltage		-0.65	-1.5	V	V _{CC} = MIN, I _{IN} = -18 mA	
V _{OH}	Output HIGH Voltage	54	2.5	3.5	V	V _{CC} = MIN, I _{OH} = MAX, V _{IN} = V _{IH} or V _{IL} per Truth Table	
		74	2.7	3.5	V		
V _{OL}	Output LOW Voltage	54, 74		0.25	0.4	V	I _{OL} = 4.0 mA V _{CC} = V _{CC} MIN, V _{IN} = V _{IL} or V _{IH} per Truth Table
		74		0.35	0.5	V	
I _{IH}	Input HIGH Current	J, K Clear Clock			20 60 80	μA	V _{CC} = MAX, V _{IN} = 2.7 V
		J, K Clear Clock			0.1 0.3 0.4	mA	V _{CC} = MAX, V _{IN} = 7.0 V
I _{IL}	Input LOW Current	J, K Clear, Clock			-0.4 -0.8	mA	V _{CC} = MAX, V _{IN} = 0.4 V
I _{OS}	Short Circuit Current (Note 1)		-20		-100	mA	V _{CC} = MAX
I _{CC}	Power Supply Current				6.0	mA	V _{CC} = MAX

Note 1: Not more than one output should be shorted at a time, nor for more than 1 second.

AC CHARACTERISTICS (T_A = 25°C, V_{CC} = 5.0 V)

Symbol	Parameter	Limits			Unit	Test Conditions
		Min	Typ	Max		
f _{MAX}	Maximum Clock Frequency	30	45		MHz	V _{CC} = 5.0 V C _L = 15 pF
t _{PLH} t _{PHL}	Clock, Clear, Set to Output		15	20	ns	
			15	20	ns	

AC SETUP REQUIREMENTS (T_A = 25°C)

Symbol	Parameter	Limits			Unit	Test Conditions
		Min	Typ	Max		
t _W	Clock Pulse Width High	20			ns	V _{CC} = 5.0 V
t _W	Clear Set Pulse Width	25			ns	
t _S	Setup Time	20			ns	
t _H	Hold Time	0			ns	

FAST AND LS TTL DATA