

SD

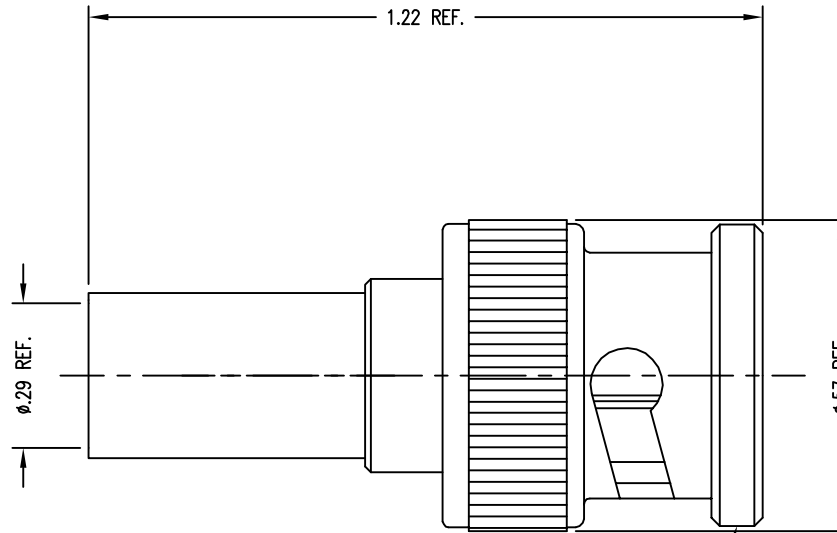

STAMP: KINGS 2065-10-9  
YRWK (DATE CODE)

NOTES:

1. FOR USE WITH BELDEN 1694A CABLE.
2. FOR CABLING INSTRUCTIONS SEE 3-661-4
3. FOR CRIMPING USE DIE KTH-2325.
4. INTERFACE PER MIL-STD-348, FIG 301.1, AS APPLICABLE.
5. MATERIALS:
  - INSULATOR-TEFLON, ASTM-D-4894
  - GASKET-SILICONE RUBBER, ZZ-R-765
  - SPRING WASHER } BER. COP., ASTM-B-196
  - OUTER CONTACT }
  - K-GRIP SLEEVE-COMMERCIAL BRONZE, ASTM-B-135
  - ALL OTHER METAL PARTS-BRASS, ASTM-B16
6. FINISHES:
  - CENTER CONTACTS-GOLD PLATE PER MIL-G-45204
  - SPRING WASHER-SILVER PLATE PER QQ-S-365
  - ALL OTHER METAL PARTS-KINGS TARNISH RESISTANT NICKEL FINISH (TR-5)
7. MARK PACKAGE: KINGS 2065-10-9
8. ELECTRICAL CHARACTERISTICS:
  - NOMINAL IMPEDANCE: 75 OHMS
  - WORKING VOLTAGE: 500 VRMS
  - FREQUENCY RANGE: DC TO 6 GHz
  - RETURN LOSS: UP TO 1.5GHz, <-30dB
  - UP TO 3.0GHz, <-22dB
  - UP TO 6.0GHz, <-18dB
9. COMPLIANT TO SMPTE 424M (3G-SDI) SPECIFICATION

SD

REVISIONS	
ISSUE	CHANGES
0	ER 37747 DCT 12/18/98
1	CN 37837 C TML 05/21/99
2	CN 37933 D TML 11/09/99
3	CN 38011 D HVN 05/23/00
4	CN 38027 E TML 07/07/00
5	CN 38495 E TML 02/01/02
6	CN 38637 E TML 08/22/02
H	ER 14183 PSM 03/09/09
	ER 22156 DW 03/02/10
2065109S	
SCALE 4:1	
APPROX SURFACE AREA	
WAS: E-19649	
USED ON	
REF:	
PL, 75 BNC	
DRAWN MRM	DATE 04/15/98
DESIGN LI	DATE 04/15/98
APPR.	DATE
KINGS by WINCHESTER	Winchester Electronics 82 Barnes Industrial Road North Wallingford, CT 06492
	B SIZE
2065-10-9	

2065-10-9 SD