



# TMPA 8823-5VA4 SERVICE MANUAL

## CONTENT

(1) General-----	1
(2) Frame Chart-----	fig.1
(3) IC Function Introduction -----	1
3.1 N501 TMPA8823-----	2
3.2 N002 ST4053 -----	3
3.3 N301 LA78040 -----	4
3.4 N601 AN7522-----	4
(4) I <sup>2</sup> C Bus Control -----	5
4.1 Menu Entry -----	5
4.2 Item Introduction -----	5
(5) IC Voltage -----	8
(6) Trouble shorting-----	9

**(1) General**

This chassis consists of main IC TMPA8823-5VA4, ST4053. TMPA8823-5VA4 is an integrated circuit for a PAL TV. A MCU and a TV signal processor (SP) are integrated in a 64-pin shrink DIP package. The MCU contains 8-bit CPU, ROM, RAM, I/O ports, timer/counters, A/D converters, an on-screen display controller, remote control interfaces, IIC bus interfaces. The TV signal processor contains PIF, SIF, Video, multi-standard chroma, Sync, RGB processors.

**(2) Frame Chart (see fig.1)**

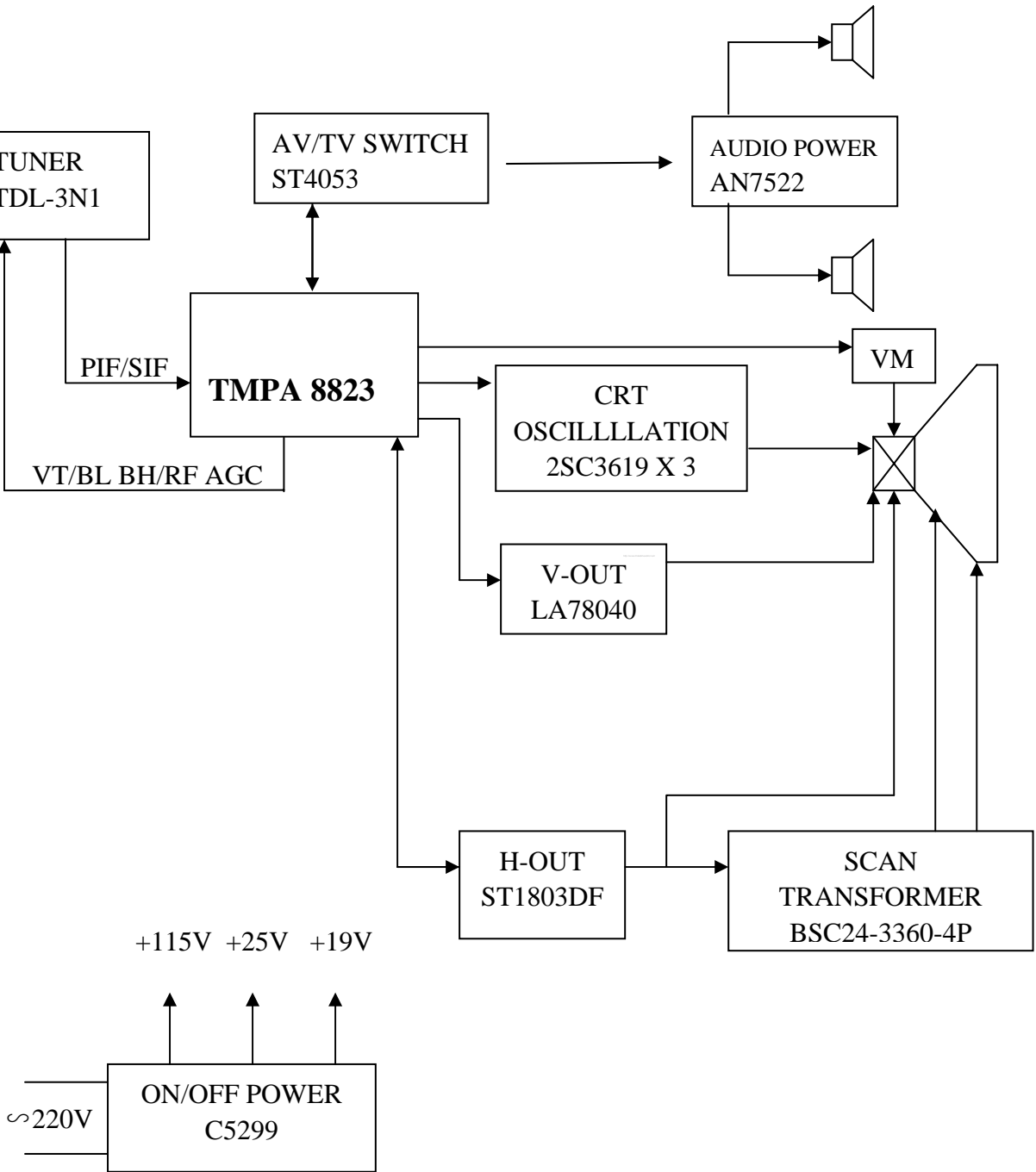

**fig.1**

### (3) IC Function Introduction

#### 3.1 N501 TMPA8823-5VA4 Function: MCU and SP

Icon	PIN	Description
SDA2	1	IIC bus serial data input/output
MUTE	2	Mute Output
KEY	3	Key input
DVSS	4	GND connection
RESET	5	Reset signal input
XOUT	6	8 MHz oscillator connection
XIN	7	8 MHz oscillator connection
TEST	8	GND connection
DVDD	9	5V power supply
VVSS	10	GND connection
TV GND	11	GND terminal for Analog block
FBP IN	12	Input terminal for FBP
H.OUT	13	Horizontal driving pulse output
H.AFC1	14	H AFC filter connection
V.SAW	15	Terminal to be connected capacitor to generate V saw signal
V.OUT	16	Vertical driving pulse output
H.Vcc(9V)	17	Vcc terminal for DEF circuit
NC	18	No use
Cb in	19	Input terminal for Cb signal
Y in	20	Input terminal for Y signal
Cr in	21	Input terminal for Cr signal
DIG GND	22	GND terminal for Digital block
C in	23	Input terminal for Chroma signal
V2 in	24	Input terminal for Video signal
DIG Vdd	25	Vcc terminal for Digital block
CW out	26	Output terminal for fsc wave signal
ABCL in	27	Input terminal for ABL/ACL control
EW out	28	Output terminal for east-west correction signal
IF Vvv(9V)	29	Vcc terminal for IF circuit
TV out	30	Detected PIF signal output terminal
SIF out	31	Detected SIF signal output terminal
DC NF	34	Terminal to be connected capacitor for DC Negative feedback
PIF PLL	35	Loop filter for PIF PLL connection
IF Vvv(5V)	36	Vcc terminal for IF circuit
REG FIL	37	Terminal to be connected capacitor for stabilizing internal bias
DE-EMP	38	Terminal to be connected capacitor for SIF Det De-Emphasis
IF AGC	39	IF AGC filter connection
IF GND	40	GND terminal for IF circuit

IF IN	41	Input terminals for IF signals
IF IN	42	Input terminals for IF signals
RF AGC	43	RF AGC control level output
YC Vcc	44	Vcc terminal for Y/C circuit
Vsm out	45	Output terminal for Vsm signal
Black DET	46	Terminal to be connected with Black Det filter for black stretch
APC Filter	47	Terminal to be connected with APC filter for Chroma demodulation
IK IN	48	Sense ACB cathode current input
RGB Vcc	49	Vcc terminal for RGB circuit
R OUT	50	Output terminal for R signal
G OUT	51	Output terminal for G signal
B OUT	52	Output terminal for B signal
TV GND	53	GND terminal for Analog block
A GND	54	GND connection
A VDD	55	5V power supply
NC	56	
SDA1	57	IIC bus serial data input/output
SCL1	58	IIC bus serial clock input
NC	59	
VT	60	VT output
SCL2	61	IIC bus serial clock input
SYNC	62	Horizontal sync signal input
REMOTE	63	Remote controller signal input
POWER	64	Power control (On=Hi. Off=L)

### 3.2 N001\N002 ST4053      Function: I<sup>2</sup>C bus control , Audio/Video switching IC

Name	Pin	Function
RinV2	1	This pin is for input a right audio signal from an external source(V2 channel)
RinV1	2	This pin is for input a right audio signal from an external source(V1 channel)
VinV2	3	This pin is for input a composite video signal from an external source(V2 channel)
Vout	4	This pin is for output main channel composite video signal.
VinV1	5	This pin is for input a composite video signal from an external source(V1 channel)
BAND1	6	This pin is for output band1 to control tuner.
GND	7	This is the GND pin.
GND	8	This is the GND pin.
BAND2	9	This pin is for output band2 to control tuner.
BAND2	10	This pin is for output band2 to control tuner.
BAND2	11	This pin is for output band2 to control tuner.
LinV1	12	This pin is for input a left audio signal from an external source(V1 channel)
LinV2	13	This pin is for input a left audio signal from an external source(V2 channel)
Lout TV	14	This pin is for output left audio signal.
Rout TV	15	This pin is for output right audio signal.
Vcc	16	This is the power supply pin. Apply 9V to this pin.

### 3.3 N301 LA78040 Function: V-scan output

PIN	FUNCTION
1	Vertical feedback
2	Vertical working power supply
3	Pump power supply
4	Ground
5	Vertical output
6	Vertical protection
7	Vertical drive signal input

### 3.4 N601 AN7522 Function: Audio power amplifier

Name	Pin	Function
Vcc	1	Sound working voltage (+12V)
L Out	2, 4	Sound signal output
Gnd	3	Ground
Mute	5	Standby
L In	6	Audio signal L input
Gnd	7	Ground
R In	8	Audio signal R input
Volume	9	Sound volume DC level 1 control
R Out	10,12	Sound signal output
Gnd	11	Ground

## (4) I<sup>2</sup>C Bus Control

### 4.1 Menu Entry

Press “D” button on the factory remote control to enter the “D” mode, the letter “D” will be displayed at the upper right coner and the adjusting items will be displayed at the upper left conrer. Press the channel +/- to select the preferred item; press the volume +/- to adjust the value of each item.

### 4.2 Item introduction

# TMPA8823/5VA4 BUS DATA

	Comment	int	Max	1	2	
RCUT	R CUTOFF	2C	FF	20		R Cut off 00:-0.65V, 80:0V, FF:0.65V
GCUT	G CUTOFF	20	FF	20		G Cut off 00:-0.65V, 80:0V, FF:0.65V
BCUT	B CUTOFF	47	FF	20		B Cut off 00:-0.65V, 80:0V, FF:0.65V
GDRV	G DRIVE	3B	7F	40		G Drive Gain 00:-4.5dB, 40:0dB, 7F:3.5dB
BDRV	B DRIVE	37	7F	40		B Drive Gain 00:-4.5dB, 40:0dB, 7F:3.5dB
CNTX	SUB CONTRAST	7F	7F	7F		Unicolor 00:-20dB, 40:-5dB, 7F:0dB
BRTC	SUB BRIGHT CEN	51	7F	50		Brightness 00:1.5V(pedestal level), 40:2.5V
COLC		2C	7F	40		Color 00:color mute, 01:-22dB or less, 7F:5.7dB
TNTC	SUB TINT CEN	40	7F	40		Tint: 00:-35°, 40:0°, 7F:35°
COLP	PAL SUB COLOR	00	7F	00		

COLS	SECAM SUB COLOR	32	7F	40	
SCOL	SUB COLOR(for	07	07	07	UV converter. For Y Cr Cb input
SCNT	SUB CONTRAST	09	0F	0A	Sub-Contrast 0: -4.3dB, 8:0dB, F:3.8dB
CNTC	SUB CONTRAST CEN	3F	7F	48	
CNTN	SUB CONTRAST MIN	08	7F	08	
BRTX	BRIGHT MAX	20	7F	20	Difference form center
BRTN	BRIGHT MIN	20	7F	30	Difference form center
COLX	COLOR MAX	35	7F	3F	Difference form center
COLN	COLOR MIN	00	7F	00	
TNTX	TINT MAX	28	7F	3F	Difference form center
TNTN		28	7F	3F	Difference form center
ST3	NTSC SHARP CEN	20	3F	28	Sharpness 00:-9dB, 20:0dB, 3F:10dB
SV3	NTSC SHARP CEN	20	3F	28	Sharpness 00:-9dB, 20:0dB, 3F:10dB
ST4	OTHER SHARP CEN	20	3F	28	Sharpness 00:-9dB, 20:0dB, 3F:10dB
SV4	OTHER SHARP CEN	20	3F	28	Sharpness 00:-9dB, 20:0dB, 3F:10dB
SVD	SHARP CENTER in	19	3F	28	Sharpness 00:-9dB, 20:0dB, 3F:10dB
ASSH	Asymmetry-sharpness	09	07	04	Asymmetric sharpness 0:0dB, 4:4.5dB, 7:8.5dB
SHPX	SHARP MAX	1A	3F	3F	Difference form center
SHPN	SHARP MIN	1A		12	Difference form center
TXCX	UV COLOR MAX.	1F	1F	1F	UV SUB COLOR For YcrCb input
RGCN	UV COLOR MIN.	16	1F	1F	UV SUB COLOR For YcrCb input
ABL	ABL data	27	<b>FF</b>	35	Bit7: Nouse
					Bit6: Nouse
					Bit5: RGB OSD ABL 0:ABL active for OSD
					Bit4: YPL 0:Y peak limiter on.105IRE, 1: Y peak
					Bit3.2:ABL Start Point 00:0V 01:-0.15V 10:-
Bit1.0:ABL Gain 00:-0.17V 01:-0.35V 10:-					
DCBS	A part of video data	22	FF	24	Bit7:Blank SW 0:H.V blanking on, 1:H.V blanking
					Bit6:No use
					Bit5.4:OSD Level 00:50IRE, 01:60IRE, 10:70IRE,
					Bit3.2:Y Y point,-3dB 00:off, 01:90IRE, 10:82IRE,
Bit1.0:No use					
CLTM	The data when TV mode	04	FF	28	The data when TV mode
					Bit7: F-ID 0:Normal, 1:Always killer off.i.e.
					Bit6: P/N ID Sens 0:NTSC killer sensitivity.1.5mVp-
					Bit5:color gamma off 0:off, 1:on
					Bit4.3:NTSC matrix 00:NTSC1(93 ° ),
					10/11:DVD for U/V inputs
					Bit2.0:Y D.L. 000:-40ns 001:0ns 010:+40ns
100:+120ns 101:+160ns 110:+200ns					
CLVO	The data when AV mode	43	FF	2F	The data when AV mode
					Bit7: F-ID 0:Normal, 1:Always killer off.i.e.
					Bit6: P/N ID Sens 0:NTSC killer sensitivity.1.5mVp-
					Bit5:color gamma off 0:off, 1:on
					Bit4.3: NTSC matrix 00:NTSC1(93 ° ),
					10/11:DVD for U/V inputs
					Bit2.0:Y D.L. 000:-40ns 001:0ns 010:+40ns
100:+120ns 101:+160ns 110:+200ns					
CLVD	The data when DVD	40	FF	40	
DEF		01	01	01	V AGC reference, depends on 0:YC Vcc,

		03	3F	00		AKB svstem mode(No use)
RSNS	R SENSE	28	3F	00		
GSNS	G SENSE	30	3F	00		
BSNS	B SENSE	2D	3F	00		
HPOS	60Hz Horizontal	17	1F	10		00:-3us, 10:0, 1F:3us
VP50		00	07	04		
HIT		1E	3F	26		00:-47%, 20:0%, 3F:49%
HPS	50Hz Horizontal	00		00		
VP60	60Hz Vertical phase	02	7	02		0:0H, 7:7H
HITS	50Hz Vertical size	00		00		
VLIN	60Hz Vertical linearity	0A	F	0C		0:-13%, 8:0%, F:16%
VSC	Vertical S correction	06	F	08		0:-18%, 8:0%, F:11%
VLIS	50Hz Vertical linearity	00		00		
VSS	Shift data of	00		00		
BRTS	SUB BRIGHT	00	3F	00		
RAGC	RF AGC	3C	3F	28		00:IF mute, 01:67dBu, 3F:107dBu
HAFC	HAFC GAIN	09	0F	09		<b>Bit7.6.5.4:Noise</b> Bit3.2:AFC gain for AV Bit1.0: AFC gain for TV
AGCC	AGCC(Noise))	1C	F2	1C		
FLG0		52	FF	52		Bit7:VCO readjust when position select 0:enable. Bit6.5.4.3:Noise Bit2:Buzz reducer 0:on, 1:off Bit1:AFT Window SW 0:wide(-/+250kHz). Bit0:Over Mod SW: 0:Normal, 1:PIF over
FLG1		04	1F	05		Bit7.6.5:Noise Bit4:SIF F0 Shift <b>Bit3:Noise</b> Bit2:Mix gain: 0:SIF 1MHz convert gain. Low gain. Bit1:Noise Bit0:CW SW 0:off, 1:on.CW output form "TV
REFP	AKB REF pulse	04	07	00		Noise
STBY		00	0F	00		Bit7.6.5.4:Noise <b>Bit3.2:VCD Standby 11: VCD Standby,</b> <b>Bit1.0:IF Standby 11: IF Standby, other:</b>
SVM	VSM data	10	1F	06		Bit 7-4:Noise Bit3.2: VSM delay 00:off, 01:-100ns, 10:-60ns. Bit1.0: VSM Gain 00:-6dB, 01:0dB, 10:6dB.
BLK		00	0F	00		Bit7.6.5.4:Noise <b>Bit3.2: V BLK start 00:263H, 01:254H.</b> <b>Bit1.0: V BLK stop 00:22H, 01:30H.</b>
VCEN	V centering	00	3F	10		00:-32%, 20:0%, 3F:30%
MOD	MODE	03	0F	03		<b>Bit7.6.5.4.3: Noise</b> Bit2:CO MAX 0:Cutoff range:-0.65 to +0.65 1:-0.65 Bit1.0: AKB cutoff sensitivty
UCOM	Chroma APC Setting	00	FF	60		<b>Bit7.6.5: Chroma APC setting, 011:normal</b> Bit4.3.2: Noise Bit1.0: Internal ADC, 00:GND, 01:R output, 10:B output, 11:Monitor RF
MODE3		80	FF	80		

	<b>setting</b>					Bit7,6: No use
						Bit5: Video mute type 0:R/G/B mute, 1:Y mute
						Bit4,3,2,1,0: Mute time (×8ms)
NOIS	HAFC control	01	07	01		Bit7,6,5,4,3: No use
						Bit2: AFC fix
						Bit1,0: Noise threshold
SYCT		08	FF	08		Noise
PYNX	H.SYNC MAX in	28		28		
PYNN	H.SYNC MIN in	18	3F	18		
PYXS	H.SYNC MAX in	22	3F	22		
PYNS	H.SYNC MIN in search	1E	3F	1E		
ONTM		00	FF	00		Video mute time setting when Power On(×16ms)
NSHP		1A	3F	10		Sharpness data offset when Noise Reduction is on.
V01A	VOLUME 1%	04	3F	09		Volume output data when volume=1
V25A	VOLUME 25%	3D	7F	24		Volume output data when volume=25
V50A	VOLUME 50%	57	7F	40		Volume output data when volume=50
V100A	VOLUME 100%	72	7F	72		Volume output data when volume=100
WCTL	APRO mode data	01	7F	41		Bit7: Noise
						Bit6: bass boost SW 0:off, 1:on
						Bit5: input attenuator 0:0dB, 1:-5dB
						Bit4: ALS SW 0:off, 1:on
						Bit3,2: ALS start point 00:220mv, 01:380mv.
						Bit1,0: woofer fc 00:100Hz, 01:125Hz, 10:170Hz.
SUR1	Surround data (mono)	07	1F	06		<b>Bit7,6,5: No use</b>
						Bit4,3: Input matrix 00:normal, 01:R ch, 10:L ch.
						Bit2,1,0: Surround level: 000:off, 001-111:surround
SUR2	Surround data (stereo1)	07	0F	0C		<b>Bit7,6,5,4: Noise</b>
						Bit3: Surround mode1: 0:φ 1:4φ
						Bit2,1,0: Surround level: 000:off, 001-111:surround
SUR3	Surround data (stereo2)	0F	0F	0F		<b>Bit7,6,5,4: Noise</b>
						Bit3: Surround mode1: 0:φ 1:4φ
						Bit2,1,0: Surround level: 000:off, 001-111:surround
BASC	BASS Center	40	72	40		User Bass Level
BASX	BASS MAX	72	72	72		User Bass Level
TREC	TREBLE Center	40	72	40		User Treble Level
BALC	BALANCE Center	3F	72	40		User Balance Level
WOFC	WOOFER Center	39	7F	40		User Woffer Level
BAS1	BASS data in "Music"	68		CB		Bit0-6: Bass level, bit7:Surround select.0
BAS2	BASS data in "News"	40	FF	3C		Bit0-6: Bass level, bit7:Surround select.0
BAS3	BASS data in "Theater"	4A	FF	CB		Bit0-6: Bass level, bit7:Surround select.0
TRE1	TREBLE data in	68	FF	55		Bit0-6: Treble level, bit7:Surround select.1
TRE2	TREBLE data in	40	FF	37		Bit0-6: Treble level, bit7:Surround select.1
TRE3	TREBLE data in	54	FF	A8		Bit0-6: Treble level, bit7:Surround select.1
WFL1	Woofer data in "Music"	F2	FF	CB		Bit0-6: Woofer level, bit7:Woofer On/Off 1:On
WFL2	Woofer data in "News"	31	FF	99		Bit0-6: Woofer level, bit7:Woofer On/Off 1:On
WFL3	Woofer data in	D9	FF	E4		Bit0-6: Woofer level, bit7:Woofer On/Off 1:On
WON1	Woofer output level	0A	FF	05		For the calculation of the Woofer output value.
WON2	Woofer output level	09	FF	09		For the calculation of the Woofer output value.
WOFF	Woofer output level	00	FF	00		A Woofer output level in Woofer off.
AUCON1	Stereo/SAP noise	88	FF	88		Bit0-3: ST0-ST3



	threshold					Bit4-7: SP0-SP3
AUCON2	Level adjust setting	08	FF	03		Bit0-3: L0-L3
						Bit4-6: Nouse
						Bit7: STS
AUALI1	For wideband expander	10	FF	00		Bit0-4: A10-A14
						Bit5-7: Nouse
AUALI2	For spectral expander	10	FF	00		Bit0-4: A20-A24
						Bit5-7: Nouse
AUTIM	Timing current alienment data	03	FF	03		Bit0-2: TC0-TC2
						Bit3-7: Nouse
AUSTP	Audio step	01	0F	01		Nouse
VPCT	X-ray protection	02	FF	02		
TUNR		01	02	00		0:Toshbia, 1:ACOM, 2:ALPS
CCDOSD		2E	7F	22		OSD horizontal position for CCD
CCDOSDE		59	FF	59		OSD frequency for CCD
OSDF		51	69	53		OSD frequency
OSD		10	7F	22		<b>OSD horizontal position</b>
PDOPT0	<b>PANDA OPTION0</b>	03	<b>FF</b>			<b>PANDA OPTION0</b>
						Bit7: Nouse
						Bit6: Fip snd menu 0:off, 1:on 关闭立体声菜单
						Bit5: Fmulti colorsys 0:off, 1:on 南美三制式
						Bit4: Fip vchip 0:off, 1:on
						Bit3: Flang portuguese: 0:off, 1:on
						Bit2: Flang Spanish 0:off, 1:on
						Bit1: Fip close screen 0:off, 1:on
						Bit0: Fip open screen 0:off, 1:on
	Waiting time	2F	FF	58		<b>Waiting time before curtain open</b>
Curce	<b>Curtain center</b>	A5	FF	A5		
curste	Curtain open/close step	02	08	02		
PWR	Self check data	00	FF	00		
BUS	Self check data	00	03	00		
MEM	Self check data	00	FF	00		
OPT	Optional setting	1F	FF			Bit7: Fsvnc det blue back (set 1)
						Bit6: Nouse
						Bit5: Fsvnc det (set 0)
						Bit4: When B.B.OSD frequence 0:50Hz, 1:60Hz
						Bit3: Ftb1231n audio gain(au gain VCD 14h)
						Bit2: Fymute use
						Bit1: F bb exmute
						Bit0: F bb mute
OPTM1	Optional setting1	22	FF			Bit7: Fip stereo (select 1343) 1:select 0:unselect 立体
						Bit6: set 0
						Bit5: Fdvd audio av2
						Bit4: no use
						Bit3: set 0
						Bit2: Fip pwm balance
						Bit1: Fip pwm8 volume
						Bit0: Fsel video2
OPTM2	Optional setting	02	FF			Bit7: Fip sanvokey
						Bit6: Fip swoofer

						Bit5 :set 0
						Bit4: Fselect tda9850 打开
						Bit3: Fslice level.
						Bit2: F lan s out (shop out spanish)
						Bit1: F lan p out (shop out portuguese)
						Bit0: Fmono avout 0:mono 1: stereo
OPTM3	Option setting	01	FF			

**Note: the bold date cannot be changed**

### (5) IC voltage

#### N501 TMPA8823

PIN	1	2	3	4	5	6	7	8	9	10	11	12	13
Voltage	/	/	/	0	5	2.4	2.3	0	5	0	0	1.1	1.9
PIN	14	15	16	17	18	19	20	21	22	23	24	25	26
Voltage	6.6	4.2	4.7	9	/	2.5	2.5	2.5	0	2.5	2.5	3.3	/
PIN	27	28	29	30	31	32	33	34	35	36	37	38	39
Voltage	4.9	4.6	9	5.1	1.8	4.1	3	2.3	2.4	5	2.2	4.4	4.2
PIN	40	41	42	43	44	45	46	47	48	49	50	51	52
Voltage	0	0	0	4.5	2.7	2.7	1.9	2.6	0	9	2.5	2.5	2.5
PIN	53	54	55	56	57	58	59	60	61	62	63	64	
Voltage	0	0	5	/	4.8	4.8	/	/	/	4.4	2.5	/	

#### N001\N002 ST4053

PIN	1	2	3	4	5	6	7	8	9	10	11	12	13
Voltage	4.4	4.4	0	0	0	0	0	0	0	0	0	3.3	3.3
PIN	14	15	16										
Voltage	3.1	4.4	9										

#### N301 LA78040

PIN	1	2	3	4	5	6	7
Voltage	2.9	23.6	2.1	0	10.7	23.8	2.9

#### N601 AN7522

PIN	1	2	3	4	5	6	7	8	9	10	11	12
Voltage	12	5.4	0	5.4	3.7	1.46	0	1.46	3.5	5.4	0	5.4

**(6). Trouble shorting  
T804**

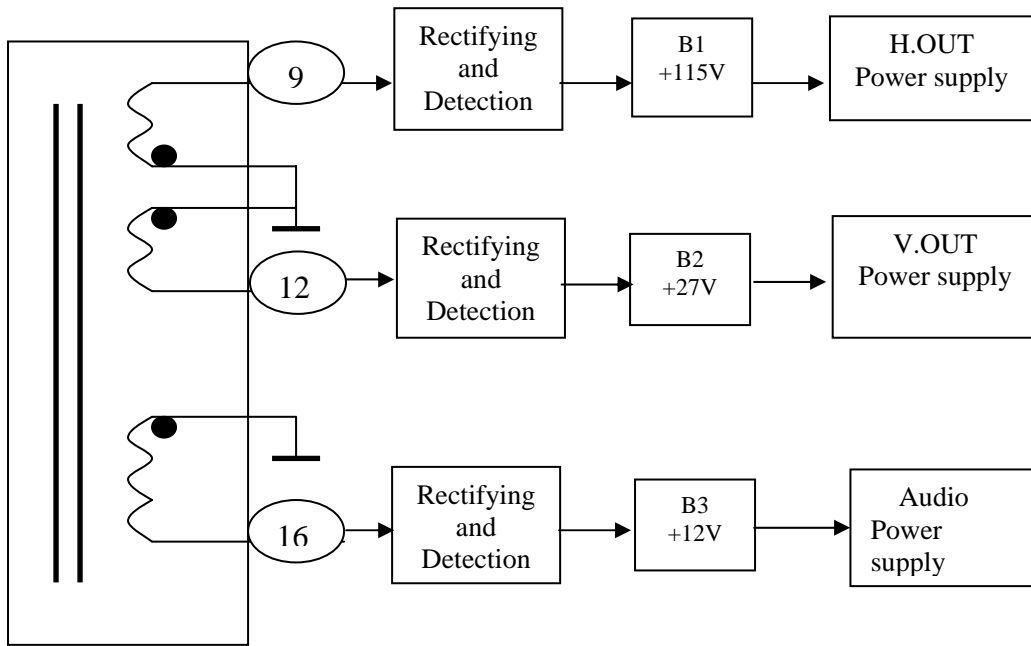

Power supply outline

**6.1 No grating, no picture, no sound**

General, these failures are produced by power sources, because of which refer to a wider area, so that can be divided them two conditions to explain: no B1 115 V and existing B1 115V.

(1) No B1 (115 V) voltage (voltage of network 220 V ac)

These failures may be caused by power supply switch.

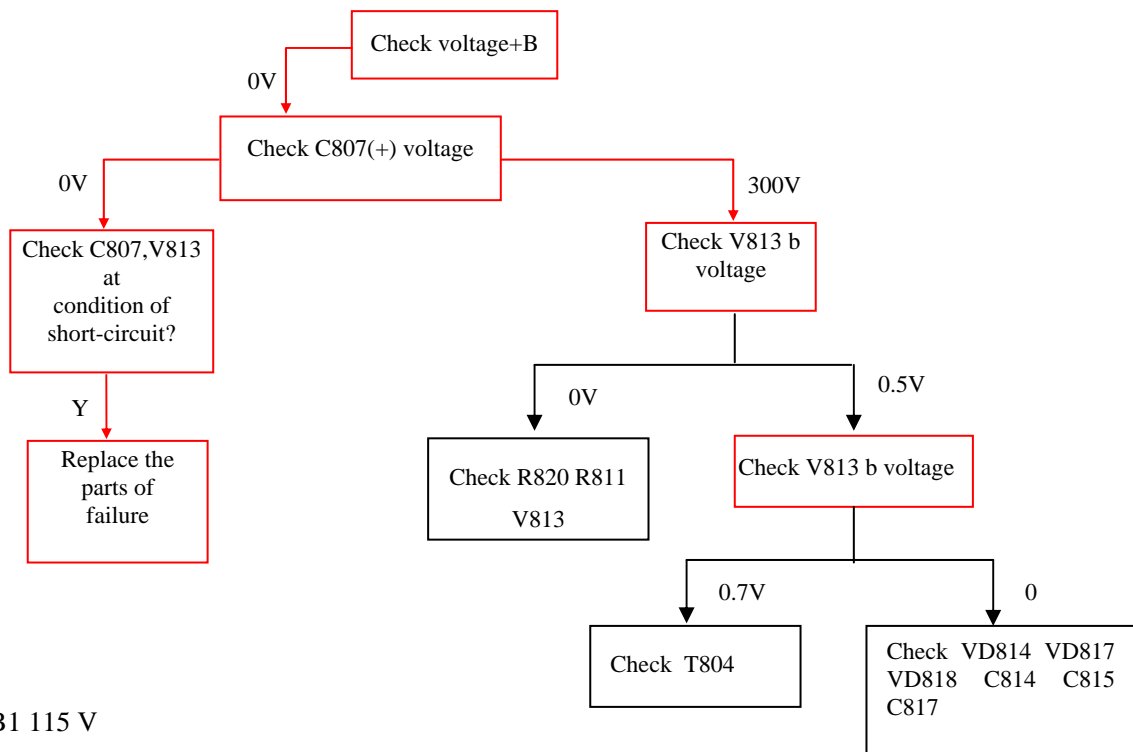

(2) Existing B1 115 V

These failures may be caused by abnormal operation of horizontal scan, to confirm which can observe the filament of

tube whether bright on. If determined horizontal scan in abnormal operation, look for the failure start from the horizontal drive stage. Search upward to TMPA8821 with method of checking DC voltage and waveform according to sequence: PIN13/H.OUT port→ PIN17 power supply→ N802/9V output.

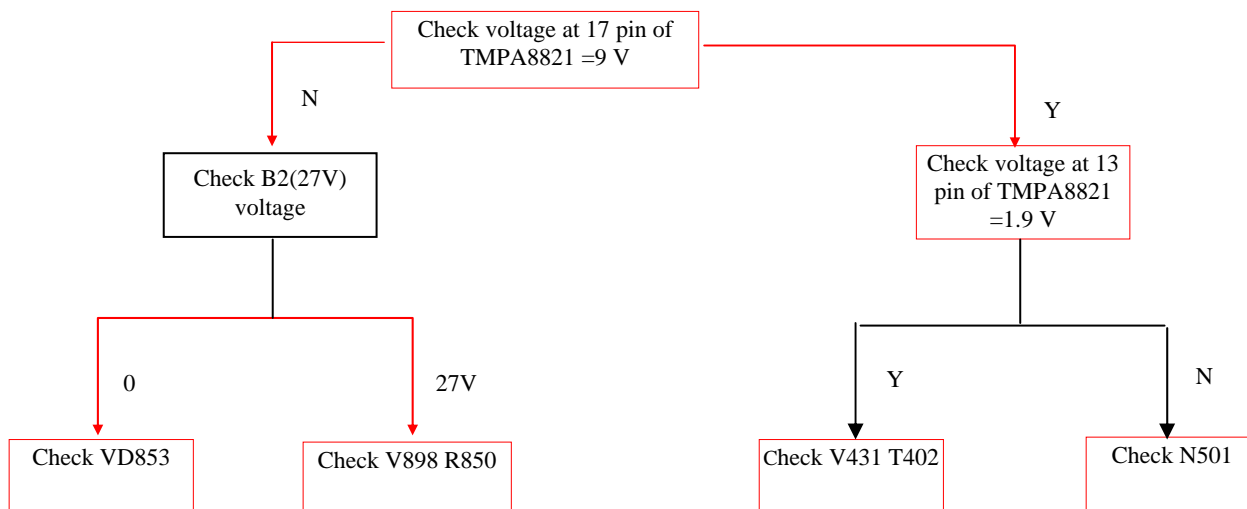

## 6.2 Existing grating and no picture

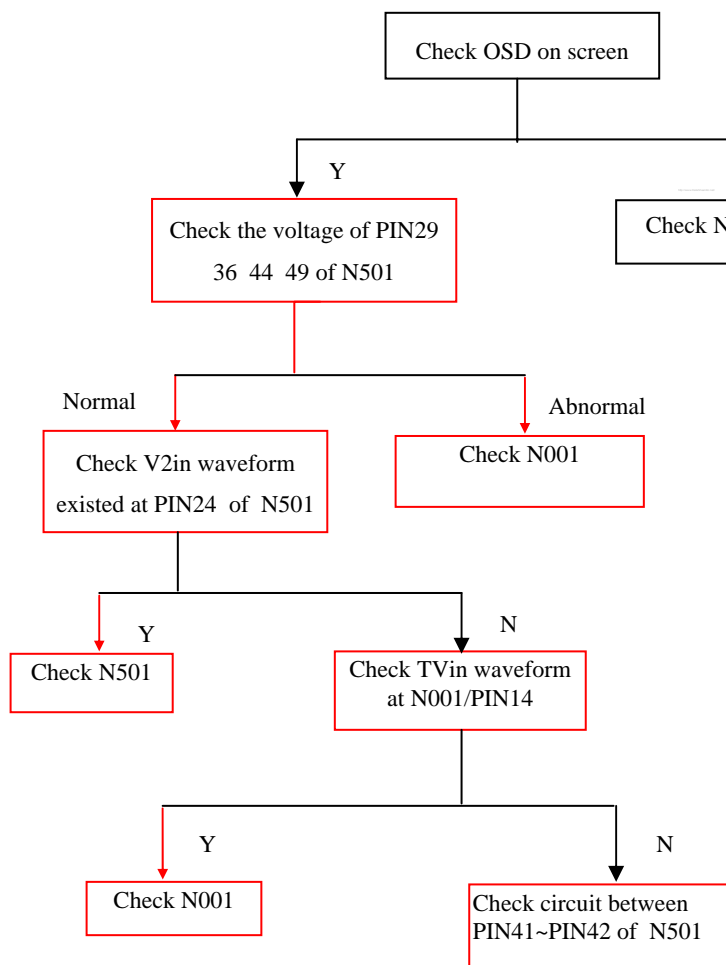

\* : Whenever open or interconnect on the bus from CPU to E<sup>2</sup>PROM and main chip, no picture can occur.

### 6.3 Existing grating and picture, no sound

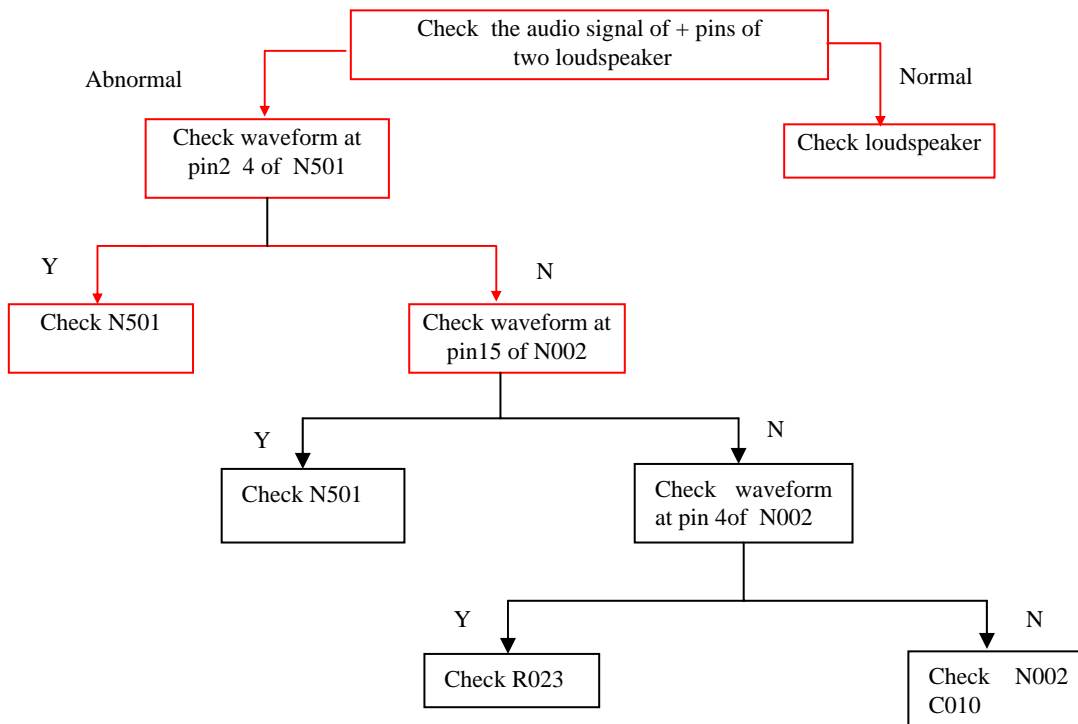

### 6.4 Cannot save channels

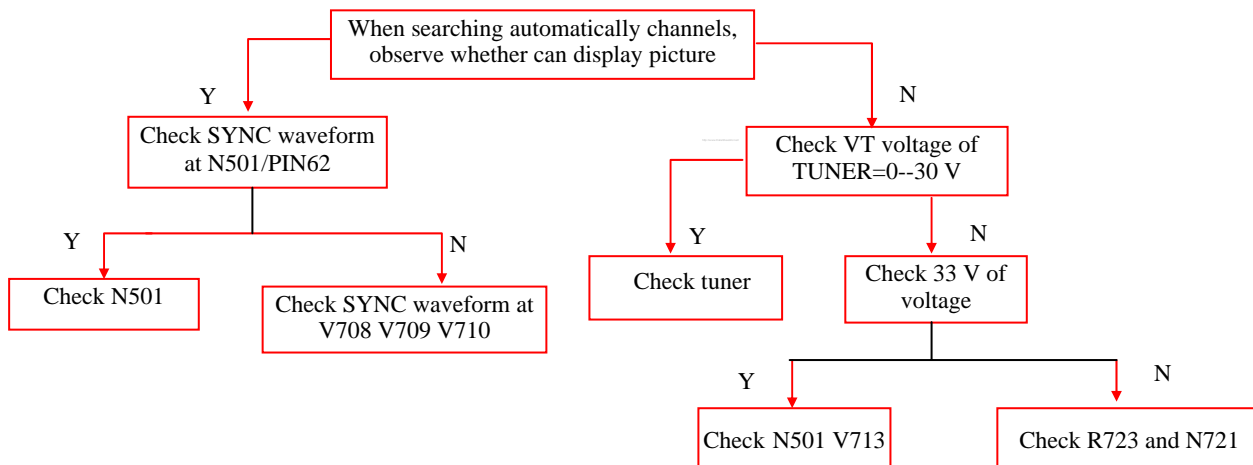

### 6.5 CPU non-operating

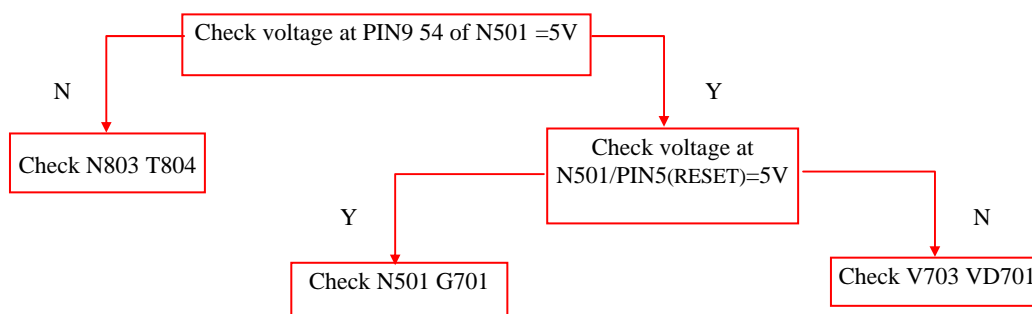



N° Boletín	2166	Fecha	21/06/2006
Identificación del Producto	TELEVISOR COLOR		
Modelos	TVS-1430 MA TVS-2142MA TVS-2152PF	Procedencia / Marca	SANYO
<b>Falla Reportada / Motivo :</b>			
METODO PARA ENTRAR AL MODO DE SERVICIO DEL TELEVISOR.			
<b>Solución aplicada :</b>			
<p>La "D" en el Manual de Servicios significa Modo "D". Los modos de fábrica son el Modo "S" y el Modo "D". En el modo "S" sólo se pueden ajustar algunos parámetros; mientras que en el modo "D" se pueden ajustar todos los parámetros. Para los Chasis TMPA8823 (TV's de 14" hasta 21") y TMPA8859 (TV's de 25" hasta 34"), se puede acceder al modo "S" utilizando el control remoto del usuario siguiendo los siguientes pasos:</p> <p>Presione el botón VOL - en el panel de la TV hasta 0 (no suelte el botón VOL -), luego presione el botón DISPLAY en el control remoto para entrar al modo S.</p> <p>Si se quiere acceder al modo "D", para el Chasis TMPA8823 (TV's de 14" hasta 21"), siga los siguientes pasos utilizando el control remoto:</p> <p>Primero siga los pasos para entrar al modo "S".</p> <p>Presione el botón DISPLAY en el Control Remoto.</p> <p>Presione el botón VOL - en el panel de la TV hasta 0 (no suelte el botón VOL -), luego presione el botón DISPLAY en el control remoto para entrar al modo D.</p>			
Técnico emisor	Roberto Quiñones M.	Uso interno	
Revisado por	J C. Zambrano.	V°B°	J.C.Z.B.
<b>INCLUYA ESTA INFORMACIÓN EN SU MANUAL DE SERVICIO</b>			

# TMPA8821 AV STEREO DVD 2 IN 1

