

Transcend 44-Pin IDE Flash Module TS32M ~ 64MDOM44H

Description

With an IDE interface and strong data retention ability, 44-Pin IDE Flash Modules are ideal for use in the harsh environments where Industrial PCs, Set-Top Boxes, etc. are used.

Placement

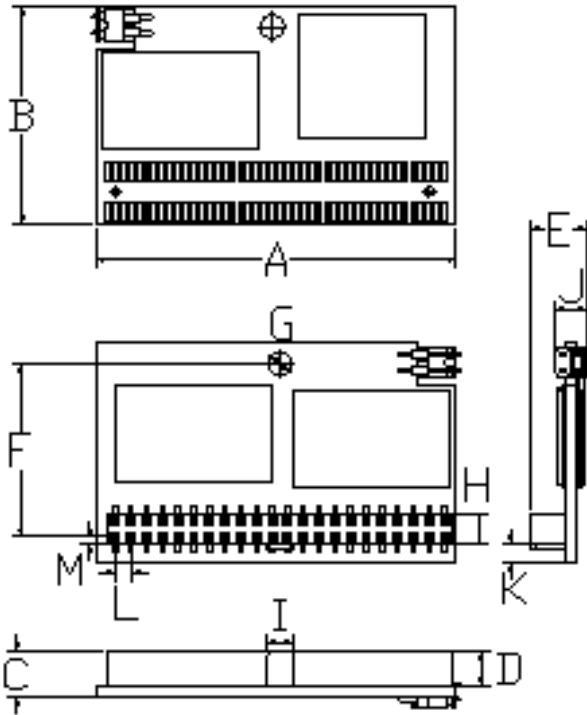

Features

- RoHS compliant products
- Storage Capacity: 32MB ~ 64MB
- Operating Voltage: 3.3V \pm 5% or 5V \pm 10%
- Operating Temperature: 0°C ~ 70°C
- Endurance: 1,000,000 Program/Erase cycles
- Durability of Connector: 5,000 times
- Fully compatible with devices and OS that support the IDE standard (pitch = 2.00mm)
- Built-in ECC function assures high reliability of data transfer
- Auto Sleep and Power-Down modes supported
- Supports up to PIO mode 2

Dimensions

Side	Millimeters	Inches
A	46.00 \pm 0.40	1.81 \pm 0.02
B	28.00 \pm 0.20	1.10 \pm 0.01
C	5.77 \pm 0.10	0.23 \pm 0.005
D	4.50 \pm 0.10	0.18 \pm 0.005
E	7.12 \pm 0.10	0.28 \pm 0.005
F	22.12 \pm 0.20	0.87 \pm 0.01
G (Diameter)	3.30 \pm 0.10	0.13 \pm 0.005
H	4.00 \pm 0.10	0.16 \pm 0.005
I	3.50 \pm 0.10	0.14 \pm 0.005
J	4.00 \pm 0.10	0.16 \pm 0.005
K	2.19 \pm 0.05	0.08 \pm 0.003
L	2.00 \pm 0.05	0.08 \pm 0.003
M	1.00 \pm 0.05	0.04 \pm 0.003

Transcend 44-Pin IDE Flash Module TS32M ~ 64MDOM44H

Pin Assignments

Pin No.	Pin Name	Pin No.	Pin Name	Pin No.	Pin Name	Pin No.	Pin Name
01	RESET	11	HD3	21	NC	31	IREQ
02	GND	12	HD12	22	GND	32	IOIS16B
03	HD7	13	HD2	23	IOWB	33	HA1
04	HD8	14	HD13	24	GND	34	PDIAGB
05	HD6	15	HD1	25	IORB	35	HA0
06	HD9	16	HD14	26	GND	36	HA2
07	HD5	17	HD0	27	NC	37	CE1B
08	HD10	18	HD15	28	NC	38	CE2B
09	HD4	19	GND	29	NC	39	DASPB
10	HD11	20	VCC	30	GND	40	GND

Pin Definition

Symbol	Function
HD0 ~ HD15	Data Bus (Bi-directional)
HA0 ~ HA2	Address Bus (Input)
RESET	Device Reset (Input)
IORB	Device I/O Read (Input)
IOWB	Device I/O Write (Input)
IOIS16B	Transfer Type 8/16 bit (Output)
CE1B, CE2B	Chip Select (Input)
PDIAGB	Pass Diagnostic (Bi-directional)
DASPB	Disk Active/Slave Present (Bi-directional)
IREQ	Interrupt Request (Output)
NC	No Connection
GND	Ground
VCC	Vcc Power Input

Pin Layout

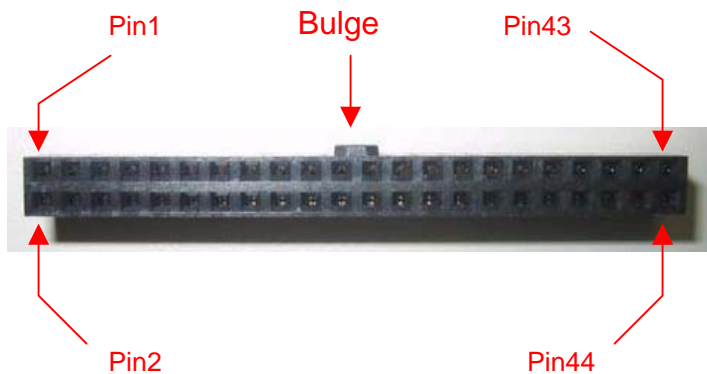

Transcend 44-Pin IDE Flash Module TS32M ~ 64MDOM44H

Block Diagram

With 1 pcs of Flash Memory:

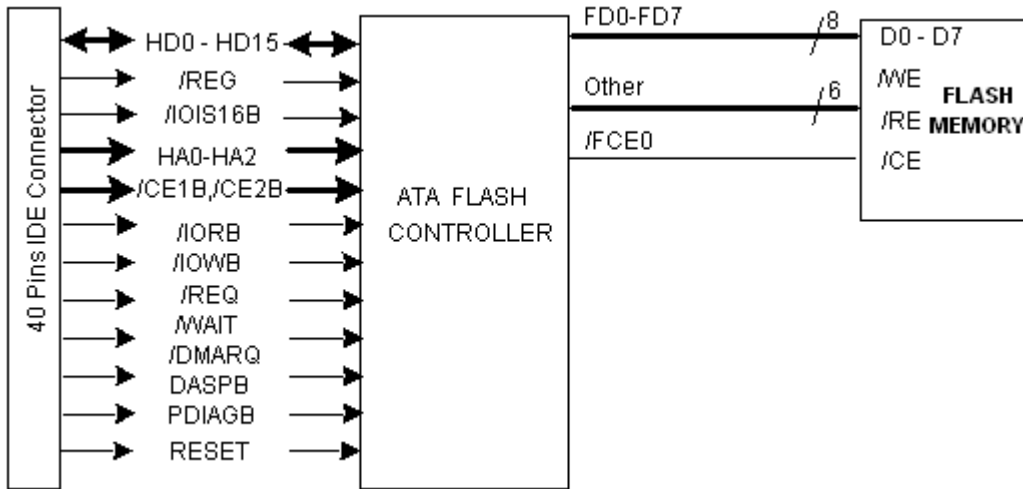

With 2 pcs of Flash Memory:

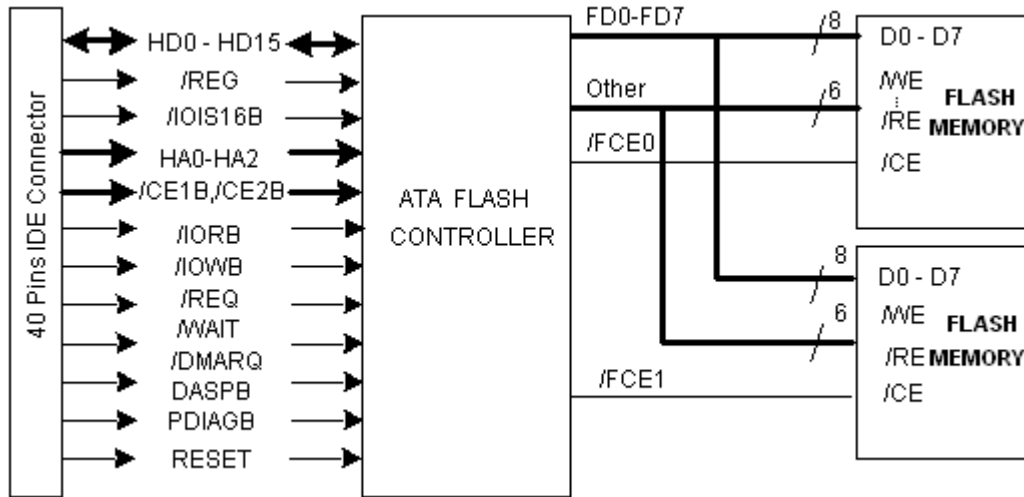

Transcend 44-Pin IDE Flash Module

TS32M ~ 64MDOM44H

Absolute Maximum Ratings

Symbol	Parameter	Rating	Units
VDD	Power supply	-0.3 to +6.7	V
VIN	Input voltage	-0.3 to $V_{DD} + 0.3$	V
VOUT	Output voltage	-0.3 to $V_{DD} + 0.3$	V
TSTG	Storage temperature	-40 to 125	°C

Recommended Operating Conditions

Symbol	Parameter	Min	Max	Units
VDD	Power supply	3.0	5.5	V
VIN	Input voltage	0	VDD	V
TOPR	Operating temperature	0	70	°C

DC Characteristics ($T_a=0\text{ }^{\circ}\text{C}$ to $+70\text{ }^{\circ}\text{C}$, $V_{cc} = 3.3\text{V} \pm 10\%$)

Parameter	Symbol	Conditions	Min	Typ	Max	Unit
Input Voltage	VIH	--	$0.7 \times V_{cc}$	--	$V_{cc} + 0.3$	V
	VIL	--	-0.3	--	$0.2 \times V_{cc}$	V
Output Voltage IOL = 3mA	VOH	IOL = -3mA	$V_{cc} - 0.4$	--	--	V
	VOL	IOL = 3mA	--	--	0.4	V
Input leakage current	ILK	VIH = VDD / VIL = GND	-1	--	1	uA
Sleep current	ISP	Control signal = $V_{cc} - 0.2$	--	80	--	uA
Sector read current	ISR (DC)	Control signal = $V_{cc} - 0.2$	--	20	--	mA
	ISR (Peak)		--	40	--	mA
Sector write current	ISW (DC)	Control signal = $V_{cc} - 0.2$	--	25	--	mA
	ISW (Peak)		--	50	--	mA

Transcend 44-Pin IDE Flash Module TS32M ~ 64MDOM44H

True IDE Mode Access Read AC Characteristics

Parameter	Symbol	Min	Typ	Max	Unit
Data delay after IORD	td(IORD)	—	—	55	ns
Data hold following IORD	th(IORD)	0	—	—	ns
IORD width time	tw(IORD)	70	—	—	ns
Address setup before IORD	tsuA(IORD)	25	—	—	ns
Address hold following IORD	thA(IORD)	10	—	—	ns
CE setup before IORD	tsuCE(IORD)	5	—	—	ns
CE hold following IORD	thCE(IORD)	10	—	—	ns
IOIS16 delay falling from address	tdfIOIS16(ADR)	—	—	35	ns
IOIS16 delay rising from address	tsfIOIS16(ADR)	—	—	35	ns

True IDE Mode Access Read Timing

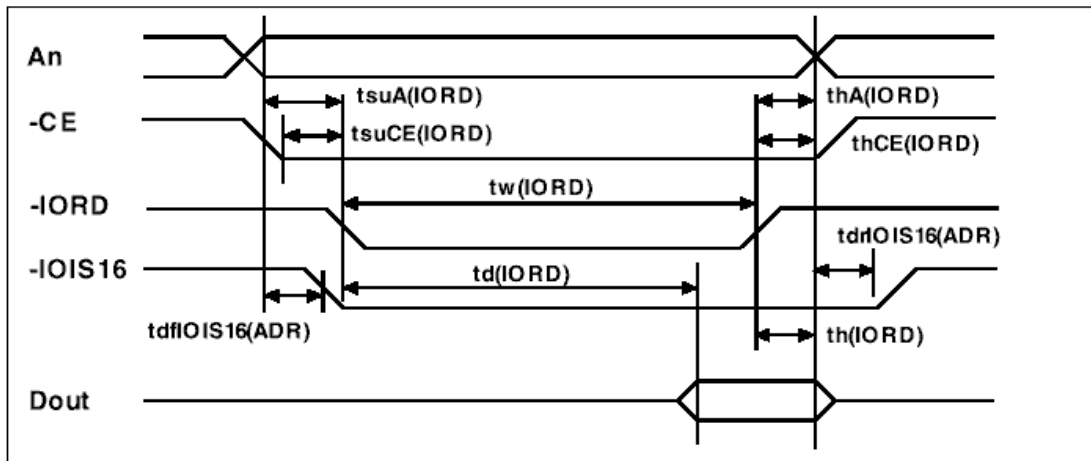

Transcend 44-Pin IDE Flash Module TS32M ~ 64MDOM44H

True IDE Mode Access Write AC Characteristics

Parameter	Symbol	Min	Typ	Max	Unit
Data setup before IOWR	tsu(IOWR)	20	—	—	ns
Data hold following IOWR	th(IOWR)	10	—	—	ns
IOWR width time	tw(IOWR)	70	—	—	ns
Address setup before IOWR	tsuA(IOWR)	25	—	—	ns
Address hold following IOWR	thA(IOWR)	10	—	—	ns
CE setup before IOWR	tsuCE(IOWR)	5	—	—	ns
CE hold following IOWR	thCE(IOWR)	10	—	—	ns
IOIS16 delay falling from address	tdfIOIS16(ADR)	—	—	35	ns
IOIS16 delay rising from address	tsfIOIS16(ADR)	—	—	35	ns

True IDE Mode Access Write Timing

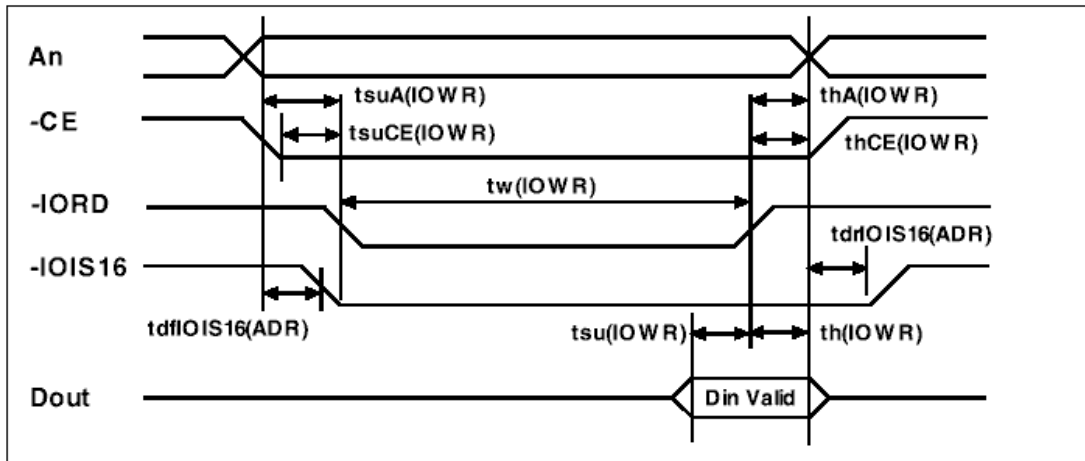

Transcend 44-Pin IDE Flash Module TS32M ~ 64MDOM44H

Ordering Information

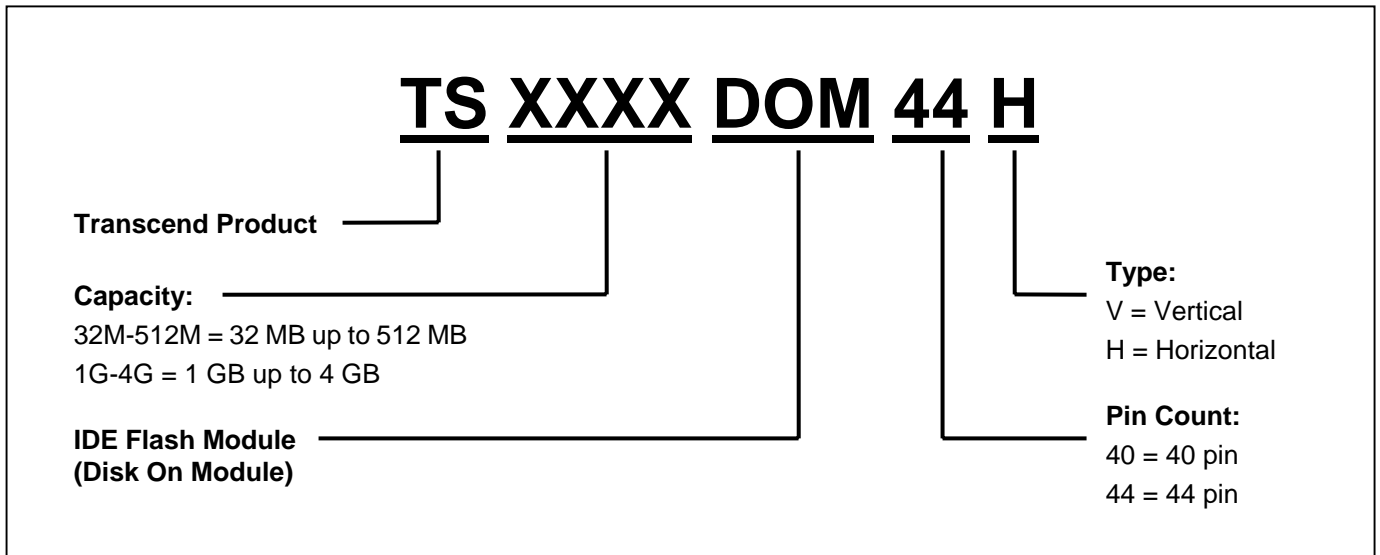

The above technical information is based on industry standard data and has been tested to be reliable. However, Transcend makes no warranty, either expressed or implied, as to its accuracy and assumes no liability in connection with the use of this product. Transcend reserves the right to make changes to the specifications at any time without prior notice.

	USA <i>Los Angeles:</i> E-mail: sales@transcendusa.com <i>Maryland:</i> E-mail: sales_md@transcendusa.com www.transcendusa.com
	CHINA E-mail: sales@transcendchina.com www.transcendchina.com
TAIWAN No.70, XingZhong Rd., NeiHu Dist., Taipei, Taiwan, R.O.C TEL +886-2-2792-8000 Fax +886-2-2793-2222 E-mail: sales@transcend.com.tw www.transcend.com.tw	GERMANY E-mail: vertrieb@transcend.de www.transcend.de
	HONG KONG E-mail: sales@transcend.com.hk www.transcendchina.com
	JAPAN E-mail: sales@transcend.co.jp www.transcend.jp
	THE NETHERLANDS E-mail: sales@transcend.nl www.transcend.nl
	United Kingdom E-mail: sales@transcend-uk.com www.transcend-uk.com