



Technical Reference Notes
ALQ25 Series
(Open Frame Single Output Quarter Brick)



***ALQ25 Single Output Open-Frame DC-DC Converter Module
Industry Standard ¼Brick: 36V-75V Input / 5V Output***

The ALQ25 series is Astec's next generation single output, high-density standard quarter brick offering. It operates from a 36V to 75V DC Bus and comes in different Isolated Logic Output voltages (ILO) well suited for DPA applications. It's designed to conservatively handle 25A of output current for 5V and at high levels of efficiency (5V @ 91%). It provides tight regulation and exhibits clean and monotonic output start up characteristics. The ALQ25's come with industry standard features such as Input UVLO, OCP, OVP, OTP, Output Trim, differential output Sense pins.



Special Features

- Industry Standard ¼ Brick Footprint
- Positive and Negative Enable Options
- Regulation to Zero Load
- High Capacitive Load Start-up
- Fixed Switching Frequency at 200kHz
- Output Trim
- Input Under-Voltage Lockout
- Low profile / open-frame

Environmental Specifications

- -40°C to 85°C Operating Temperature (200LFM)
- -40°C to 120°C Storage Temperature
- MTBF > 1 million hours

Electrical Parameters

Input

Input Range	36-75 VDC
Input Surge	100V / 100ms
Efficiency	91% (Typ)

Control

Enable (Positive and Negative Enable Options)	TTL compatible
--	----------------

Output

Load Current	5.0V @ 25A max
Line Regulation	0.2 % V_O
Load Regulation	0.4 % V_O
Ripple and Noise	150mV _{PK-PK} max for 5V

Output Voltage

Adjust Range	$\pm 10\% V_O$
Transient Response	5% V_O deviation (Typ) 50% to 75% Load Change 400msec settling time (Typ)

Remote Sense	+10% V_O
Over Current Protection	140% $I_{O,MAX}$

Safety

UL + cUL 60950, Recognized (Pending)
EN60950 through TUV-PS (Pending)



Technical Reference Notes
ALQ25 Series
(Open Frame Single Output Quarter Brick)



ALQ25 Series

THIS SPECIFICATION COVERS THE REQUIREMENTS FOR A NEW ¼-BRICK SIZE
25A SINGLE OUTPUT HIGH EFFICIENCY DC/DC CONVERTER.

MODEL NAME	V _{OUT} / I _{OUT}	Serial No. Prefix
ALQ25A48	5.0V/25A	B737
ALQ25A48N	5.0V/25A	B742
ALQ25A48-7	5.0V/25A	C511
ALQ25A48N-7	5.0V/25A	C514

OPTIONS:

Negative Enable:
Positive Enable:
5.8mm pin option

SUFFIX
"N"
No suffix
-7



Technical Reference Notes
ALQ25 Series
(Open Frame Single Output Quarter Brick)



Electrical Specifications

STANDARD TEST CONDITION on a single module unless otherwise specified.

T _A		25°C (Ambient Air)
Airflow		See derating curve
-V _{IN}	PIN 1	48V ± 2V
ENABLE	PIN 2	Dependent on model series
+V _{IN}	PIN 3	Return pin for +V _{IN}
-V _{OUT}	PIN 4	Connected to Load (return)
-Sense	PIN 5	Connected to -V _{OUT}
Trim	PIN 6	Open
+Sense	PIN 7	Connected to +V _{OUT}
+V _{out}	PIN 8	Connected to Load

ABSOLUTE MAXIMUM RATINGS

Stresses in excess of the absolute maximum ratings can cause permanent damage to the converter. Functional operation of the device is converter is not implied at these or any other conditions in excess of those given in the operational section of the specs. Exposure to absolute maximum ratings for extended period can adversely affect device reliability.

Parameter	Device	Symbol	Min	Typ	Max	Unit
Input Voltage ¹						
Continuous	All	V _{IN}	0	-	80	Vdc
Transient (100ms)	All	V _{IN,trans}	0	-	100	Vdc
Isolation Voltage						
Input to Output	All		-	-	1500	Vdc
Operating Ambient Temperature (200LFM)	All	T _A	-40	-	+85	°C
Storage Temperature	All	T _{STG}	-40	-	120	°C
Operating Humidity	All	-	-	-	85	%
Max Output Power	A (5.0V)	P _O	-	-	125	W



Technical Reference Notes ALQ25 Series (Open Frame Single Output Quarter Brick)



INPUT SPECIFICATION

Parameter	Device	Symbol	Min	Typ	Max	Unit
Operating Input Voltage	All	V_{IN}	36	48	75	V _{DC}
Input Under-Voltage Lock-out T_ON Threshold T_OFF Threshold	All		31 30	34 33	36 35	Vdc
Maximum Input Current ¹ Conditions: $V_{IN} = V_{IN,min}$ $I_O = I_{O,max}$; $T_A = 25\text{ }^\circ\text{C}$	A (5.0V)	$I_{IN,max}$	-	-	6	A
Max P _{DISS} @ $I_O = 0\text{A}$ ($V_{IN} = V_{IN,NOM}$)	A (5.0V)		-	-	7.5	W
Input Reflected Ripple Current ² Conditions: $P_O = P_{O,max}$; $T_A = 25\text{ }^\circ\text{C}$ BW: 5Hz to 20MHz	All	I_{I1}/I_{I2}	-	-	260	mA _{PK-PK}

- Note: 1. An input line fuse is recommended for use.
2. External input capacitance required. See Input Ripple Current test measurement setup on Fig 1.

OUTPUT SPECIFICATIONS

Parameter	Device	Symbol	Min	Typ	Max	Unit
Output Voltage Set point $V_{IN} = V_{IN, min}$ to $V_{IN, max}$; $I_O = I_{O,Max}$	A (5.0V)	$V_{O,SET}$	4.9	5.0	5.1	Vdc
Output Regulation Line: $V_{IN} = V_{IN, Min}$ to $V_{IN, Max}$ Load: $I_O = I_{O, Min}$ to $I_{O, Max}$ Temperature: $T_a = -40\text{ }^\circ\text{C}$ to $+85\text{ }^\circ\text{C}$	A (5.0V) A (5.0V)	- -	- -	0.1 0.2	0.2 0.4	% V _o % V _o
Ripple and Noise ³ Peak-to-Peak: (5Hz to 20MHz)	A (5V)	-			150	mVp-p
Output Current ⁴	A (5V)	I_O	0	-	25	A
External Load Capacitance	A (5V)	-	470	-	8000	μF
Output Current-limit Inception $V_{OUT} = 90\% V_{O,SET}$	A (5V)	I_O	27.5	-	35	A



Technical Reference Notes
ALQ25 Series
(Open Frame Single Output Quarter Brick)



OUTPUT SPECIFICATIONS

Parameter	Device	Symbol	Min	Typ	Max	Unit
Over Voltage Protection Range	A (5.0V)		6		7	V
Over Temperature Range (AVG PCB TEMPERATURE)	All		110	-	120	°C
Efficiency $V_{IN} = V_{IN-NOM}; I_O = I_{O,MAX}$ $T_A = 25^\circ C$	A (5.0V)	η	89	91	-	%
Turn-On Response Time $V_{IN} = V_{IN-MIN}$ to V_{IN-MAX}	All	-	-	-	20	ms
Switching Frequency	All	-	-	200	-	KHz
Dynamic Response ⁵ : $\Delta I_O / \Delta t = 0.1A / \mu S$		-	-	0.1	-	A/ μs
Load Change from $I_O = 10\%$ to 100% of $I_{O, Max}$: Peak Deviation Settling Time to $V_{O, Nom}$	5V	-	-	250	500	μs mV
Load Change from $I_O = 50\%$ to 25% of $I_{O, Max}$: Peak Deviation Settling Time to $V_{O, Nom}$	5V	-	-	400	250	μs mV
Output Overshoot at T-on / T-off Passive Resistive Full Load	All	-	-	-	5	% V_O

- Note: 3. See Figure 2 for Ripple and Noise test measurement setup.
 4. Appropriate Thermal Derating applies. See Figure 13 for the Thermal Derating Curves
 5. The Dynamic Deviation and Recovery time are defined as below

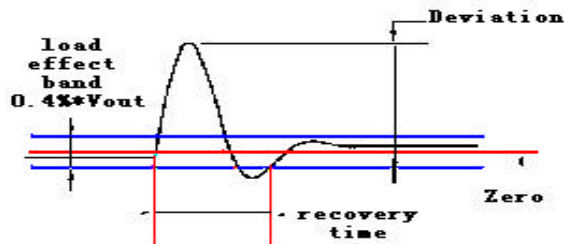



Technical Reference Notes
ALQ25 Series
(Open Frame Single Output Quarter Brick)



FEATURE SPECIFICATION

Parameter	Device	Symbol	Min	Typ	Max	Unit
Output Enable ON/OFF ¹⁰						
Negative Enable ("N" suffix)	N	-	-0.7	-	1.2	V
Enable Pin voltage for Module ON	suffix	-	3.5	-	12	V
Module OFF						
Positive Enable (No suffix)	No	-	3.5	-	12	V
Enable Pin voltage for Module ON	suffix	-	-0.7	-	1.2	V
Module OFF						
Output Voltage Remote Sensing ^{11,13}	All	-	-	-	10	% V _O
Output Voltage Trim Range ^{12,13}	All		90		110	% V _O

- Note:
10. See Basic Operation and feature section for the recommended/ appropriate Module Enable configuration.
 11. The sense pins can be used to compensate for any voltage drops (per indicated max limits) that may occur along the connection between the output pins to the load. Pin 7 (+Sense) and Pin 5 (-Sense) should be connected to Pin 8 (+Vout) and Pin 4 (Return) respectively at the point where regulation is desired.
 12. Refer to Equation (1) and (2) and Figures 3 and 4 for the Output Trim Adjust configuration.
 13. The combination of remote sense and Trim adjust cannot exceed 110% of V_{O,NOM}.

ISOLATION SPECIFICATION

Parameter	Device	Symbol	Min	Typ	Max	Unit
Isolation Capacitance	All	-	-	1000	-	pF
Isolation Resistance	All	-	10	1000	-	MΩ

SAFETY APPROVAL

The ALQ25 series have been certified through:

- UL + cUL 60950, Third Edition - Recognized
- EN 60950 through TUV-PS
- Basic Insulation

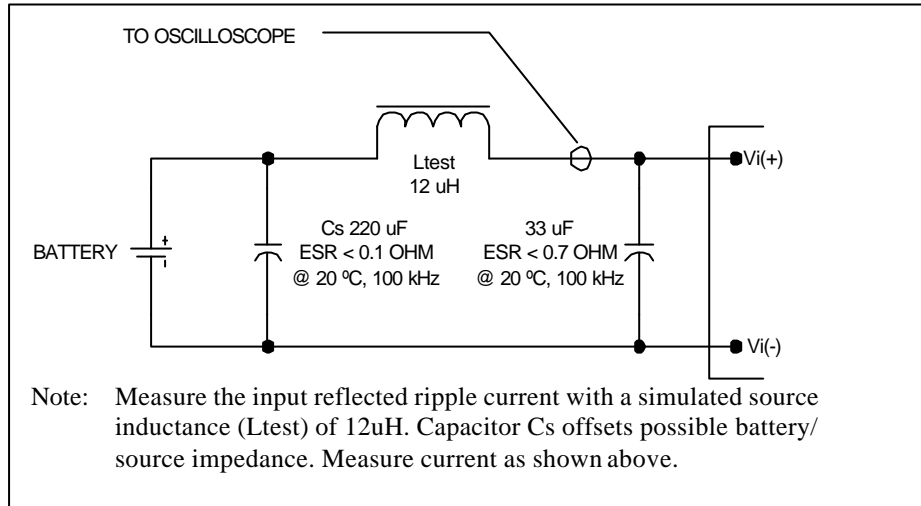

Figure 1. Input Reflected Ripple Current Measurement Setup.

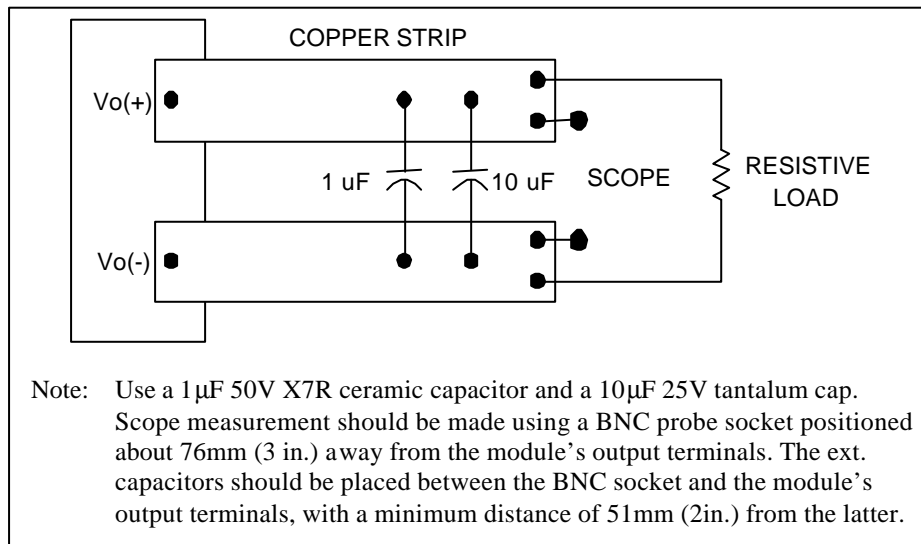

Figure 2. Peak to Peak Output Noise Measurement Setup.



Technical Reference Notes
ALQ25 Series
(Open Frame Single Output Quarter Brick)

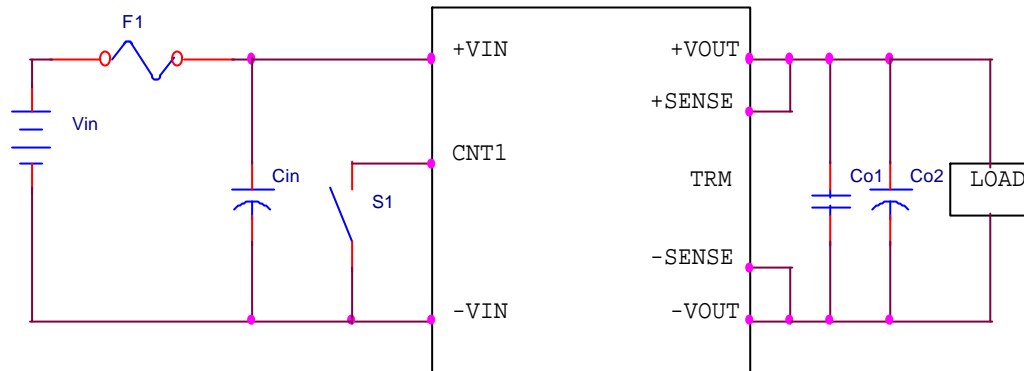

Figure 3. Setup for Parametric Test.

F1: Fuse*: Use external fuse (fast blow type **10A**) for each unit.

Cin: Recommended input capacitor 100uF/100V high frequency low ESR electrolytic type capacitor (NICHICON KME serial OR equate.)

Co1: Recommended 1uF/25V ceramic capacitor

Co2: Recommended output capacitor 1000uF/10V high frequency low ESR electrolytic type capacitor. (NICHICON LXV serial OR equate.)

Basic Operation and Features

INPUT UNDER VOLTAGE LOCKOUT

To prevent any instability to the converter, which may affect the end system, the ALQ25 series have been designed to turn-on once V_{IN} is in the voltage range of 34 - 36 VDC. Likewise, it has also been programmed to turn-off when V_{IN} drops down to 33 - 35 VDC.

OUTPUT VOLTAGE ADJUST/TRIM

The converter comes with a TRIM pin (PIN 6), which is used to adjust the output by as much as 90% to 110% of its set point. This is achieved by connecting an external resistor as described below.

To **INCREASE** the output, external R_{adj_up} resistor should be connected between TRIM PIN (Pin6) and +SENSE PIN (Pin 7). Please refer to Equation (1) for the required external resistance and output adjust relationship.

Equation (1):

$$R_{adj-up} = \frac{5.1 \times V_o \times (100 + \Delta\%)}{1.225 \times \Delta\%} - \frac{510}{\Delta\%} - 10.2(K\Omega)$$

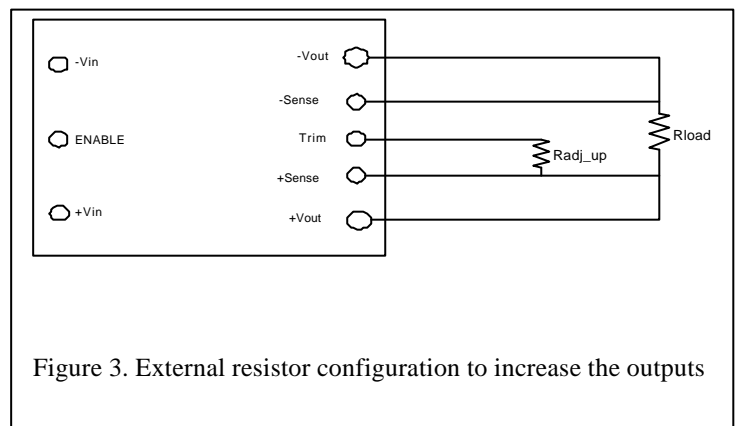

To **DECREASE** the output, external R_{adj_down} resistor should be connected between TRIM PIN (Pin 6) and -SENSE PIN (Pin 5). Please refer to Equation (2) for the required external resistance and output adjust relationship.

$$R_{adj-down} = \frac{510}{\Delta\%} - 10.2(K\Omega)$$

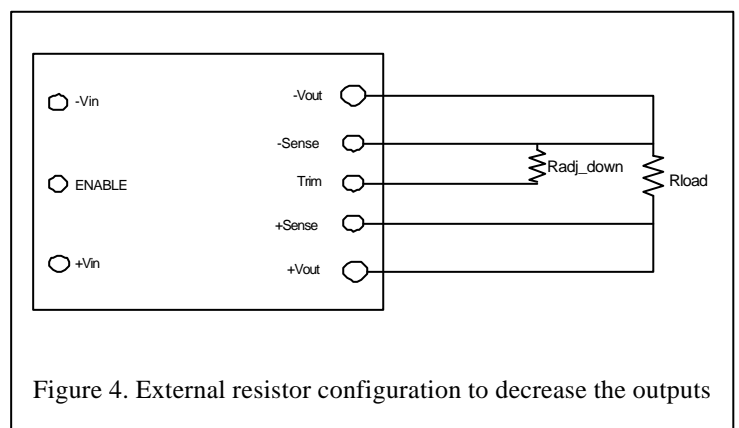



Technical Reference Notes
ALQ25 Series
(Open Frame Single Output Quarter Brick)



OUTPUT ENABLE

The ALQ25 series comes with an ENABLE pin (PIN 2), which is primarily used to turn ON/OFF the converter. Both a Positive (no part number suffix required) and a Negative (suffix "N" required) Enable Logic options are being offered. Please refer to Table 2 for the Part Numbering Scheme.

For Positive Enable, the converter is turned on when the ENABLE pin is at logic HIGH or left open. The unit turns off when the ENABLE pin is at logic LOW or directly connected to $-V_{IN}$. On the other hand, the Negative Enable version turns unit on when the ENABLE pin is at logic LOW or directly connected to $-V_{IN}$. The unit turns off when the ENABLE pin is at Logic HIGH.

OUTPUT OVER VOLTAGE PROTECTION (OVP)

The Over-Voltage Protection consists of circuitry that monitors the voltage on the output terminals. If the output voltage exceeds the Over Voltage Protection threshold limit, module will work on intermittent model. When the Over Voltage condition is removed, the module will automatically restart.

The protection mechanism is such that the unit can continue in this condition until the fault is cleared.

OVER CURRENT PROTECTION (OCP)

The Over Current Protection circuit comes in latching mode. The converter is latched off if the load current on the output reaches the OCP threshold limit. The OCP latch can be reset either by cycling the input voltage or toggling the Enable signal for 100ms. Consult factory for Auto-restart option.

The Over Current Protection (OCP) circuit comes in foldback current limit. If output current exceed the OCP threshold limit, or at a short circuit condition, the module will work on intermittent model. When the Over Current condition is removed, the module will automatically restart.

OVER TEMPERATURE PROTECTION (OTP)

These modules feature an over-temperature protection circuit to safeguard against thermal damage. The module will work on intermittent mode when the maximum device reference temperature is exceeded. When the over-temperature condition is removed, the converter will automatically restart



Technical Reference Notes

ALQ25 Series

(Open Frame Single Output Quarter Brick)



Performance Curves

ALQ25A48 (5.0V) SERIES

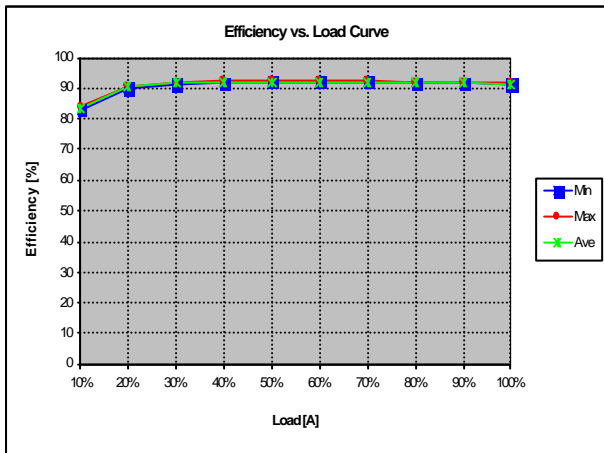

Figure 5. Efficiency vs. Load Current Curves at $T_A=25^\circ\text{C}$ for 36Vin

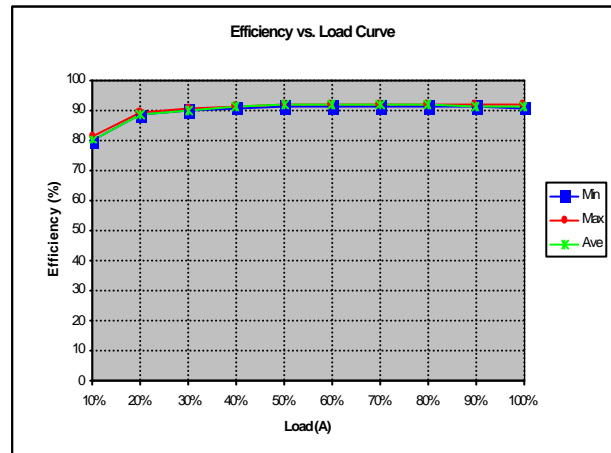

Figure 6. Efficiency vs Load Current Curves at $T_A=25^\circ\text{C}$ For 48Vin

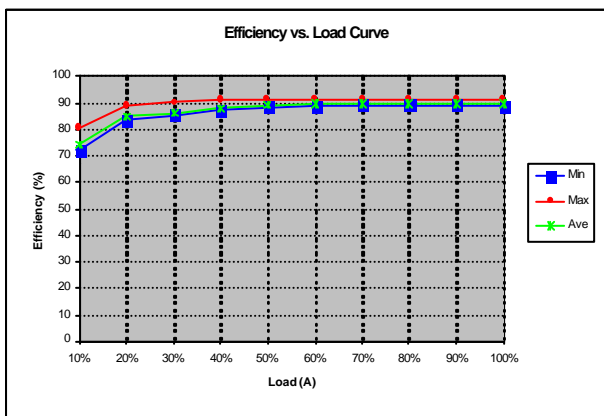
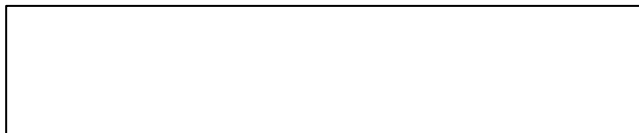

Figure 7. Figure 6. Efficiency vs Load Current Curves at $T_A=25^\circ\text{C}$ for 75Vin





Technical Reference Notes

ALQ25 Series

(Open Frame Single Output Quarter Brick)



CURRENT VS. TEMPERATURE CURVES

Derating curve of ALQ25A48.

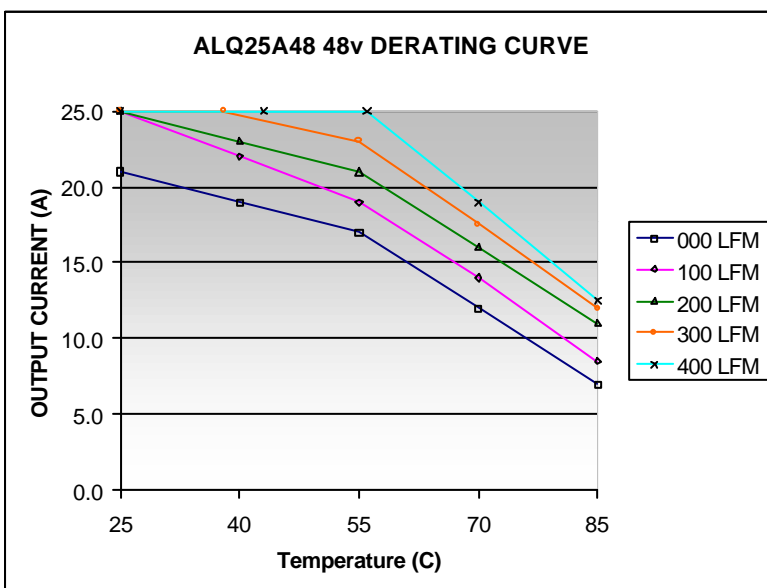
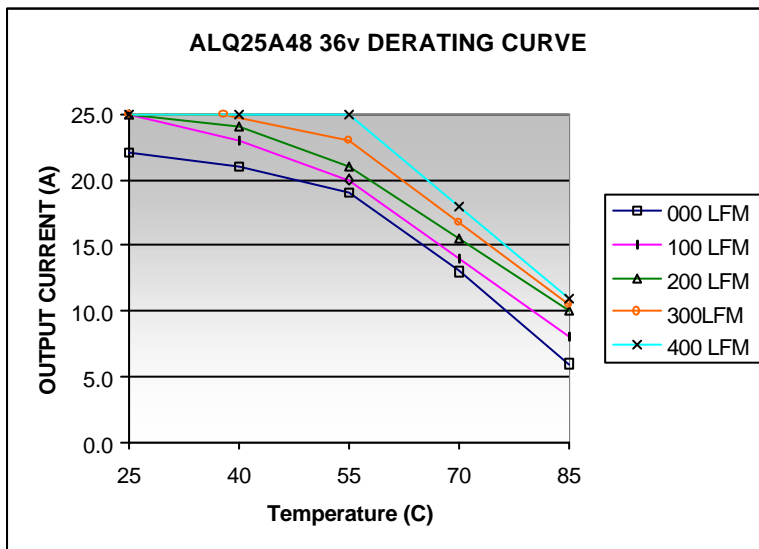



Technical Reference Notes
ALQ25 Series
(Open Frame Single Output Quarter Brick)

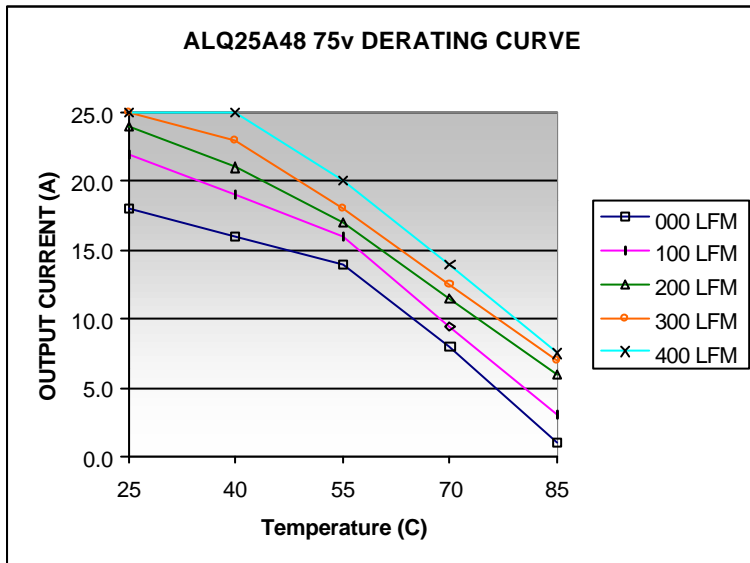

Mechanical Specifications

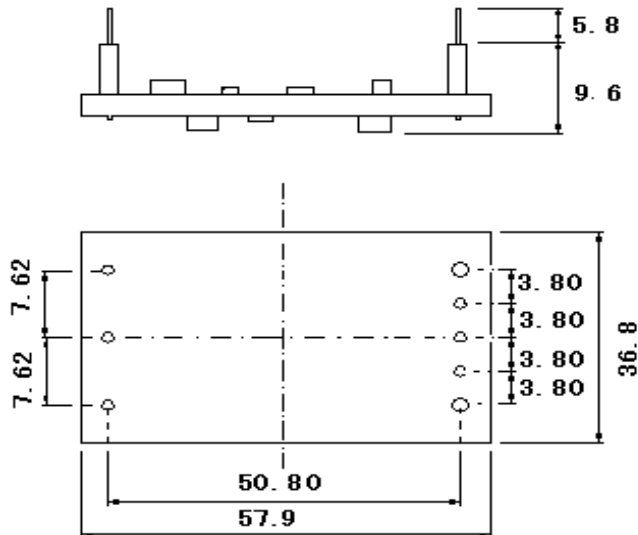

tolerances: X.X mm ± 0.5 mm

X.XX mm ± 0.25 mm

Figure 15. ALQ25 Series Mechanical Outline Drawing

Parameter	Device	Symbol	Min	Typ	Max	Unit
Dimension	All	L	-	2.28 [57.9]	-	in [mm]
		W	-	1.45 [36.8]	-	in [mm]
		H	-	0.43 [9.70]	-	in [mm]
Weight			-			g [oz]
PIN ASSIGNMENT						
J1	-V _{IN}	J5	-SENSE			
J2	ENABLE	J6	TRIM			
J3	+V _{IN}	J7	+SENSE			
J4	-V _O	J8	+V _O			



Technical Reference Notes
ALQ25 Series
(Open Frame Single Output Quarter Brick)



Mechanical Specifications *(continued)*

SOLDERING CONSIDERATIONS

The ALQ25 series converters are compatible with standard wave soldering techniques. When wave soldering, the converter pins should be preheated for 20-30 seconds at 110°C and wave soldered at 260°C for less than 10 seconds.

When hand soldering, the iron temperature should be maintained at 425°C and applied to the converter pins for less than 5 seconds. Longer exposure can cause internal damage to the converter. Cleaning can be performed with cleaning solvent IPA or with water.

PART NUMBERING SCHEME FOR ORDERING

OUTPUT CURRENT	OUTPUT VOLTAGE	INPUT VOLTAGE	ENABLE LOGIC
ALQ25	x	48	y
	A = 5.0V		N = Negative Enable "Blank" = Positive Enable (Default)

Please call 1-888-41-ASTEC for further inquiries or visit us at www.astecpower.com