

### Quad Voltage Monitor

The ISL88041 is a quad voltage-monitoring supervisor designed to monitor voltages  $\geq 0.7V$ . Low voltage detection circuitry protects the user's system from low voltage conditions, resetting the system when any of the monitored power supply voltages V1MON-V4MON fall below their respective minimum voltage thresholds. The reset signal remains asserted until all of these voltages return to proper operating levels and stabilize.

Each rail's VMON point is independently adjustable by using an external resistor divider. The VMON inputs will ignore transients of less than  $30\mu s$  on the monitored supplies, and the  $\overline{RST}$  output is guaranteed to be valid down to  $V_{DD} = 1V$ . The  $\overline{RST}$  output is open-drain to allow ORing of multiple signals and interfacing to a wide range of logic levels. Also, the  $\overline{MR}$  input allows the user to assert reset when this input is pulled low.

### Pinout

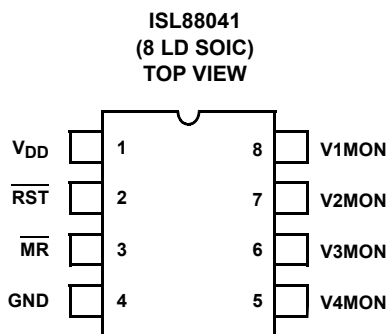

### Features

- Quad Voltage Monitoring
- Adjustable Voltage Inputs Monitor Voltages  $\geq 0.7V$
- Active-Low  $\overline{RST}$  Output
- Manual Reset Capability
- Reset Signal Valid Down to  $V_{DD} = 1V$
- Integrated  $20k\Omega$  Pull-Up Resistor on  $\overline{RST}$
- Glitch Immunity on Voltage Monitoring Inputs
- 8 Ld SOIC Pb-Free Plus Anneal Package (RoHS Compliant)

### Applications

- Graphics Cards
- Multi Voltage DSPs & Processors
- $\mu P$  Voltage Monitoring
- Embedded Control Systems
- Intelligent Instruments
- Medical Equipment
- Network Routers
- Portable Battery-Powered Equipment
- Set-Top Boxes
- Telecommunications Systems

### Ordering Information

PART NUMBER (Note)	PART MARKING	TEMP. RANGE (°C)	PACKAGE (Pb-Free)	PKG. DWG. #
ISL88041IBZ	88041IBZ	-40 to +85	8 Ld SOIC (Pb-free)	M8.15
ISL88041IBZ-T	88041IBZ	-40 to +85	8 Ld SOIC (Tape and Reel)	M8.15

NOTE: Intersil Pb-free plus anneal products employ special Pb-free material sets; molding compounds/die attach materials and 100% matte tin plate termination finish, which are RoHS compliant and compatible with both SnPb and Pb-free soldering operations. Intersil Pb-free products are MSL classified at Pb-free peak reflow temperatures that meet or exceed the Pb-free requirements of IPC/JEDEC J STD-020.

## ISL88041

### Pin Descriptions

ISL88041	PIN NAME	FUNCTION DESCRIPTION
1	V <sub>DD</sub>	Bias IC from nominal 2.7V to 4V.
2	$\overline{\text{RST}}$	Active-Low Open Drain Reset Output. Internal 20k $\Omega$ pull-up resistor to V <sub>DD</sub> .
3	$\overline{\text{MR}}$	Active Low Open Drain $\overline{\text{MR}}$ Input has a 10 $\mu\text{A}$ Pull-Up to V <sub>DD</sub> .
4	GND	Ground.
5	V1MON	Adjustable First Undervoltage Monitor Input
6	V2MON	Adjustable Second Undervoltage Monitor Input
7	V3MON	Adjustable Third Undervoltage Monitor Input
8	V4MON	Adjustable Forth Undervoltage Monitor Input

### Functional Block Diagram

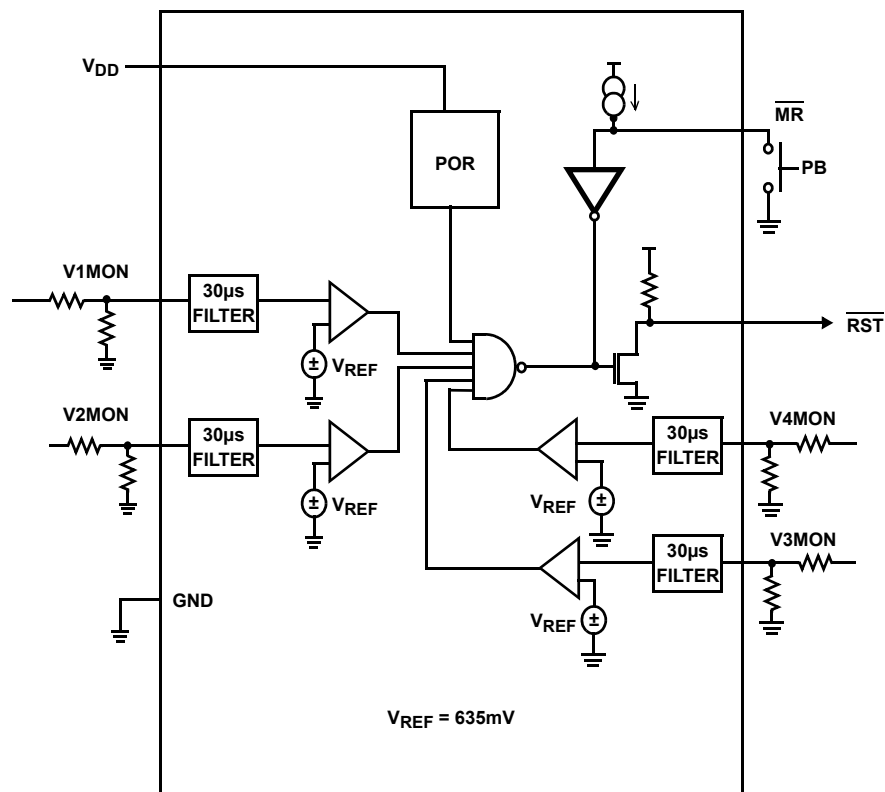

# ISL88041

## Absolute Maximum Ratings

V <sub>DD</sub> .....	+5.5V
V <sub>MON</sub> , $\overline{\text{RST}}$ , $\overline{\text{MR}}$ .....	-0.3V to V <sub>DD</sub> +0.3V
ESD Classification .....	4kV (HBM)

## Operating Conditions

V <sub>DD</sub> Supply Voltage Range .....	+2.7V to +4V
Temperature Range (T <sub>A</sub> ) .....	-40°C to 85°C

## Thermal Information

Thermal Resistance (Typical, Note 1)	θ <sub>JA</sub> (°C/W)
8 Ld SOIC .....	108
Maximum Junction Temperature .....	150°C
Maximum Storage Temperature Range .....	-65°C to 150°C
Maximum Lead Temperature (Soldering 10s) .....	300°C

CAUTION: Stresses above those listed in "Absolute Maximum Ratings" may cause permanent damage to the device. This is a stress only rating and operation of the device at these or any other conditions above those indicated in the operational sections of this specification is not implied.

### NOTES:

1. θ<sub>JA</sub> is measured in free air with the component mounted on a high effective thermal conductivity test board. See Tech Brief TB379 for details.
2. All voltages are relative to GND, unless otherwise specified.

## Electrical Specifications V<sub>DD</sub> = 3.3V, T<sub>A</sub> = T<sub>J</sub> = -40°C - 85°C, Unless Otherwise Specified

SYMBOL	PARAMETER	TEST CONDITIONS	MIN	TYP	MAX	UNIT
<b>BIAS</b>						
V <sub>DD</sub>	Supply Voltage Range		2.7		4.0	V
I <sub>DD</sub>	V <sub>DD</sub> Supply Current	V <sub>MON</sub> > V <sub>REF</sub>		165	1000	μA
V <sub>DD_LO</sub>	V <sub>DD</sub> Lock Out	V <sub>DD</sub> low to high		2.6		V
V <sub>DD_LOR</sub>	V <sub>DD</sub> Lock Out Reset	V <sub>DD</sub> high to low		2.4		V
<b>V<sub>MON</sub></b>						
V <sub>REF</sub>	Adj. Reset Threshold Voltage		619	635	651	mV
V <sub>REFHYST</sub>	Hysteresis of V <sub>REF</sub>			10		mV
V <sub>REF_RNG</sub>	Range	V <sub>REF</sub> (max) - V <sub>REF</sub> (min)		1.8		mV
t <sub>FIL</sub>	Glitch Filter Duration	V <sub>MON</sub> glitch to $\overline{\text{RST}}$ low Filter		30		μs
<b>RESET</b>						
I <sub>PD</sub>	Pull-Down Current	$\overline{\text{RST}} = 0.5V$		2		mA
R <sub>PU</sub>	Internal Pull-up Resistance			20		kΩ
V <sub>OL</sub>	Output Low	V <sub>DD</sub> = 1V		0.05	0.1	V
t <sub>RPD</sub>	V <sub>TH</sub> to Reset Asserted Delay	Last valid input = V <sub>TH</sub> to $\overline{\text{RST}}$ release		1.5		μs
<b>MANUAL RESET</b>						
V <sub>MR</sub>	$\overline{\text{MR}}$ Input Voltage	$\overline{\text{MR}}$ low to high threshold	0.4V <sub>DD</sub>	0.5V <sub>DD</sub>	0.6V <sub>DD</sub>	V
V <sub>MRHYST</sub>	Hysteresis of V <sub>MR</sub>			0.065		V
I <sub>PU</sub>	Pull-up Current	$\overline{\text{MR}} = 0.5V$		10		μA
t <sub>MD</sub>	$\overline{\text{MR}}$ to Deassert Reset Out Delay	$\overline{\text{MR}}$ high to $\overline{\text{RST}}$ release		50		ns
t <sub>MR</sub>	$\overline{\text{MR}}$ to Assert Reset Out Delay	$\overline{\text{MR}}$ low to $\overline{\text{RST}}$ pulling low		15		ns

## ISL88041 Description and Operation

The ISL88041 is a four voltage detection IC designed to monitor multiple voltages  $\geq 0.7V$ . This IC is suitable for microprocessors or industrial system applications providing both reset and manual reset functions.

### $V_{DD}$ Lock Out

Applying power to the ISL88041  $V_{DD}$  activates a lock out circuit which disables the reporting function until  $V_{DD}$  rises to  $\sim 2.6V$ . As  $V_{DD}$  bias is applied the  $\overline{RST}$  output is held low before  $V_{DD} = 1V$ . If  $V_{DD}$  falls below  $\sim 2.4V$  the lock out of monitoring and reporting functions is invoked.

### Low Voltage Monitoring

Once biased to 2.7V the IC continuously monitors and reports from one to four voltages independently through external resistor dividers comparing each VMON pin voltage to a nominal internal 0.635V reference. Once all VMON input voltages rise above this threshold, the  $\overline{RST}$  output is immediately deasserted by being released to be pulled high via its internal 20k $\Omega$  (or optional external) pull resistor to  $V_{DD}$  indicating that all the minimum voltage conditions have been met (see Figure 4). The  $\overline{RST}$  output is open-drain to allow ORing of signals and interfacing to a range of logic levels. Once any VMON input falls below its respective user-set threshold, the  $\overline{RST}$  output is pulled low after the glitch filter delay ( $t_{FIL}$ ) as the VMON inputs are designed to reject short undervoltage transients of approximately 30 $\mu s$  (see Figure 5). The user can customize the individual rail

undervoltage threshold ( $V_{TRIP}$ ) by connecting individual VMON pins to an external resistor divider according to the following formula:

$$V_{TRIP} = 0.635V(R1+R2)/R2$$

See Figure 8 for a typical application configuration.

### Manual Reset

The manual-reset input ( $\overline{MR}$ ) allows the user to trigger a reset by using a push-button switch or by signaling the input low. Reset is asserted and deasserted immediately upon  $\overline{MR}$  transitioning through  $\overline{MR}_{VTH}$ , see Figures 6 and 7.

Figure 1 is the operational timing diagram.

### Using the ISL88041EVAL1

The ISL88041EVAL1 is the evaluation platform for this product and illustrates the flexibility and simplicity of monitoring four separate voltages. The  $\overline{RST}$  output can be monitored once the  $V_{DD}$ , GND, and appropriate 3.3V, 2.5V, 1.8V and 1.2V supply voltage inputs are properly biased as labeled. A Manual Reset ( $\overline{MR}$ ) input is also available for evaluation.

The circuit as shown in Figures 10 and 11 has resistor dividers chosen to monitor for an undervoltage threshold level of 89% of the 4 nominal voltages. Figure 1 illustrates the expected behavior and Figures 4 through 7 illustrate the actual IC performance in the ISL88041EVAL1.

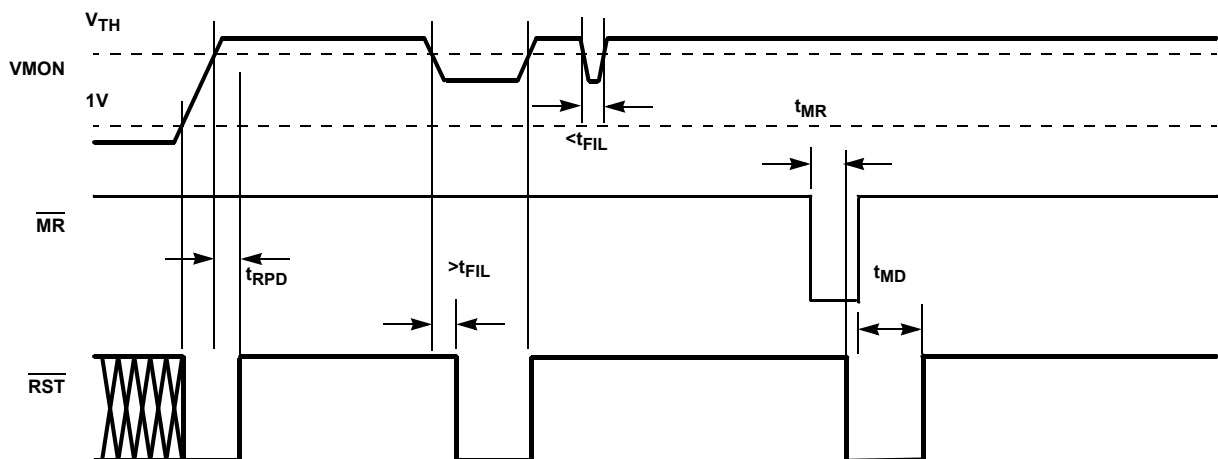

FIGURE 1. ISL88041 OPERATIONAL TIMING DIAGRAM

Typical Performance Curves

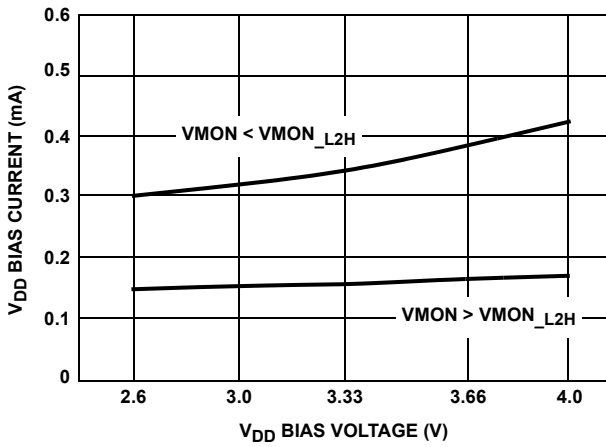

Figure 2 illustrates the idle and active bias currents levels.

FIGURE 2. V<sub>DD</sub> CURRENT vs V<sub>DD</sub> VOLTAGE

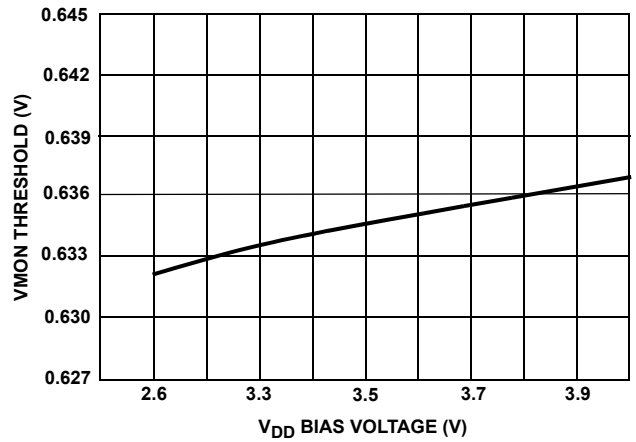
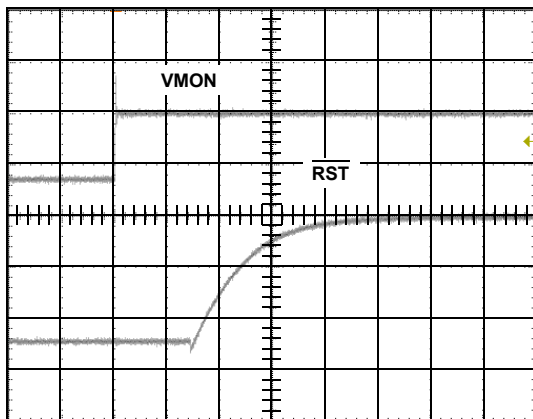
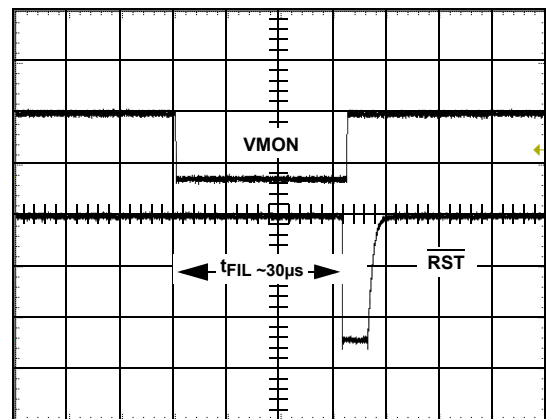

Figure 3 shows the VMON threshold shift over the bias range, demonstrating a PSRR of 105dB.

FIGURE 3. VMON THRESHOLD vs V<sub>DD</sub> VOLTAGE



RST = 2V/DIV  
VMON = 1V/DIV  
1µs/DIV  
FIGURE 4. VMON HIGH TO RST HIGH



RST = 2V/DIV  
VMON = 1V/DIV  
10µs/DIV  
FIGURE 5. VMON LOW TO RST LOW

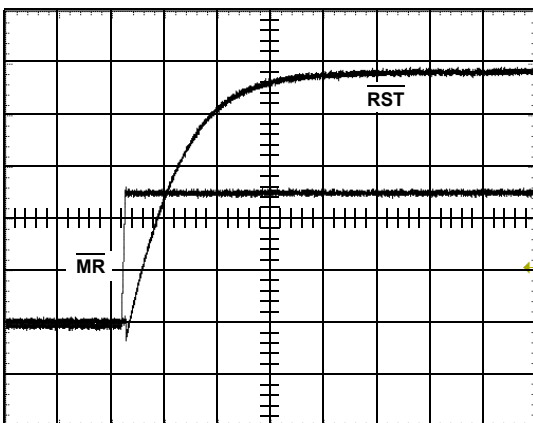

RST = 1V/DIV  
MR = 1V/DIV  
1µs/DIV  
FIGURE 6. MR HIGH TO RST HIGH

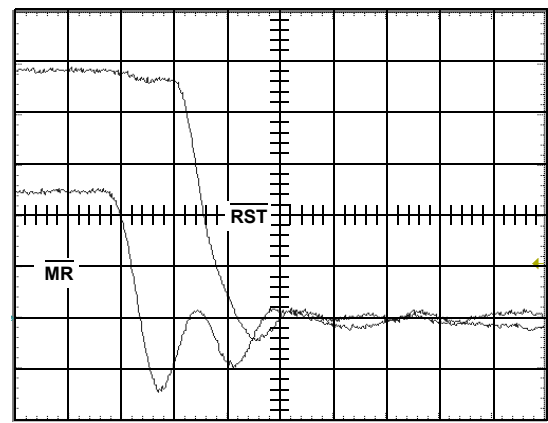

MR = 1V/DIV  
RST = 1V/DIV  
10ns/DIV  
FIGURE 7. MR LOW TO RST LOW

Typical Performance Curves (Continued)

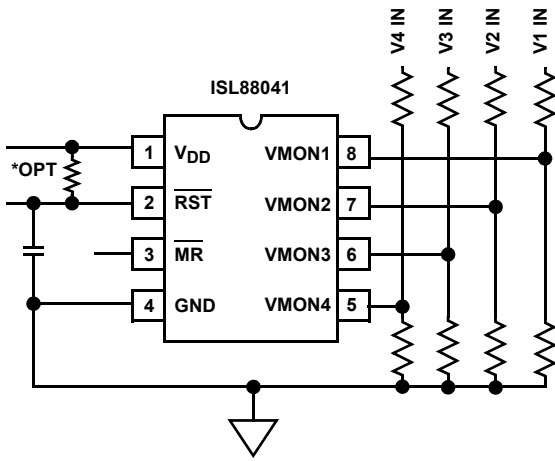

FIGURE 8. ISL88041 TYPICAL APPLICATION SCHEMATIC

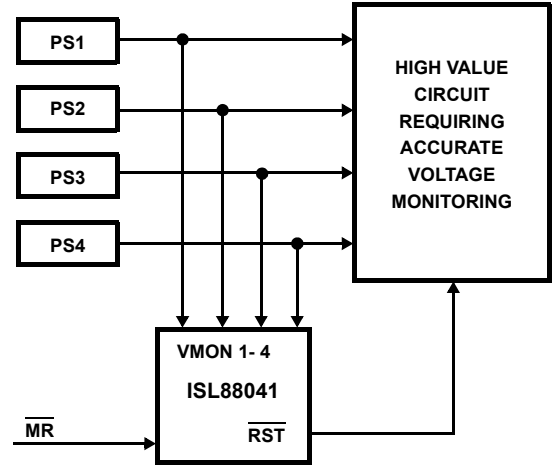

FIGURE 9. TYPICAL ISL88041 APPLICATION DIAGRAM

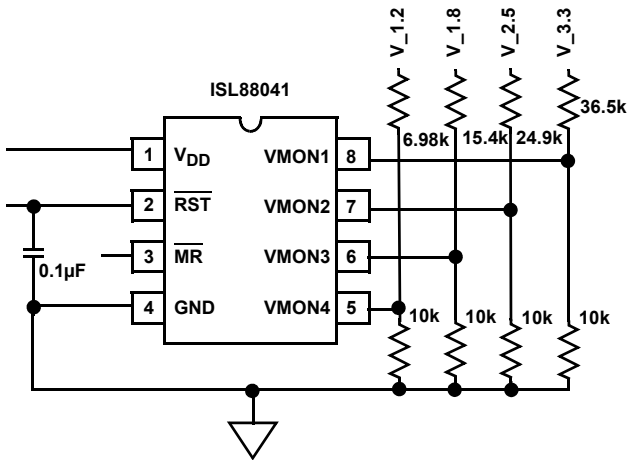
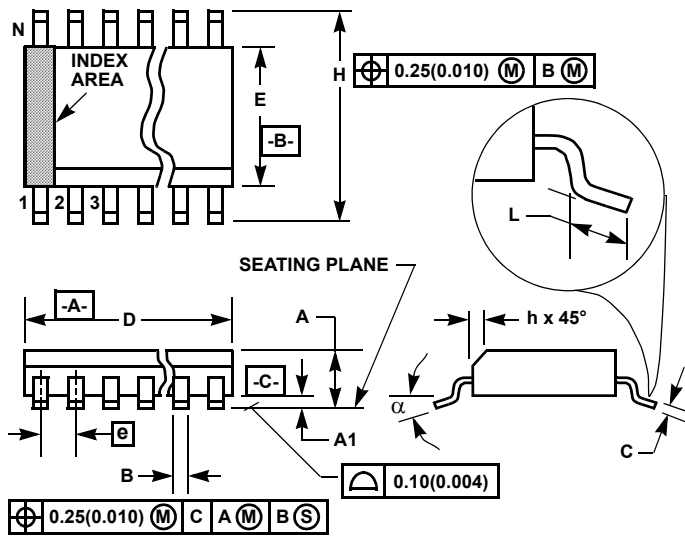

FIGURE 10. ISL88041EVAL1 SCHEMATIC



FIGURE 11. ISL88041EVAL1 PHOTO

### Small Outline Plastic Packages (SOIC)



#### NOTES:

1. Symbols are defined in the "MO Series Symbol List" in Section 2.2 of Publication Number 95.
2. Dimensioning and tolerancing per ANSI Y14.5M-1982.
3. Dimension "D" does not include mold flash, protrusions or gate burrs. Mold flash, protrusion and gate burrs shall not exceed 0.15mm (0.006 inch) per side.
4. Dimension "E" does not include interlead flash or protrusions. Interlead flash and protrusions shall not exceed 0.25mm (0.010 inch) per side.
5. The chamfer on the body is optional. If it is not present, a visual index feature must be located within the crosshatched area.
6. "L" is the length of terminal for soldering to a substrate.
7. "N" is the number of terminal positions.
8. Terminal numbers are shown for reference only.
9. The lead width "B", as measured 0.36mm (0.014 inch) or greater above the seating plane, shall not exceed a maximum value of 0.61mm (0.024 inch).
10. Controlling dimension: MILLIMETER. Converted inch dimensions are not necessarily exact.

#### M8.15 (JEDEC MS-012-AA ISSUE C)

#### 8 LEAD NARROW BODY SMALL OUTLINE PLASTIC PACKAGE

SYMBOL	INCHES		MILLIMETERS		NOTES
	MIN	MAX	MIN	MAX	
A	0.0532	0.0688	1.35	1.75	-
A1	0.0040	0.0098	0.10	0.25	-
B	0.013	0.020	0.33	0.51	9
C	0.0075	0.0098	0.19	0.25	-
D	0.1890	0.1968	4.80	5.00	3
E	0.1497	0.1574	3.80	4.00	4
e	0.050 BSC		1.27 BSC		-
H	0.2284	0.2440	5.80	6.20	-
h	0.0099	0.0196	0.25	0.50	5
L	0.016	0.050	0.40	1.27	6
N	8		8		7
$\alpha$	0°	8°	0°	8°	-

Rev. 1 6/05

All Intersil U.S. products are manufactured, assembled and tested utilizing ISO9000 quality systems.

Intersil Corporation's quality certifications can be viewed at [www.intersil.com/design/quality](http://www.intersil.com/design/quality)

*Intersil products are sold by description only. Intersil Corporation reserves the right to make changes in circuit design, software and/or specifications at any time without notice. Accordingly, the reader is cautioned to verify that data sheets are current before placing orders. Information furnished by Intersil is believed to be accurate and reliable. However, no responsibility is assumed by Intersil or its subsidiaries for its use; nor for any infringements of patents or other rights of third parties which may result from its use. No license is granted by implication or otherwise under any patent or patent rights of Intersil or its subsidiaries.*

For information regarding Intersil Corporation and its products, see [www.intersil.com](http://www.intersil.com)