

RoHS Compliant Product
A suffix of "-C" specifies halogen & lead-free

FEATURES

- PN Junction Guard Ring for Transient and ESD Protection
- Fast Switching
- Low Turn-on Voltage

MECHANICAL DATE

- Terminals: Solderable per MIL-STD-202, Method 208
- Polarity: See Diagrams Below
- Weight: 0.008 grams (approx.)
- Mounting Position: Any

MARKING

LD3 / KL4

PACKAGE INFORMATION

Package	MPQ	Leader Size
SOT-23	3K	7 inch

SOT-23

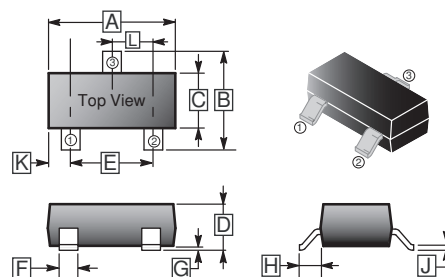

REF.	Millimeter		REF.	Millimeter	
	Min.	Max.		Min.	Max.
A	2.80	3.04	G	0.09	0.18
B	2.10	2.55	H	0.45	0.60
C	1.20	1.40	J	0.08	0.177
D	0.89	1.15	K	0.6 REF.	
E	1.78	2.04	L	0.89	1.02
F	0.30	0.50			

Top View

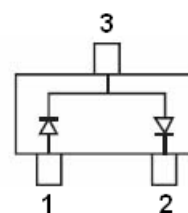

ABSOLUTE MAXIMUM RATINGS (T_J=25°C unless otherwise specified)

Parameter	Symbol	Ratings	Unit
Maximum Reverse Voltage	V _R	30	V
Peak Forward Surge Current@ t<1s	I _{FSM}	600	mA
Maximum Forward Current (DC)	I _F	200	mA
Junction, Storage Temperature	T _J , T _{STG}	125, -55~150	°C

ELECTRICAL CHARACTERISTICS (T_A=25°C unless otherwise specified)

Parameters	Symbol	Min.	Typ.	Max.	Unit	Test Condition
Reverse Voltage	V _(BR)	30	-	-	V	I _R =10μA
Maximum Instantaneous Forward Voltage	V _F	-	-	0.24	V	I _F =0.1mA
		-	-	1		I _F =100mA
Maximum Average Reverse Current	I _R	-	-	2	μA	V _R =25V
Reverse Recovery Time	T _{RR}	-	-	5	nS	I _F =I _R =10mA, I _{R(REC)} =1mA
Total Capacitance	C _{tot}	-	-	10	pF	V _R =1V, f= 1MHz

RATINGS AND CHARACTERISTIC CURVES

Forward Voltage

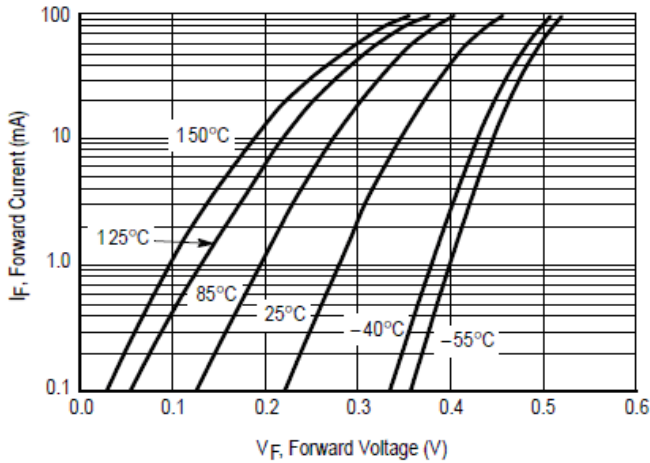

Leakage Current

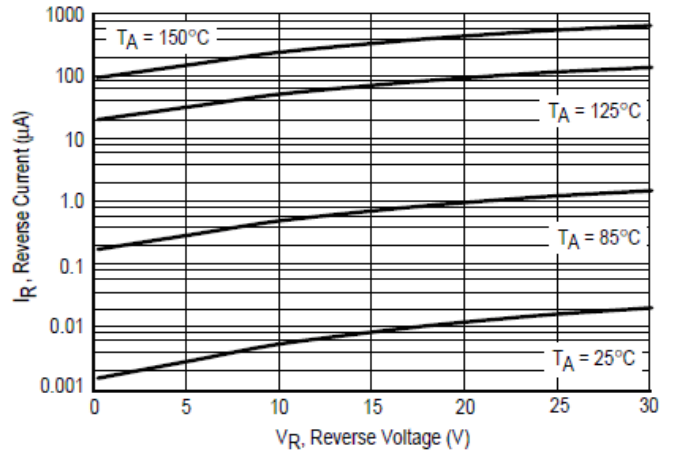

Total Capacitance

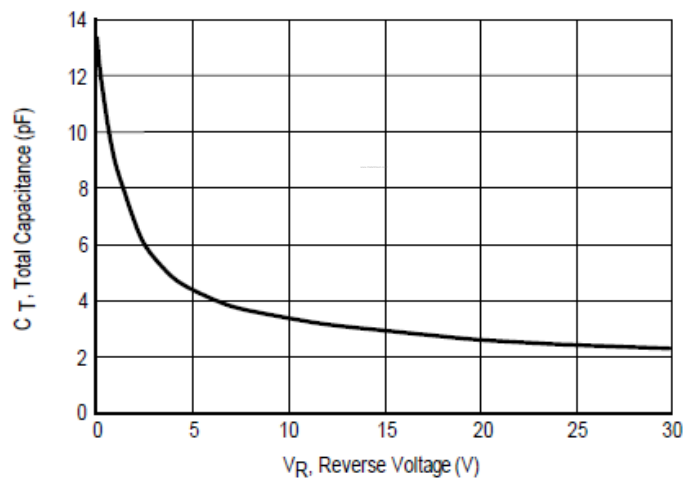

Recovery Time Equivalent Test Circuit

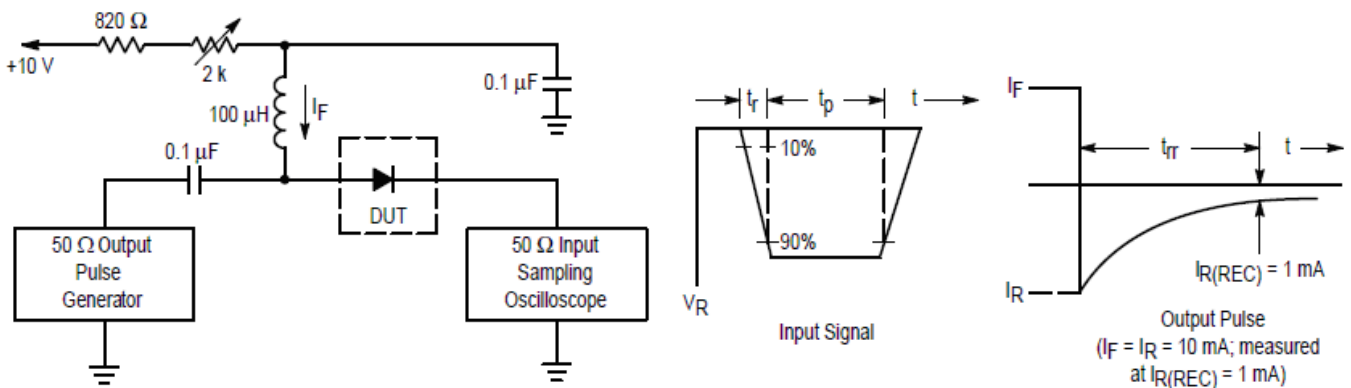

Note:

1. A 2.0 K Ω variable resistor adjusted for a I_F of 10mA.
2. $T_p \gg T_{RR}$
3. Input pulse is adjusted so $I_{R(\text{peak})}$ is equal to 10mA.