

ORANGE

Item No.: 190210

1. This specification applies to GaAsP / GaP LED Chips
2. Structure
 - 2.1 Mesa structure
 - 2.2 Electrodes

p-side (anode)	Au alloy
n-side (cathode)	Au alloy
3. Outlines (dimensions in microns)

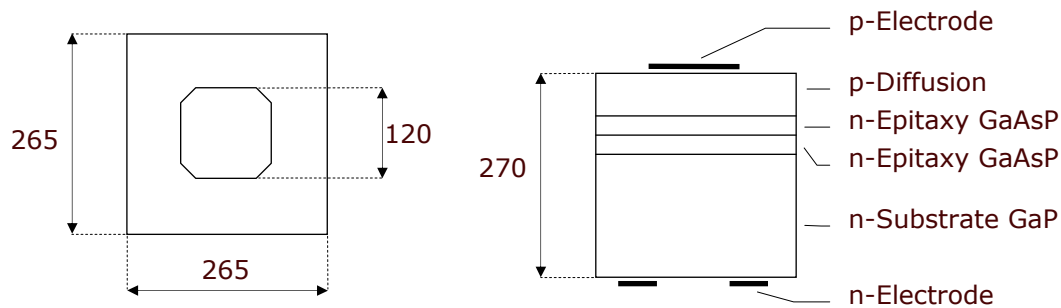

Wire bond contacts can also be circular or square

4. Electrical and optical characteristics (T=25°C)

Parameter	Symbol	Conditions	min	typ	max	Unit
Forward voltage	V_F	$I_F = 20 \text{ mA}$		2,10	2,50	V
Reverse current	I_R	$V_R = 5 \text{ V}$			10	μA
Luminous intensity *	I_V	$I_F = 20 \text{ mA}$	2,0	3,0		mcd
Peak wavelength	λ_P	$I_F = 20 \text{ mA}$		635		nm

* On request, wafers will be delivered according to luminous intensity classes
Brightness measurement at OSA on gold plate

5. Packing
 - Dice on adhesive film with 1) wire bond side on top
 - 2) back contact on top

6. Labeling

Type	Lot No.	I_V typ min max	Quantity
------	---------	-------------------------	----------