

# AU OPTRONICS CORPORATION

## Product Specification

### 17.0" SXGA Color TFT-LCD Module

**Model Name: M170EG01 V.5**

| Approved by | Prepared by |
|-------------|-------------|
|             |             |

*DDBU Marketing Division / AU Optronics*

| Customer | Checked & Approved by |
|----------|-----------------------|
|          |                       |

## Product Specification

### 17.0" SXGA Color TFT-LCD Module Model Name: M170EG01 V.5

Preliminary Specifications  
 Final Specifications

Note: This Specification is subject to change without notice.

# Contents

|   |           |
|---|-----------|
| <b>1.0 Handling Precautions .....</b>           | <b>6</b>  |
| <b>2.0 General Description .....</b>            | <b>7</b>  |
| 2.1 Display Characteristics.....                | 7         |
| 2.2 Functional Block Diagram.....               | 8         |
| 2.3 Optical Characteristics .....               | 9         |
| 2.4 Pixel format image.....                     | 12        |
| <b>3.0 Electrical characteristics.....</b>      | <b>13</b> |
| 3.1 Absolute Maximum Ratings .....              | 13        |
| 3.2 Connectors .....                            | 14        |
| 3.3 Signal Pin.....                             | 14        |
| 3.4 Signal Description .....                    | 15        |
| 3.5 Signal Electrical Characteristics .....     | 18        |
| 3.6 Interface Timings .....                     | 18        |
| 3.6.1 Timing Characteristics .....              | 18        |
| 3.6.2 Timing Definition.....                    | 19        |
| 3.8 Power ON/OFF Sequence .....                 | 21        |
| <b>4.0 Backlight Characteristics .....</b>      | <b>22</b> |
| 4.1 Signal for Lamp connector .....             | 22        |
| 4.2 Parameter guideline for CCFL Inverter ..... | 22        |
| <b>5.0 Vibration, Shock, and Drop .....</b>     | <b>23</b> |
| 5.1 Vibration & Shock .....                     | 23        |
| 5.2 Drop test.....                              | 23        |
| <b>6.0 Environment .....</b>                    | <b>23</b> |
| 6.1 Temperature and Humidity .....              | 23        |
| 6.1.1 Operating Conditions .....                | 23        |
| 6.1.2 Shipping Conditions.....                  | 23        |
| 6.2 Atmospheric Pressure.....                   | 24        |
| 6.3 Thermal Shock .....                         | 24        |
| <b>7.0 Reliability.....</b>                     | <b>24</b> |
| 7.1 Failure Criteria.....                       | 24        |
| 7.2 Failure Rate .....                          | 24        |
| 7.2.1 Usage .....                               | 24        |
| <b>8.0 Safety.....</b>                          | <b>25</b> |
| 8.1 Sharp Edge Requirements .....               | 25        |
| 8.2 Materials.....                              | 25        |
| 8.2.1 Toxicity.....                             | 25        |
| 8.2.2 Flammability .....                        | 25        |
| 8.3 Capacitors .....                            | 25        |

**9.0 Other requirement..... 26**

    9.1 National Test Lab Requirement .....26

    9.2 Label .....26

**10.0 Mechanical Characteristics ..... 27**

## Record of Revision

| Version and Date | Page | Old description            | New Description | Remark |
|------------------|------|----------------------------|-----------------|--------|
| 0.1 2005/2/28    | All  | First Edition for Customer | All             |        |

## 1.0 Handling Precautions

- 1) Since front polarizer is easily damaged, pay attention not to scratch it.
- 2) Be sure to turn off power supply when inserting or disconnecting from input connector.
- 3) Wipe off water drop immediately. Long contact with water may cause discoloration or spots.
- 4) When the panel surface is soiled, wipe it with absorbent cotton or other soft cloth.
- 5) Since the panel is made of glass, it may break or crack if dropped or bumped on hard surface.
- 6) Since CMOS LSI is used in this module, take care of static electricity and insure human earth when handling.
- 7) Do not open nor modify the Module Assembly.
- 8) Do not press the reflector sheet at the back of the module to any directions.
- 9) In case if a module has to be put back into the packing container slot after once it was taken out from the container, do not press the center of the CCFL reflector edge. Instead, press at the far ends of the CCFL reflector edge softly. Otherwise the TFT module may be damaged.
- 10) At the insertion or removal of the Signal Interface Connector, be sure not to rotate nor tilt the Interface Connector of the TFT module.
- 11) After installation of the TFT module into an enclosure (Desktop monitor Bezel, for example), do not twist nor bend the TFT Module even momentary. At designing the enclosure, it should be taken into consideration that no bending/twisting forces are applied to the TFT module from outside. Otherwise the TFT module may be damaged.

## 2.0 General Description

This specification applies to the 17.0 inch Color TFT/LCD Module M170EG01 V5.

This module is designed for a display unit of personal computer.

The display supports the SXGA (1280(H) x 1024(V)) screen format and 16.2M colors (RGB 6-bits + FRC data).

All input signals are 2 Channel LVDS interface compatible.

This module does not contain an inverter card for backlight.

## 2.1 Display Characteristics

The following items are characteristics summary on the table under 25 condition:

| ITEMS                                       | Unit                 | SPECIFICATIONS                                    |          |       |       |
|---|----------------------|---|----------|-------|-------|
| Screen Diagonal                             | [mm]                 | 432(17.0")  |          |       |       |
| Active Area                                 | [mm]                 | 337.920 (H) x 270.336(V)                          |          |       |       |
| Pixels H x V                                |                      | 1280(x3) x 1024                                   |          |       |       |
| Pixel Pitch                                 | [mm]                 | 0.264 (per one triad) x 0.264                     |          |       |       |
| Pixel Arrangement                           |                      | R.G.B. Vertical Stripe                            |          |       |       |
| Display Mode                                |                      | Normally White                                    |          |       |       |
| White Luminance                             | [cd/m <sup>2</sup> ] | 260 (Typ)   |          |       |       |
| Contrast Ratio                              |                      | 450 : 1 (Typ)                                     |          |       |       |
| Optical Rise Time/Fall Time                 | [msec]               | 16 (Typ)  |          |       |       |
| Color Saturation                            |                      | 72% NTSC  |          |       |       |
| Nominal Input Voltage VDD                   | [Volt]               | +5.0 V  |          |       |       |
| Power Consumption<br>(VDD line + CCFL line) | [Watt]               | 25.8 W(Typ)<br>(PDD=6 W, PCFL=19.8 W @Lamp=7.5mA) |          |       |       |
| Weight                                      | [Grams]              | 1900 (Typ)  |          |       |       |
| Physical Size                               | [mm]                 |   | Min.     | Typ.  | Max.  |
|   |                      | Horizatal(H)                                      | 358      | 358.5 | 359.0 |
|   |                      | Vertical(V)                                       | 296      | 296.5 | 297   |
|   |                      | Depth(D)  | 16.5     | 17.0  | 17.5  |
| Electrical Interface                        |                      | Dual Channel LVDS                                 |          |       |       |
| Support Color                               |                      | 16.2M colors (RGB 6-bit + FRC data)               |          |       |       |
| Temperature Range                           |                      |   |          |       |       |
|   | Operating            | [°C]  | 0 to +50 |       |       |
| Storage (Shipping)                          | [°C]                 | -20 to +60  |          |       |       |

## 2.2 Functional Block Diagram

The following diagram shows the functional block of the 17.0 inches Color TFT/LCD Module:

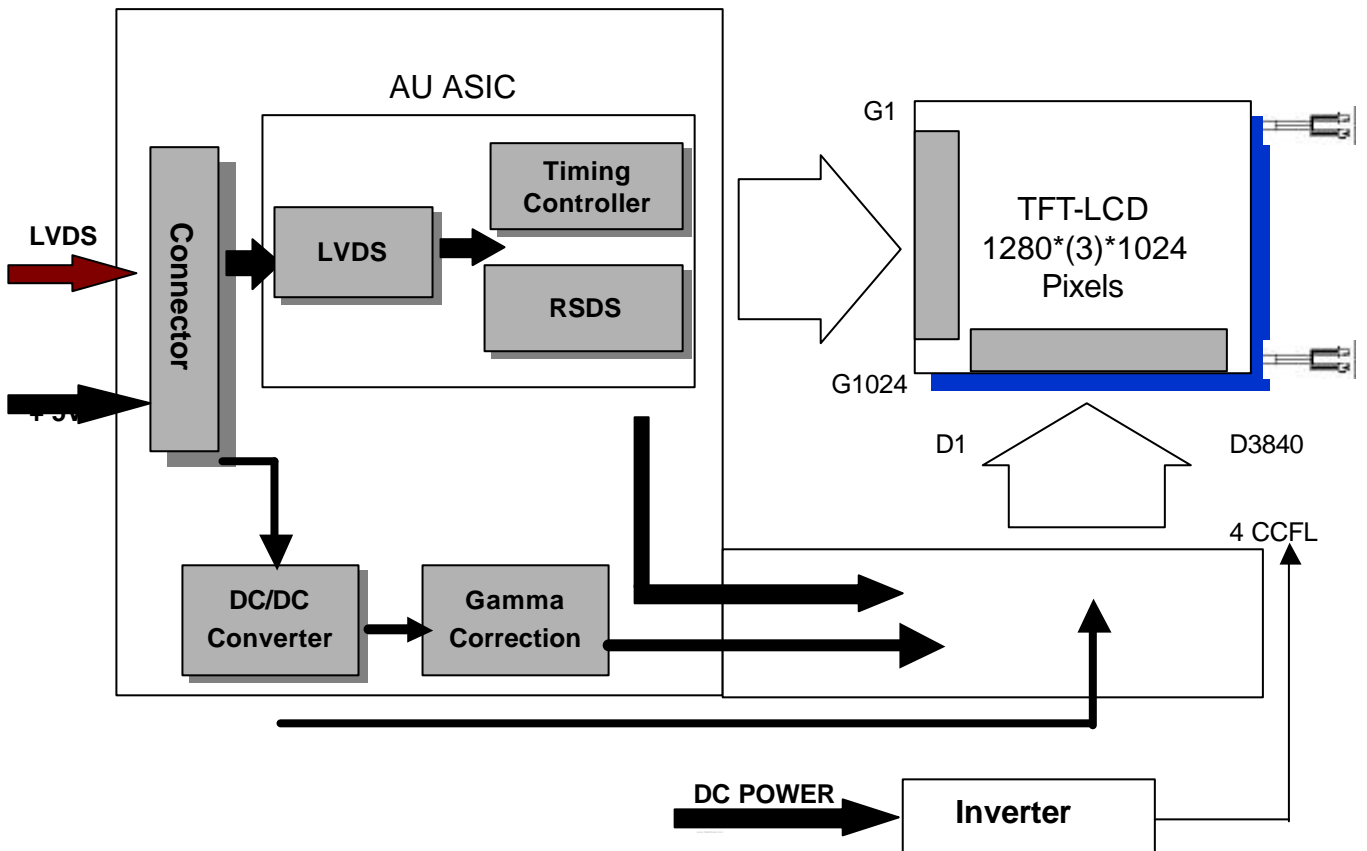

FI-XB30SRL-HF11 / MDF76LBRW-30S-1H

JST-BHSR-02VS-1 ( 2pin x2 )

Mating Type: JAE FI-X30C2L / HRS MDF76G-30P-1SD

SM02B-BHSS-1-TB



### 2.3 Optical Characteristics

The optical characteristics are measured under stable conditions at 25 (Room Temperature):

| Item                                   | Unit                 | Conditions                           | Min.     | Typ.     | Max. | Note          |
|--|----------------------|--------------------------------------|----------|----------|------|---------------|
| Viewing Angle                          | [degree]             | Horizontal (Right)<br>CR = 10 (Left) | 60<br>60 | 70<br>70 | -    | -             |
|  |                      | Vertical (Up)<br>CR = 10 (Down)      | 60<br>50 | 70<br>60 | -    | -             |
|  |                      | Horizontal (Right)<br>CR = 5 (Left)  | 70<br>70 | 80<br>80 |      |               |
|  |                      | Vertical (Up)<br>CR = 5 (Down)       | 70<br>70 | 80<br>80 |      |               |
| Contrast ratio                         |                      | Normal Direction                     | 250      | 450      | -    | -             |
| Response Time                          | [msec]               | Rising Time                          | -        | 12       | 20   | <b>Note 1</b> |
|  |                      | Falling Time                         | -        | 4        | 5    |               |
|  |                      | Rising + Falling                     | -        | 16       | 25   |               |
| Color / Chromaticity Coordinates (CIE) |                      | Red x                                | 0.61     | 0.64     | 0.67 | -             |
|  |                      | Red y                                | 0.31     | 0.34     | 0.37 | -             |
|  |                      | Green x                              | 0.26     | 0.29     | 0.32 | -             |
|  |                      | Green y                              | 0.58     | 0.61     | 0.64 | -             |
|  |                      | Blue x                               | 0.11     | 0.14     | 0.17 | -             |
|  |                      | Blue y                               | 0.04     | 0.07     | 0.10 | -             |
| Color Coordinates (CIE) White          |                      | White x                              | 0.28     | 0.31     | 0.34 | -             |
|  |                      | White y                              | 0.30     | 0.33     | 0.36 | -             |
| White Luminance @ CCFL 7.5mA (center)  | [cd/m <sup>2</sup> ] |                                      | 210      | 260      |      | -             |
| Luminance Uniformity                   | [%]                  |                                      | 75       | 80       |      | <b>Note 2</b> |
| Crosstalk (in 75Hz)                    | [%]                  |                                      |          |          | 1.5  | <b>Note 3</b> |
| Flicker                                | dB                   |                                      |          |          | -20  | <b>Note 4</b> |

**Equipment:** Pattern Generator, Power Supply, Digital Voltmeter, Luminance meter

(PR 880, BM-5A / BM7, CS-1000, CA210, SR\_3, EZ Contrast\*, Optiscope& Westar TRD-100)

Aperture 1 ° with 100cm VD or 2 ° with 50cm viewing distance

Test Point Center (VESA point 9)

Environment < 1 lux

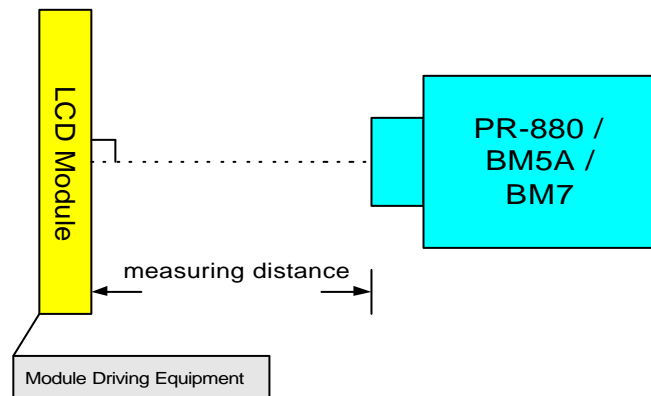

\* EZ Contrast is a different measurement tool with very close viewing distance.

**Note 1: Definition of Response time**

The output signals of photodetector are measured when the input signals are changed from 'Full Black' to 'Full White' (rising time), and from 'Full White' to 'Full Black' (falling time), respectively. The response time is interval between the 10% and 90% of amplitudes.

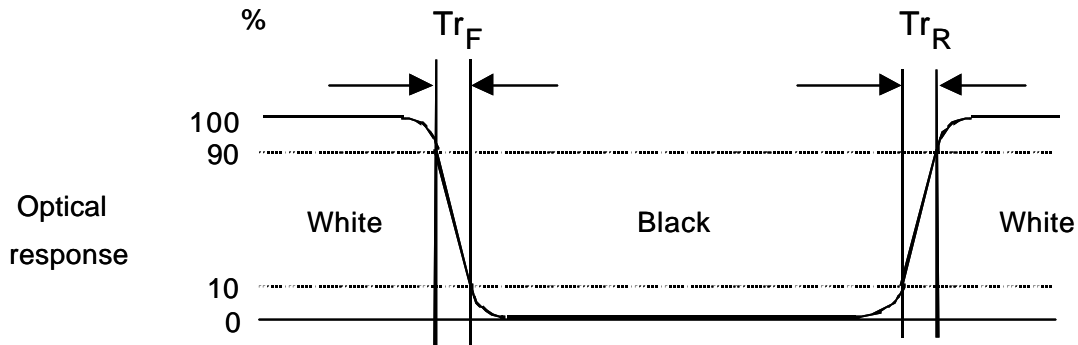

**Note 2: Brightness uniformity of these 9 points is defined as below**

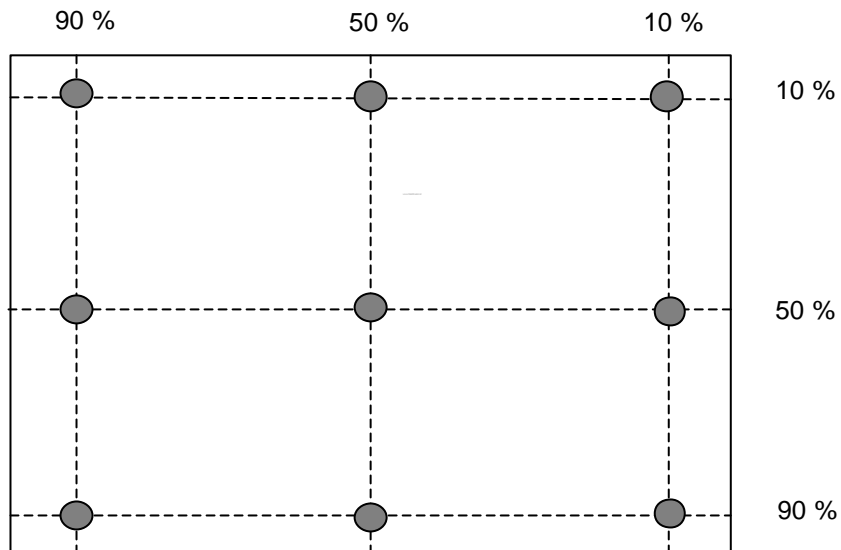

$$\text{Uniformity} = \frac{\text{Minimum Luminance in 9 points (1-9)}}{\text{Maximum Luminance in 9 Points (1-9)}}$$

**Note 3:**

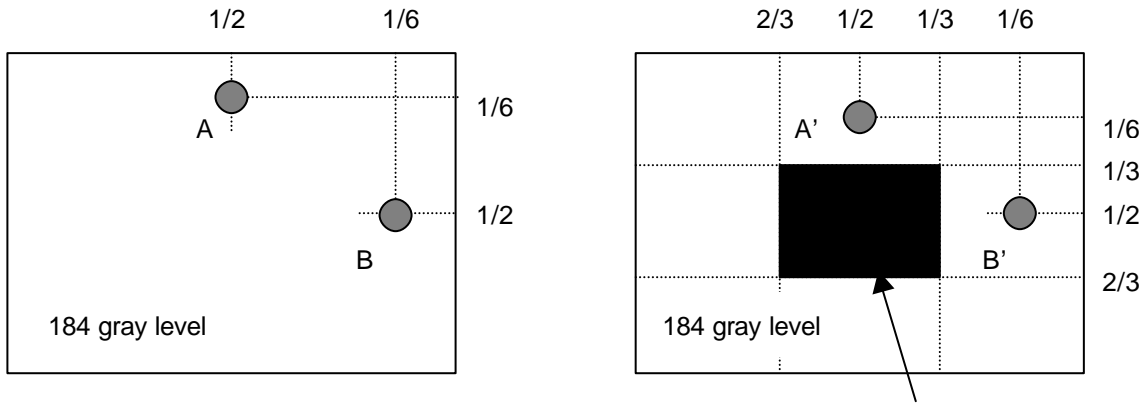

Unit: percentage of dimension of display area

$|L_A - L_{A'}| / L_A \times 100\% = 1.5\% \text{ max.}$ ,  $L_A$  and  $L_B$  are brightness at location A and B

$|L_B - L_{B'}| / L_B \times 100\% = 1.5\% \text{ max.}$ ,  $L_{A'}$  and  $L_{B'}$  are brightness at location A' and B'

**Note4:**

Test Pattern : Subchecker Pattern

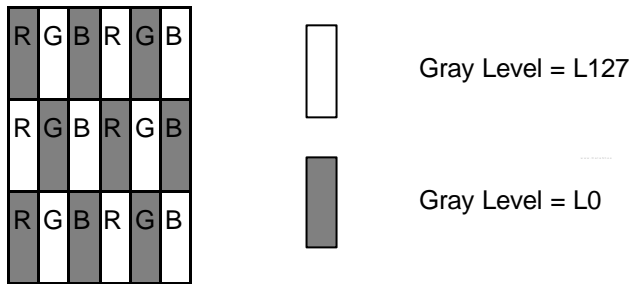

Method : Record dBV & DC value with (WESTAR)TRD-100

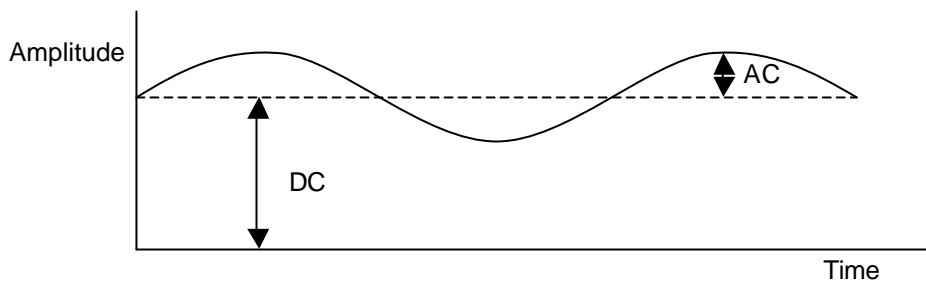

$$\text{Flicker (dB)} = 20 \log \frac{\text{AC Level(at 30 Hz)}}{\text{DC Level}}$$

### 2.4 Pixel format image

Following figure shows the relationship of the input signals and LCD pixel format.

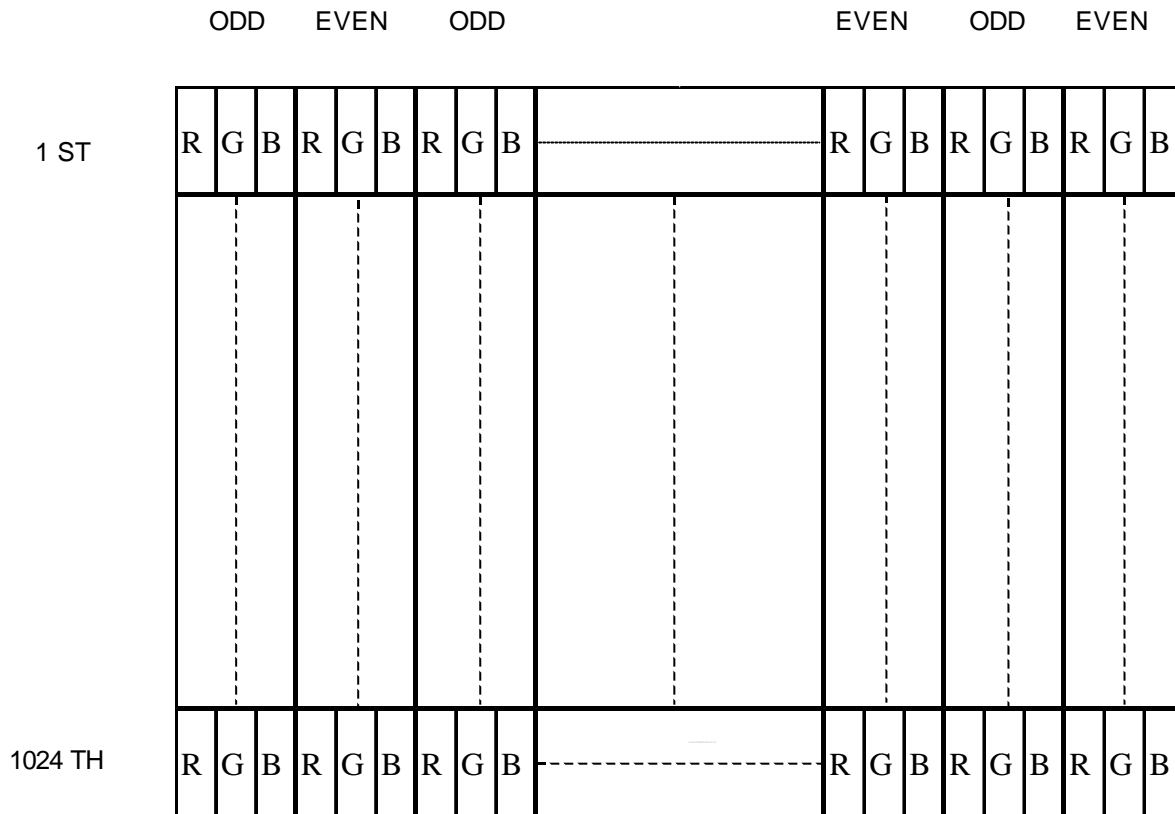

### 3.0 Electrical characteristics

#### 3.1 Absolute Maximum Ratings

Absolute maximum ratings of the module is as following:

| Item                    | Symbol | Min  | Max | Unit     | Conditions  |
|-------------------------|--------|------|-----|----------|-------------|
| Logic/LCD Drive Voltage | VIN    | -0.3 | 6   | [Volt]   |             |
| CCFL Current            | ICFL   | -    | 8.5 | [mA] rms |             |
| Operating Temperature   | TOP    | 0    | +50 | [°C]     | <b>Note</b> |
| Operating Humidity      | HOP    | 5    | 90  | [%RH]    | <b>Note</b> |
| Storage Temperature     | TST    | -20  | +60 | [°C]     | <b>Note</b> |
| Storage Humidity        | HST    | 5    | 90  | [%RH]    | <b>Note</b> |

Please refer the graph below for corresponding of Min/Max values of temperature and humidity.

**Note :** Maximum Wet-Bulb should be 39 and No condensation.

Relative Humidity %

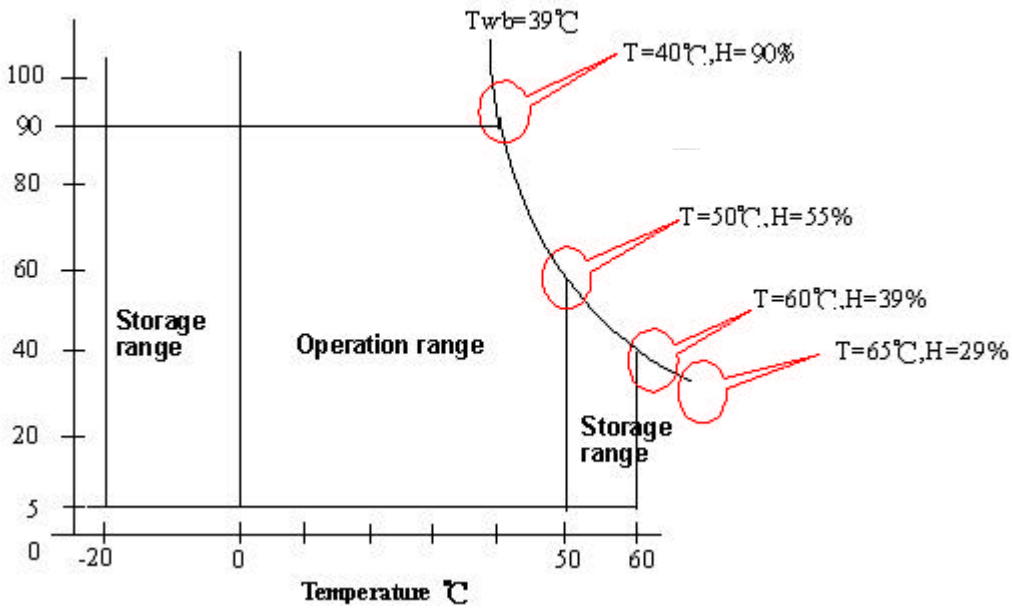

### 3.2 Connectors

Physical interface is described as for the connector on module.

These connectors are capable of accommodating the following signals and will be following components.

|                                     |                                      |
|-------------------------------------|--------------------------------------|
| <b>Connector Name / Designation</b> | Interface Connector / Interface card |
| <b>Manufacturer</b>                 | JAE or compatible                    |
| <b>Type Part Number</b>             | FI-XB30SRL-HF11 / MDF76LBRW-30S-1H   |
| <b>Mating Housing Part Number</b>   | JAE FI-X30C2L / HRS MDF76G-30P-1SD   |

|                                     |                                 |
|-------------------------------------|---------------------------------|
| <b>Connector Name / Designation</b> | Lamp Connector / Backlight lamp |
| <b>Manufacturer</b>                 | JST                             |
| <b>Type Part Number</b>             | BHSR-02VS-1                     |
| <b>Mating Type Part Number</b>      | SM02B-BHSS-1-TB                 |

### 3.3 Signal Pin

| Pin# | Signal Name | Pin# | Signal Name |
|------|-------------|------|-------------|
| 1    | RxOIN0-     | 2    | RxOIN0+     |
| 3    | RxOIN1-     | 4    | RxOIN1+     |
| 5    | RxOIN2-     | 6    | RxOIN2+     |
| 7    | VSS         | 8    | RxOCLKIN-   |
| 9    | RxOCLKIN+   | 10   | RxOIN3-     |
| 11   | RxOIN3+     | 12   | RxEIN0-     |
| 13   | RxEIN0+     | 14   | VSS         |
| 15   | RxEIN1-     | 16   | RxEIN1+     |
| 17   | VSS         | 18   | RxEIN2-     |
| 19   | RxEIN2+     | 20   | RxECLKIN-   |
| 21   | RxECLKIN+   | 22   | RxEIN3-     |
| 23   | RxEIN3+     | 24   | VSS         |
| 25   | VSS         | 26   | NC          |
| 27   | VSS         | 28   | VCC         |
| 29   | VCC         | 30   | VCC         |

### 3.4 Signal Description

The module using a pair of LVDS receiver SN75LVDS82(Texas Instruments) or compatible. LVDS is a differential signal technology for LCD interface and high speed data transfer device. Transmitter shall be SN75LVDS83(negative edge sampling) or compatible. The first LVDS port(RxOxxx) transmits odd pixels while the second LVDS port(RxExxx) transmits even pixels.

| PIN # | SIGNAL NAME | DESCRIPTION  |
|-------|-------------|--|
| 1     | RxOIN0-     | Negative LVDS differential data input (Odd data)                         |
| 2     | RxOIN0+     | Positive LVDS differential data input (Odd data)                         |
| 3     | RxOIN1-     | Negative LVDS differential data input (Odd data)                         |
| 4     | RxOIN1+     | Positive LVDS differential data input (Odd data)                         |
| 5     | RxOIN2-     | Negative LVDS differential data input (Odd data, H-Sync, V-Sync, DSPTMG) |
| 6     | RxOIN2+     | Positive LVDS differential data input (Odd data, H-Sync, V-Sync, DSPTMG) |
| 7     | VSS         | Power Ground   |
| 8     | RxOCLKIN-   | Negative LVDS differential clock input (Odd clock)                       |
| 9     | RxOCLKIN+   | Positive LVDS differential clock input (Odd clock)                       |
| 10    | RxOIN3-     | Negative LVDS differential data input (Odd data)                         |
| 11    | RxOIN3+     | Positive LVDS differential data input (Odd data)                         |
| 12    | RxEIN0-     | Negative LVDS differential data input (Even data)                        |
| 13    | RxEIN0+     | Positive LVDS differential data input (Even data)                        |
| 14    | VSS         | Power Ground   |
| 15    | RxEIN1-     | Positive LVDS differential data input (Even data)                        |
| 16    | RxEIN1+     | Negative LVDS differential data input (Even data)                        |
| 17    | VSS         | Power Ground   |
| 18    | RxEIN2-     | Negative LVDS differential data input (Even data)                        |
| 19    | RxEIN2+     | Positive LVDS differential data input (Even data)                        |
| 20    | RxECLKIN-   | Negative LVDS differential clock input (Even clock)                      |
| 21    | RxECLKIN+   | Positive LVDS differential clock input (Even clock)                      |
| 22    | RxEIN3-     | Negative LVDS differential data input (Even data)                        |
| 23    | RxEIN3+     | Positive LVDS differential data input (Even data)                        |
| 24    | VSS         | Power Ground   |
| 25    | VSS         | Power Ground   |
| 26    | NC          | No Connection ( for AUO test)  |
| 27    | VSS         | Power Ground   |
| 28    | VCC         | +5.0V Power Supply   |
| 29    | VCC         | +5.0V Power Supply   |
| 30    | VCC         | +5.0V Power Supply   |

**Note1:** Start from left side

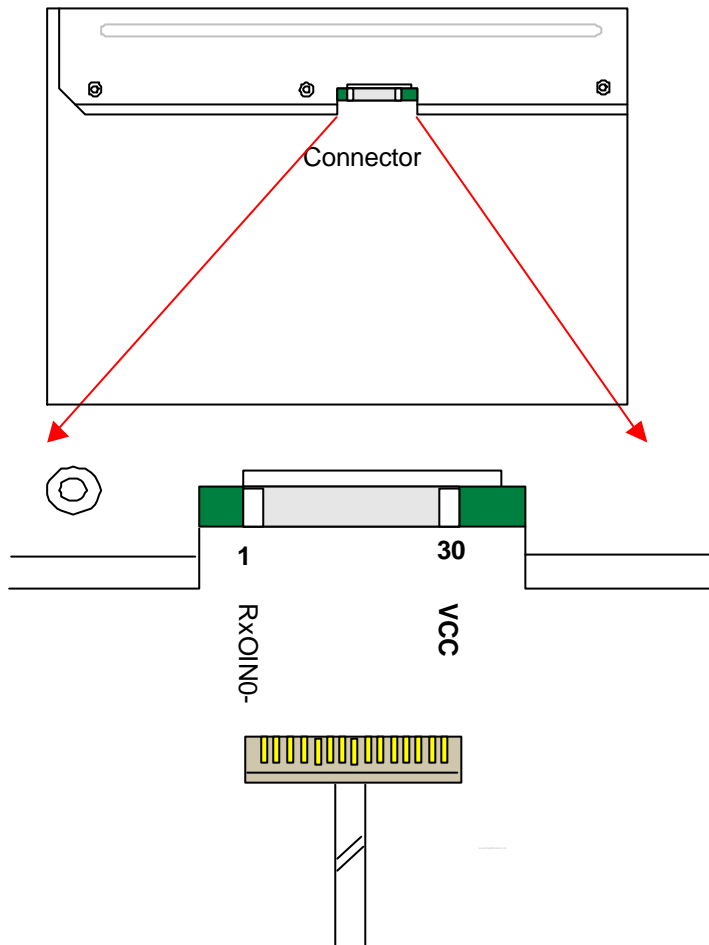

**Note2:** Input signals of odd and even clock shall be the same timing.

**Note3:** Please follow PSWG.



The input data format:

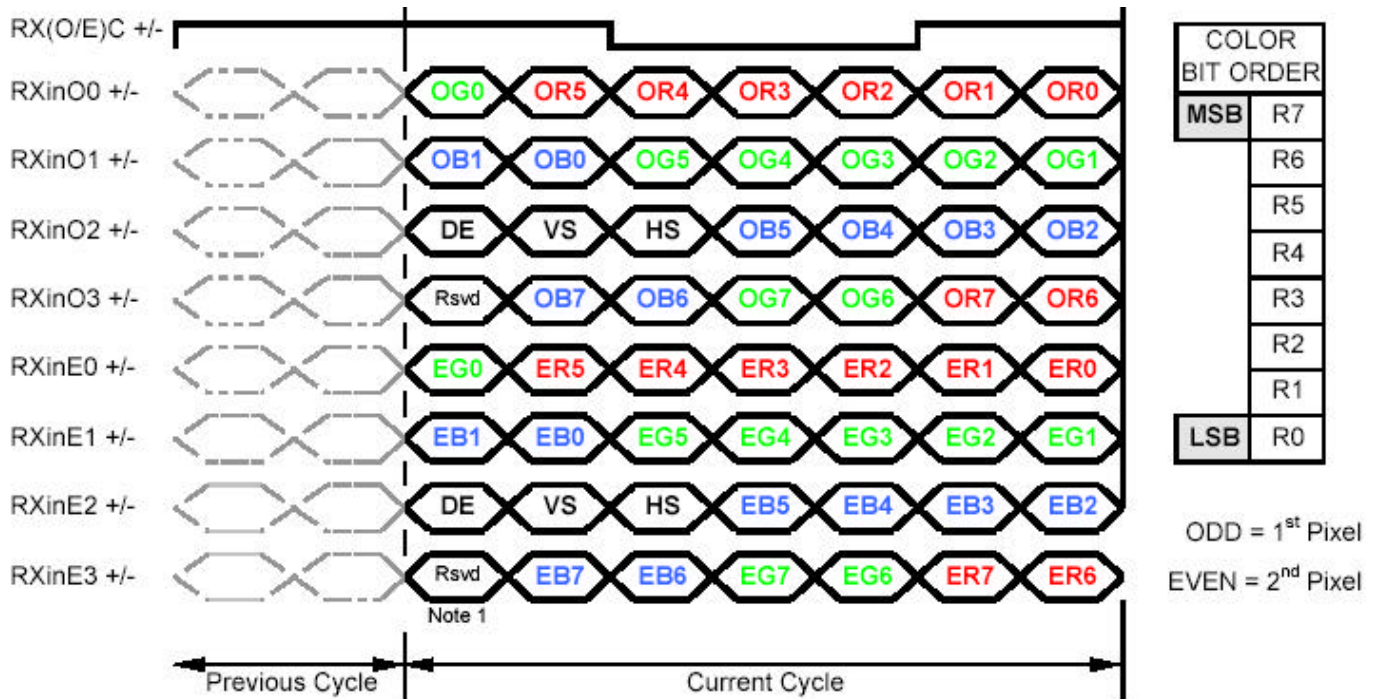

### 3.5 Signal Electrical Characteristics

Each signal characteristics are as follows;

| Symbol | Parameter                              | Min  | Typ | Max  | Units | Condition                     |
|--------|--|------|-----|------|-------|-------------------------------|
| VTH    | Differential Input High Threshold      | -    | -   | 100  | [mV]  | VICM = 1.2V <b>Note</b>       |
| VTL    | Differential Input Low Threshold       | -100 | -   | -    | [mV]  | VICM = 1.2V <b>Note</b>       |
| VID    | Input Differential Voltage             | 100  | 400 | 600  | [mV]  | <b>Note</b>                   |
| VICM   | Differential Input Common Mode Voltage | 1.1  | -   | 1.45 | [V]   | VTH/VTL = ± 100Mv <b>Note</b> |

**Note**

LVDS Signal Waveform

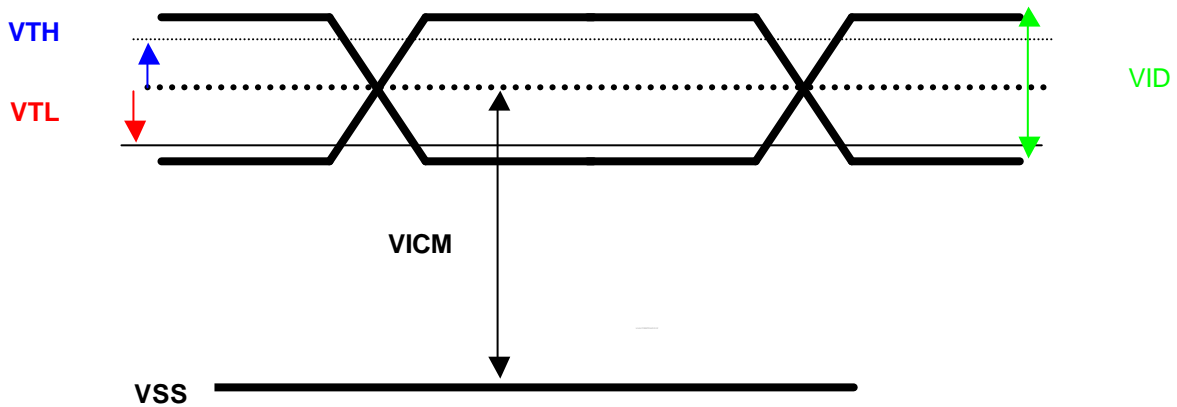

### 3.6 Interface Timings

#### 3.6.1 Timing Characteristics

| Item       | Symbol       | Min      | Typ  | Max  | Unit |
|------------|--------------|----------|------|------|------|
| Data CLK   | Tclk         | 40       | 54   | 70   | MHz  |
| H-section  | Period       | Th       | 685  | 844  | Tclk |
|            | Display Area | Tdisp(h) | 640  | 640  | Tclk |
| V-section  | Period       | Tv       | 1036 | 1066 | Th   |
|            | Display Area | Tdisp(v) | 1024 | 1024 | Th   |
| Frame Rate | F            | 49       | 60   | 76   | Hz   |

**Note:** DE mode only

### 3.6.2 Timing Definition

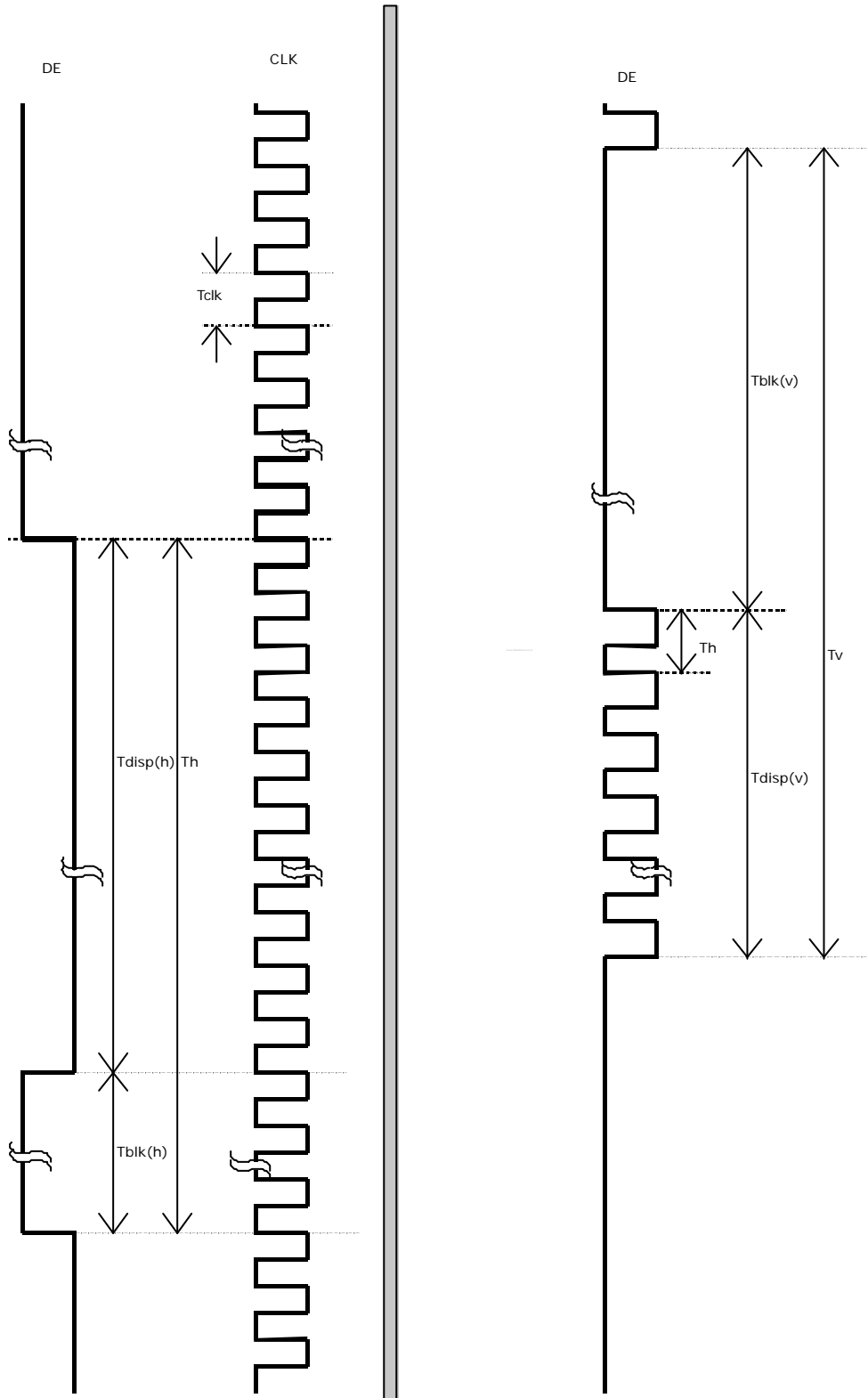

### 3.7 Power Consumption

Input power specifications are as follows;

| Symbol | Parameter                                | Min | Typ  | Max  | Units       | Condition                           |
|--------|--|-----|------|------|-------------|-------------------------------------|
| VDD    | Logic/LCD Drive Voltage                  | 4.5 | 5    | 5.5  | [Volt]      | ± 10%                               |
| IDD    | VDD current                              | -   | 1200 | 1560 | [mA]        | Vin=5V , All Black Pattern, at 75Hz |
| Irush  | LCD Inrush Current                       | -   | -    | 2.5  | [A]         | <b>Note</b>                         |
| PDD    | VDD Power                                |     | 6    | 7.8  | [Watt]      | Vin=5V , All Black Pattern, at 75Hz |
| VDDrp  | Allowable Logic/LCD Drive Ripple Voltage |     |      | 100  | [mV]<br>p-p | Vin=5V , All Black Pattern, at 75Hz |

**Note:** Measurement conditions:

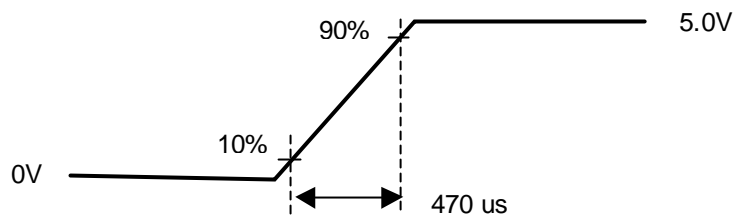
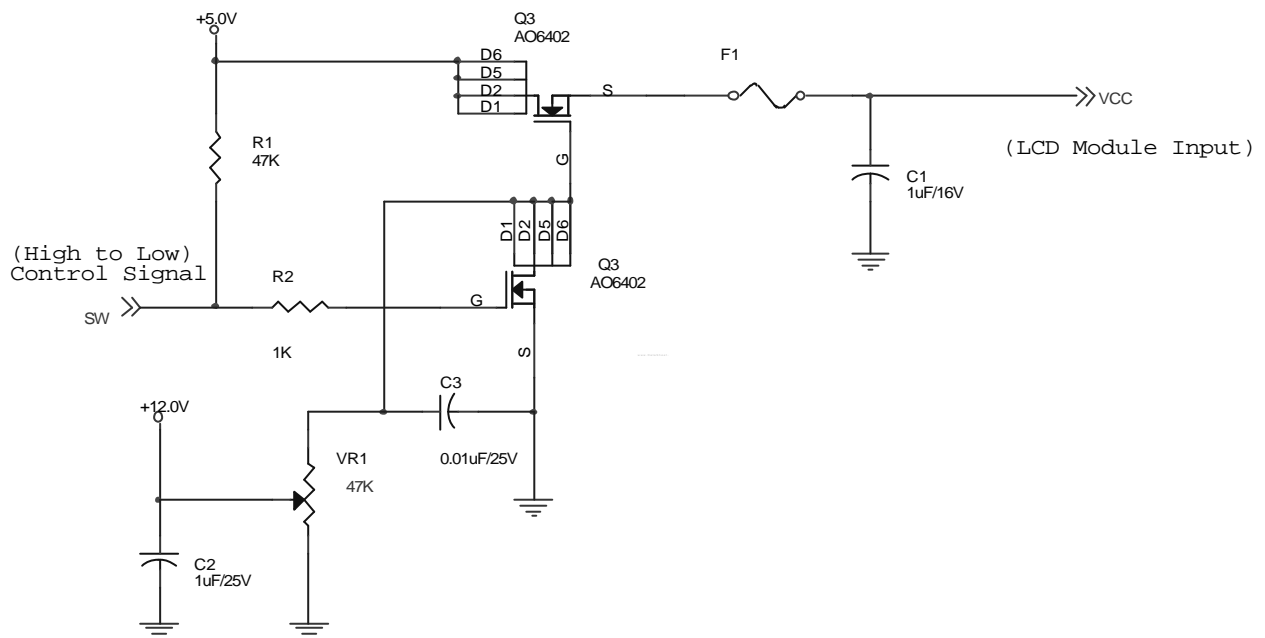

Vin rising time

### 3.8 Power ON/OFF Sequence

Vin and lamp power on/off sequence are as follows. The timing parameters of interface signal are shown in the table below. The signal please reference "3.4 Signal Description".

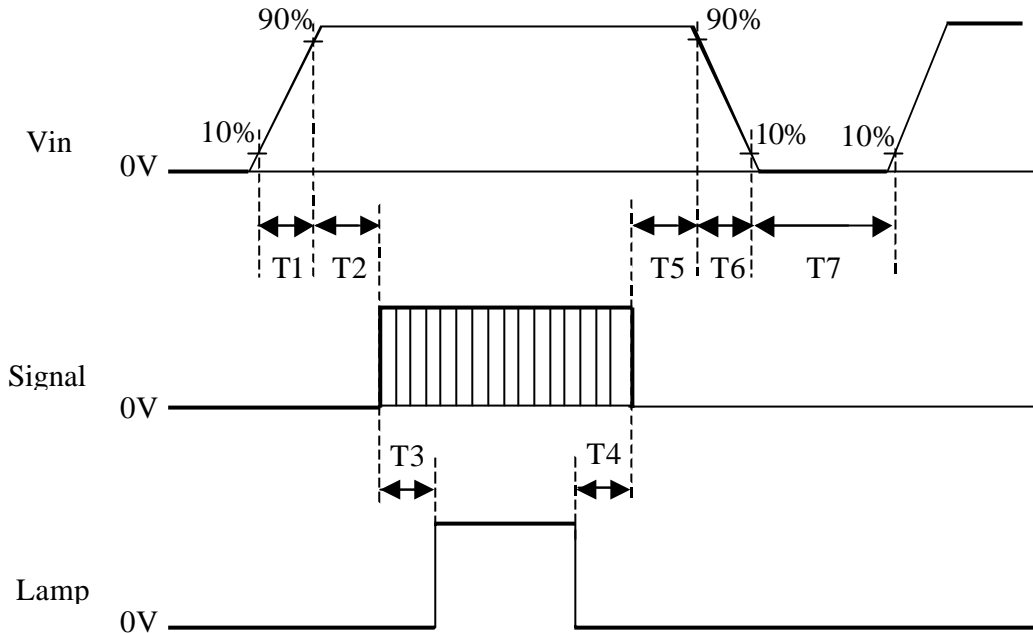

| Symbol | Values |      |      | Unit |
|--------|--------|------|------|------|
|        | Min.   | Typ. | Max. |      |
| T1     | 0.5    | -    | 10   | ms   |
| T2     | 0      | -    | 10   | ms   |
| T3     | 200    | -    | -    | ms   |
| T4     | 100    | -    | -    | ms   |
| T5     | 0      | 16   | 50   | ms   |
| T6     | -      | -    | 10   | ms   |
| T7     | 1000   | -    | -    | ms   |

**Note:** The values of the table are follow PSWG.

## 4.0 Backlight Characteristics

### 4.1 Signal for Lamp connector

|       | Connector No. | Pin No. | Input | Color | Function     |
|-------|---------------|---------|-------|-------|--------------|
| Upper | CN1           | 1       | Hot1  | Pink  | High Voltage |
|       |               | 2       | Cold1 | White | Low Voltage  |
|       | CN2           | 1       | Hot2  | Blue  | High Voltage |
|       |               | 2       | Cold2 | Black | Low Voltage  |
| Lower | CN3           | 1       | Hot1  | Pink  | High Voltage |
|       |               | 2       | Cold1 | White | Low Voltage  |
|       | CN4           | 1       | Hot2  | Blue  | High Voltage |
|       |               | 2       | Cold2 | Black | Low Voltage  |

### 4.2 Parameter guideline for CCFL Inverter

| Symbol         | Parameter   | Min.   | Typ.          | Max.          | Unit          | Condition               |
|----------------|---|--------|---------------|---------------|---------------|-------------------------|
| ISCFL          | CCFL standard current                                     | 7.0    | 7.5           | 8.0           | [mA]<br>rms   | (Ta=25°C) <b>Note 1</b> |
| IRCFL          | CCFL operation range                                      | 3.0    | 7.5           | 8.0           | [mA]<br>rms   | (Ta=25°C)               |
| FCFL           | CCFL Frequency  | 40     | 60            | 80            | [KHz]         | (Ta=25°C) <b>Note 2</b> |
| ViCFL<br>(0°C) | CCFL Ignition Voltage<br>(End of the lamp wire connector) | 1500   | -             | -             | [Volt]<br>rms | (Ta=0°C)                |
| ViCF<br>(25°C) | CCFL Ignition Voltage<br>(End of the lamp wire connector) | 1150   | -             | -             | [Volt]<br>rms | (Ta=25°C)               |
| VCFL           | CCFL Operation Voltage                                    | -      | 660<br>@7.5mA | 700<br>@3.0mA | [Volt]<br>rms | (Ta=25°C) <b>Note 1</b> |
| PCFL           | CCFL Power consumption (for reference)                    | -      | 19.8          | 21.8          | [Watt]        | (Ta=25°C) <b>Note 3</b> |
| LTCFL          | CCFL life Time  | 30,000 | 50,000        | -             | [Hour]        | (Ta=25°C) <b>Note 4</b> |

**Note 1:** CCFL standard current is measured at 25 ±2 .

**Note 2:** CCFL Frequency should be carefully determined to avoid interference between inverter and TFT LCD

**Note 3:** The variance of CCFL power consumption is ± 10%. Calculator value for reference (ICFL×VCFL×4=PCFL).

**Note 4:** CCFL life time is determined as the time at which brightness of lamp is 50%. The typical life time of CCFL is on the condition at 7.5 mA lamp current.

## 5.0 Vibration, Shock, and Drop

### 5.1 Vibration & Shock

**Vibration Test Spec:**

- Frequency: 10 - 200Hz
- Sweep: 30 Minutes each Axis (X, Y, Z)
- Acceleration: 1.5G(10~200Hz P- P)
- Test method:

|                          |           |
|--------------------------|-----------|
| <b>Acceleration (G)</b>  | 1.5       |
| <b>Frequency (Hz)</b>    | 10~200~10 |
| <b>Active time (min)</b> | 30        |

**Shock Test Spec:**

|                            |          |
|----------------------------|----------|
| <b>Acceleration (G) -a</b> | 50       |
| <b>Active time -b</b>      | 20 ms    |
| <b>Wave form</b>           | Half-sin |
| <b>Times</b>               | 1        |

- Direction:  $\pm X$ ,  $\pm Y$ ,  $\pm Z$

### 5.2 Drop test

Package test: The drop height is 60cm.

## 6.0 Environment

The display module will meet the provision of this specification during operating condition or after storage or shipment condition specified below. Operation at 10% beyond the specified range will not cause physical damage to the unit.

### 6.1 Temperature and Humidity

#### 6.1.1 Operating Conditions

The display module operates error free, when operated under the following conditions;

|                      |               |
|----------------------|---------------|
| Temperature          | 0 °C to 50 °C |
| Relative Humidity    | 8% to 95%     |
| Wet Bulb Temperature | 39.0 °C       |

#### 6.1.2 Shipping Conditions

The display module operates error free, after the following conditions;

|                      |                 |
|----------------------|-----------------|
| Temperature          | -20 °C to 60 °C |
| Relative Humidity    | 5% to 100%      |
| Wet Bulb Temperature | 39.0 °C         |





## 8.0 Safety

### 8.1 Sharp Edge Requirements

There will be no sharp edges or comers on the display assembly that could cause injury.

### 8.2 Materials

#### 8.2.1 Toxicity

There will be no carcinogenic materials used anywhere in the display module. If toxic materials are used, they will be reviewed and approved by the responsible ADT Toxicologist.

#### 8.2.2 Flammability

All components including electrical components that do not meet the flammability grade UL94-V1 in the module will complete the flammability rating exception approval process.

The printed circuit board will be made from material rated 94-V1 or better. The actual UL flammability rating will be printed on the printed circuit board.

### 8.3 Capacitors

If any polarized capacitors are used in the display assembly, provisions will be made to keep them from being inserted backwards.

## 9.0 Other requirement

### 9.1 National Test Lab Requirement

The display module will satisfy all requirements for compliance to

**UL 1950, First Edition**

**CSA C22.2 No.950-M89**

**EEC 950**

**EN 60 950**

U.S.A. Information Technology Equipment

Canada, Information Technology Equipment

International, Information Technology Equipment

International, Information Processing Equipment

(European Norm for IEC950)

### 9.2 Label

The label is on the panel as shown below:

