

TABLE 1		
DASH NUMBER	MODEL NUMBER	CENTER CONTACT/ INTERMEDIATE CONTACT TYPE
-1	5-0006 P	SOCKET/PIN
-2	5-0006 S	PIN/SOCKET

TABLE 2		
CABLE GROUP NO	CABLES ACCOMMODATED ⁶	ASSEMBLE PER
-201	M17/176-00002	TAI-162
-202	TWC-78-1, TROMPETER	
-203	TWC-124-1A, TROMPETER	
-204	10602, RAYCHEM	
-205	TWAC-78-1F2, TROMPETER	
-206	782600130, RAYCHEM	
-208	202-3927, MICRODOT	
-209	202-3942, MICRODOT	
-212	2524E0114, RAYCHEM	
-217	GC875TM24H GRUMMAN	
-218	EPD221888, RAYCHEM	
-219	2526D1114, RAYCHEM	
-220	GC875RRI, GRUMMAN	
-221	10614, RAYCHEM	
-222	10613, RAYCHEM	
-223	HMS2-1149, HUGHES	

DATA CONTAINED IN THIS DOCUMENT IS PROPRIETARY OF TROMPETER ELECTRONICS INC. AND SHALL NOT BE DISCLOSED, COPIED OR USED FOR PROCUREMENT OR MANUFACTURE WITHOUT EXPRESS WRITTEN PERMISSION.

REVISIONS

REV	DESCRIPTION	DATE	APPROVED
A	PRODUCTION RELEASE		

RED INDICATES ORIGINAL

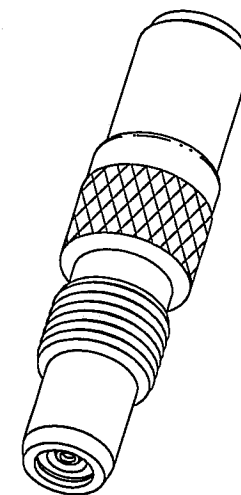

SCALE 2/1

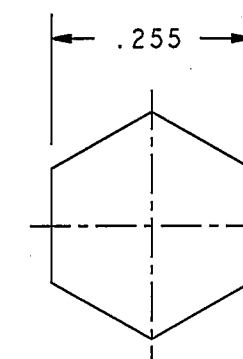
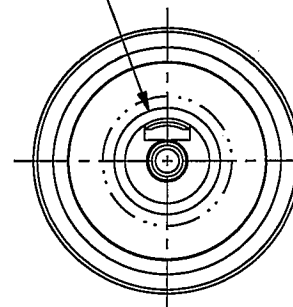
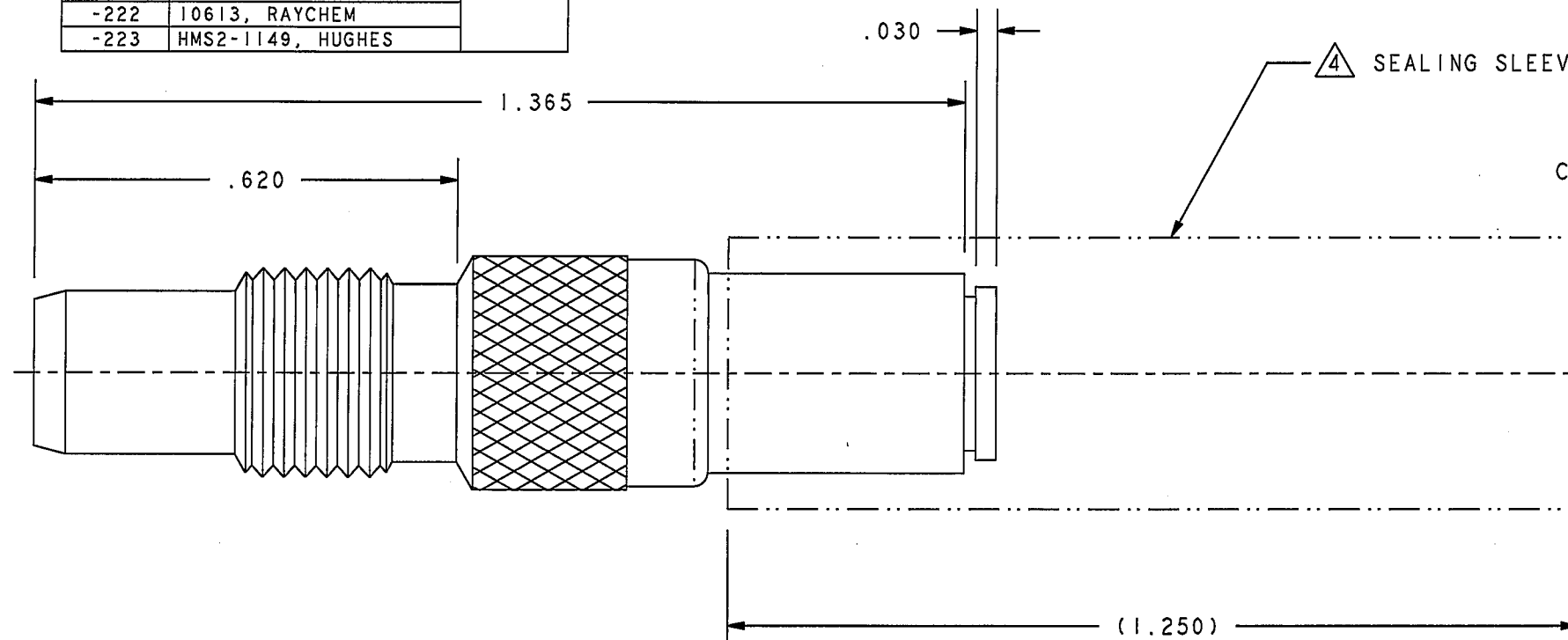
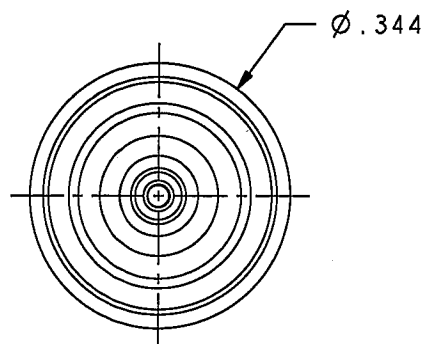

RECOMMENDED HEX CRIMP SCALE 4/1

⁶ CHECK WITH CABLE MANUFACTURER FOR OUTGASSING PROPERTIES OF THE SELECTED CABLE

5. ALL MATERIALS MEET THE OUTGASSING REQUIREMENTS OF NASA SPECIFICATION SP-R-0022A AND TEI SPACE RATED SPECIFICATION TT-09

⁴ SEALING SLEEVE AND CRIMP BUSHING TO BE SUPPLIED LOOSE WITH EACH CONNECTOR

3. EXAMPLE OF COMPLETE PART NUMBER:

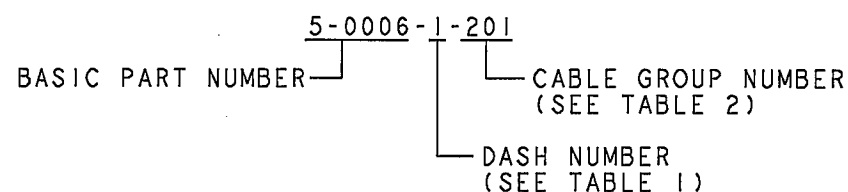

2. CONCENTRIC TWINAX 4 PIECE ASSEMBLY, FULL CRIMP NON-INSULATED BULKHEAD MOUNT RECEPTACLE, SOCKET CENTER CONTACT AND PIN INTERMEDIATE CONTACT OR PIN CENTER CONTACT AND SOCKET INTERMEDIATE CONTACT, VACUUM READY

1. FINISH: TFS-1U (NICKEL)

NOTES: UNLESS OTHERWISE SPECIFIED.

INTERPRET DRAWING PER MIL-STD-100. DIMENSIONS ARE IN INCHS AND INCLUDE FINISH THICKNESS UNLESS OTHERWISE SPECIFIED		TOL: UNLESS SPECIFIED .XX ± .02 .XXX ± .010 ANGLE ± 1°			
DRN	AAH 7-20-05	MATERIAL			
CHK	T.Kh 7-20-05	FINISH		SIZE	B
QUALITY	MS 8/4/05			CAGE CODE	14949
MANUF	JK 8-4-05	REV		SCALE	4/1
APPROVED	JM 8-4-05	DATE	8-5-05	SHEET	1C
PROVE FILE NO.	5-0006	DO NOT SCALE DWG			