



RO2180B

- **Very Low Series Resistance**
- **Quartz Stability**
- **Surface-Mount, Solder Seal Package with 4.8 x 5.2 mm Footprint**

The RO2180B is a true one-port, surface-acoustic-wave (SAW) resonator in a surface-mount ceramic case. It provides reliable, fundamental-mode, quartz frequency stabilization.

433.92 MHz SAW Resonator

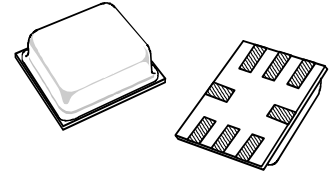

SM5248-8 Case

Absolute Maximum Ratings

Rating	Value	Units
CW RF Power Dissipation	+0	dBm
DC Voltage Between Terminals (Observe ESD Precautions)	±30	VDC
Case Temperature	-40 to +85	°C
Soldering Temperature	+250	°C

Electrical Characteristics

Characteristic		Sym	Notes	Minimum	Typical	Maximum	Units
Frequency (+25 °C)	Nominal Frequency	f_C	2, 3, 4, 5	433.845	433.92	433.995	MHz
	Tolerance from 433.92 MHz	Df_C					
Insertion Loss		IL	2, 5, 6		2		dB
Quality Factor	Unloaded Q	Q_U	5, 6, 7		11,535		
	50 Ω Loaded Q	Q_L			1,811		
Temperature Stability	Turnover Temperature	T_O	6, 7, 8		25		°C
	Turnover Frequency	f_O			f_{C+16}		
	Frequency Temperature Coefficient	FTC			0.032		ppm/°C ²
Frequency Aging	Absolute Value during the First Year	fA	1		≤10		ppm/yr
DC Insulation Resistance between Any Two Terminals			5	1.0			MΩ
RF Equivalent RLC Model	Motional Resistance	R_M	5, 6, 7, 9		18.63		Ω
	Motional Inductance	L_M			78.79		μH
	Motional Capacitance	C_M			1.71		fF
	Shunt Static Capacitance	C_O			1.82		pF
Test Fixture Shunt Inductance			L_{TEST}	2, 7		63.13	nH
Lid Symbolization (in Addition to Lot and/or Date Code)				295			



CAUTION: Electrostatic Sensitive Device. Observe precautions for handling.

Notes:

- Frequency aging is the change in f_C with time and is specified at +65°C or less. Aging may exceed the specification for prolonged temperatures above +65°C. Typically, aging is greatest the first year after manufacture, decreasing in subsequent years.
- The frequency, f_C , is measured at the minimum insertion loss point, IL_{MIN} , with the resonator in the 50 Ω test system (VSWR ≤ 1.2:1). The shunt inductance, L_{TEST} , is tuned for parallel resonance with C_O at f_C . Typically, $f_{OSCILLATOR}$ or $f_{TRANSMITTER}$ is approximately equal to the resonator f_C .
- One or more of the following United States patents apply: 4,454,488 and 4,616,197.
- Typically, equipment utilizing this device requires emissions testing and government approval, which is the responsibility of the equipment manufacturer.
- Unless noted otherwise, case temperature $T_C = +25°C ± 5°C$.
- The design, manufacturing process, and specifications of this device are subject to change without notice.
- Derived mathematically from one or more of the following directly measured parameters: f_C , IL, 3 dB bandwidth, f_C versus T_C , and C_O .
- Turnover temperature, T_O , is the temperature of maximum (or turnover) frequency, f_O . The nominal frequency at any case temperature, T_C , may be calculated from: $f = f_O [1 - FTC (T_O - T_C)^2]$. Typically, oscillator T_O is approximately equal to the specified resonator T_O .
- This equivalent RLC model approximates resonator performance near the resonant frequency and is provided for reference only. The capacitance C_O is the static (nonmotional) capacitance between the two terminals measured at low frequency (10 MHz) with a capacitance meter. The measurement includes parasitic capacitance with "NC" pads unconnected. Case parasitic capacitance is approximately 0.05 pF. Transducer parallel capacitance can be calculated as: $C_P = C_O - 0.05$ pF.

Electrical Connections

This one-port, eight-terminal solder seal resonator is bidirectional. However, impedances and circuit board parasitics may not be symmetrical, requiring slightly different oscillator component-matching values.

Pin	Connection
1	Ground
2	Input or Output
3	Ground
4	Ground
5	Ground
6	Output or Input
7	Ground
8	Ground

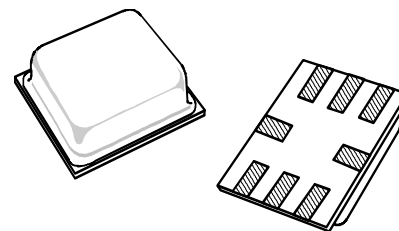

Case Design

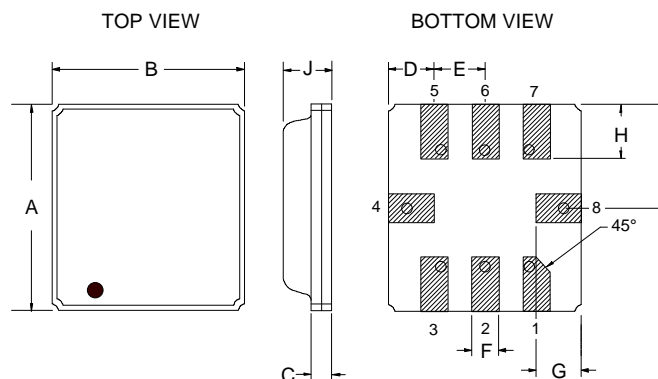

Typical Circuit

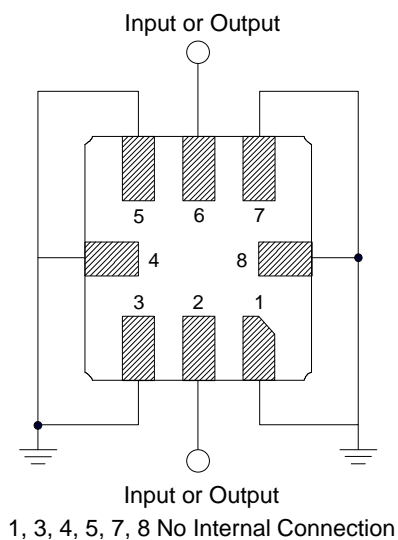

Dimensions	Millimeters			Inches		
	Min	Nom	Max	Min	Nom	Max
A	5.21	5.33	5.46	0.205	0.210	0.215
B	4.83	4.95	5.08	0.190	0.195	0.200
C	0.38	0.51	0.64	0.015	0.020	0.025
D	1.07	1.19	1.32	0.042	0.047	0.052
E	1.14	1.27	1.40	0.045	0.050	0.055
F	0.58	0.71	0.84	0.023	0.028	0.033
G	1.07	1.19	1.32	0.042	0.047	0.052
H	1.32	1.45	1.57	0.052	0.057	0.062
I	2.54	2.67	2.79	0.100	0.105	0.110
J	1.52	1.78	2.03	0.060	0.070	0.080