

3.2x2.5mm Surface Mount LVCMOS Clock Oscillator Series

CONNOR WINFIELD



Description

The Connor-Winfield's CW3xx - Series are 3.2x2.5mm Surface Mount, LVCMOS, Fixed Frequency Crystal Controlled Oscillator (XO) designed for applications requiring tight frequency stability over a wide temperature range with low jitter. Operating at 1.8V, 2.5V 2.8V or 3.3V supply voltage, the CW3xx - Series provides an LVCMOS Output with a enable / disable function.



Features:

Model Cw3xx - Series

3.2 x2.5mm Surface Mount Package
Supply Voltages Available:
1.8V, 2.5V 2.8V or 3.3V Operation
LVCMOS Output Logic
Frequency Stabilities Available:
+/-25ppm +/-50ppm or +/-100ppm
Temperature Ranges Available:
-10 to 70°C or -40 to 85°C
Low Jitter <1pS RMS
Tri-State Enable/Disable
Tape and Reel Packaging
RoHS Compliant / Lead Free

Model Specifications

Absolute Maximum Ratings

Parameter	Units	Minimum	Nominal	Maximum	UNITS	Note
Storage Temperature		-55	-	125	°C	
Supply Voltage	(Vcc)	-0.5	-	5.0	Vdc	

Operating Specifications

Parameter	Minimum	Nominal	Maximum	UNITS	Note
Frequency Range	(Fo)	1.8	-	75	MHz
Total Frequency Tolerance					
Models CW3x1	-25	-	25	ppm	1
Models CW3x2	-50	-	50	ppm	1
Models CW3x3	-100	-	100	ppm	1
Operating Temperature Range					
Models CW31x, CW32x, CW33x, CW34x	-10	-	70	°C	
Models CW35x, CW36x, CW37x, CW38x	-40	-	85	°C	
Supply Voltage (Vcc)					
Models CW32x, CW36x	1.710	1.800	1.890	Vdc	
Models CW32x, CW36x	2.375	2.500	2.625	Vdc	
Models CW34x, CW38x	2.660	2.800	2.940	Vdc	
Models CW33x, CW37x	3.135	3.300	3.465	Vdc	
Supply Current (Icc)					
1.8V Models	-	-	10	mA	
2.5V, 2.8V, 3.3V Models	-	-	20	mA	

Input Characteristics

Parameter	Minimum	Nominal	Maximum	Units	Note
Enable Voltage (High) (Vih)	0.9Vcc	-	-	Vdc	2
Disable Voltage (Low) (Vil)	-	-	0.1Vcc	Vdc	2
Enable Time	-	-	2	ms	
Disable Time	-	-	200	ns	
Output Disable Current (Standby Current) (Icc)	-	-	10	uA	

LVCMOS Output Characteristics

Parameter	Minimum	Nominal	Maximum	Units	Note
LOAD	-	-	15	pF	
Voltage (High) (Voh)	0.9Vcc	-	-	Vdc	
(Low) (Vol)	-	-	0.1Vcc	Vdc	
Current (High) (Ioh)	-8	-	-	mA	
(Low) (Iol)	-	-	8	mA	
Duty Cycle at 50% of Vcc	45	50	55	%	
Rise / Fall Time 10% to 90%	-	5	8	ns	
Start-Up Time	-	2	5	ms	
Period Jitter	-	3	5	ps RMS	
Phase Jitter (BW=12kHz to 20MHz)	-	0.5	1	ps RMS	
SSB Phase Noise at 10Hz offset	-	-60	-	dBc/Hz	
SSB Phase Noise at 100Hz offset	-	-90	-	dBc/Hz	
SSB Phase Noise at 1KHz offset	-	-125	-	dBc/Hz	
SSB Phase Noise at 10KHz offset	-	-140	-	dBc/Hz	
SSB Phase Noise at 100KHz offset	-	-145	-	dBc/Hz	

Package Characteristics

Package	Hermetically sealed ceramic package and grounded metal cover.
Soldering Process	RoHS compliant, see solder profile on page 2.

Specifications subject to change without notice. All dimensions in inches. © Copyright 2008 The Connor-Winfield Corporation

2111 Comprehensive Drive

Aurora, Illinois 60505

Phone: 630-851-4722

Fax: 630-851-5040

www.conwin.com

US Headquarters:

630-851-4722

European Headquarters:

+353-61-472221



Bulletin **Sm128**

Page **1 of 2**

Revision **01**

Date **18 May 2010**



Notes

- Inclusive of calibration @ 25°C, frequency vs. temperature stability, supply voltage change, load change, shock and vibration, 10 years aging.
- When the oscillator is disabled, the outputs are at high impedance. Output is enabled with no connection on pad 1.

Ordering Information

CW3	3	3	- 044.736M
Type: 3.2x2.5mm LVCMOS Clock Oscillator Series	Supply Voltage and Temperature Range: 1 = 1.8V, -10 to 70° C 2 = 2.5V, -10 to 70° C 3 = 3.3V, -10 to 70° C 4 = 2.8V, -10 to 70° C 5 = 1.8V, -40 to 85° C 6 = 2.5V, -40 to 85° C 7 = 3.3V, -40 to 85° C 8 = 2.8V, -40 to 85° C	Frequency Stability: 1 = +/-25 ppm 2 = +/-50 ppm 3 = +/-100 ppm	Output Frequency: Frequency Format -xxx.xM Min.* -xxx.xxxxxM Max.* *Amount of numbers after the decimal point. M = MHz

Example: CW333-044.376M = 3.2x2.5mm, LVCMOS Clock, -10 to 70° C, +/-100ppm, 3.3Vdc, Output Frequency 44.736MHz

To order an CW333 with an output frequency of:
 1.8 MHz = CW333-001.8M
 50.0 MHz = CW333-050.0M
 74.25 MHz = CW333-074.25M

Environmental Characteristics

Vibration:	Vibration per Mil Std 883E Method 2007.3 Test Condition A
Shock:	Mechanical Shock per Mil Std 883E Method 2002.4 Test Condition B.
Soldering:	RoHS compliant, lead free. See solder profile.
Solderability:	Solderability per Mil Std 883E Method 2003

Pad Connections - Enable / Disable Function

Pad	Connection	Enable / Disable Function (Pad 1)	Output
1	Enable/Disable	High or Open	Enable
2	Ground	Low	Disable (High Impedance)
3	Output		
4	Vcc		

Model Matrix

Frequency Tolerance ±25ppm	Frequency Tolerance ±50ppm	Frequency Tolerance ±100ppm	Supply Voltage	Temperature Range
CW311	CW312	CW313	1.8Vdc	-10 to 70°C
CW321	CW322	CW323	2.5Vdc	-10 to 70°C
CW341	CW342	CW343	2.8Vdc	-10 to 70°C
CW331	CW332	CW333	3.3Vdc	-10 to 70°C
CW351	CW352	CW353	1.8Vdc	-40 to 85°C
CW361	CW362	CW363	2.5Vdc	-40 to 85°C
CW381	CW382	CW383	2.8Vdc	-40 to 85°C
CW371	CW372	CW373	3.3Vdc	-40 to 85°C

Tape and Reel Specifications

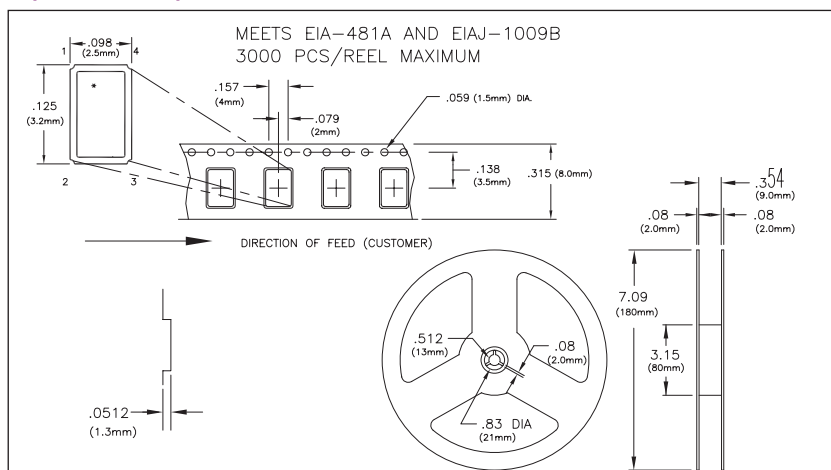

Package Outline

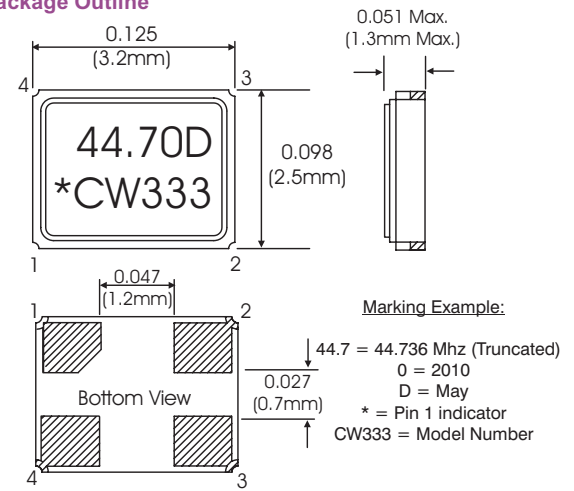

Marking drawing 90231DWG74

Suggested Pad Layout

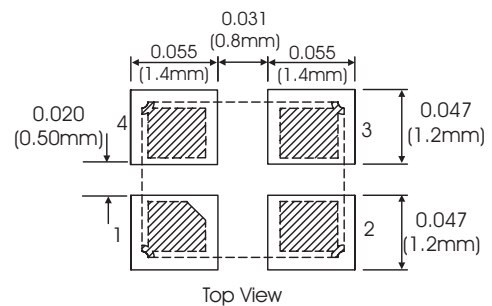

Solder Profile

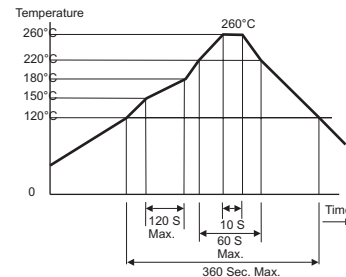

LVCMOS Output Waveform

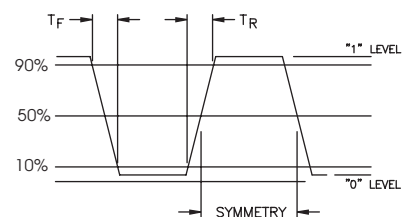

US Headquarters:
 630-851-4722
 European Headquarters:
 +353-61-472221

Bulletin	SM128
Page	2 of 2
Revision	01
Date	18 May 2010