

Ultrafast Recovery Modules HU20130 — HU20150

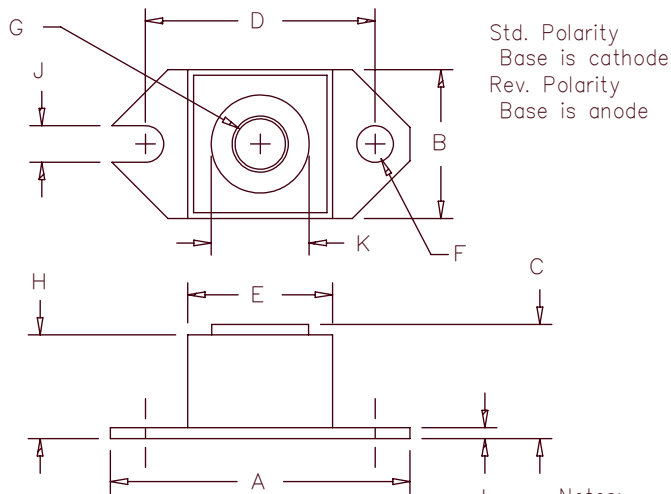

Std. Polarity
Base is cathode
Rev. Polarity
Base is anode

Dim.	Inches		Millimeter		Notes
	Minimum	Maximum	Minimum	Maximum	
A	1.52	1.56	38.61	39.62	
B	.725	.775	18.42	19.69	
C	.605	.625	15.37	15.88	
D	1.182	1.192	30.02	30.28	
E	.745	.755	18.92	19.18	Sq.
F	.152	.160	3.86	4.06	Dia.
G		1/4-20	UNC-2B		
H	.525	.580	13.34	14.73	
J	.156	.160	3.96	4.06	
K	.495	.505	12.57	12.83	Dia.
L	.120	.130	3.05	3.30	

Notes:
Baseplate: Nickel plated
copper

Microsemi Catalog Number	Working Peak Reverse Voltage	Repetitive Peak Reverse Voltage
HU20130*	300V	300V
HU20140*	400V	400V
HU20150*	500V	500V

*Add Suffix R for Reverse Polarity

- Ultra Fast Recovery
- 175°C Junction Temperature
- 200 Amp current rating
- ROHS Compliant

Electrical Characteristics

Average forward current	$I_F(AV)$ 200 Amps	$T_C = 126^\circ\text{C}$, Square wave, $R_{\theta JC} = 0.24^\circ\text{C/W}$
Maximum surge current	I_{FSM} 2500 Amps	8.3ms, half sine, $T_J = 175^\circ\text{C}$
Max peak forward voltage	V_{FM} 1.25 Volts	$I_{FM} = 200\text{A}; T_J = 25^\circ\text{C}^*$
Max peak reverse recovery time	t_{rr} 110 nS	$I_F = 1\text{A}, V_R = 30\text{V di/dt} = 25\text{A}/\mu\text{S}$
Max peak reverse current	I_{RM} 8 mA	$V_{RRM}, T_J = 125^\circ\text{C}^*$
Max peak reverse current	I_{RM} 50 uA	$V_{RRM}, T_J = 25^\circ\text{C}$
Typical junction capacitance	C_J 500 pF	$V_R = 10\text{V}, T_J = 25^\circ\text{C}$

*Pulse test: Pulse width 300 μsec , Duty cycle 2%

Thermal and Mechanical Characteristics

Storage temp range	T_{STG}	-55°C to 175°C
Operating junction temp range	T_J	-55°C to 175°C
Max thermal resistance	$R_{\theta JC}$	0.24°C/W Junction to case
Typical thermal resistance (greased)	$R_{\theta CS}$	0.12°C/W Case to sink
Terminal Torque		35-40 inch pounds
Mounting Base Torque (outside holes)		20-25 inch pounds
Weight		1.1 ounces (32 grams) typical

HU20130 — HU20150

Figure 1
Typical Forward Characteristics

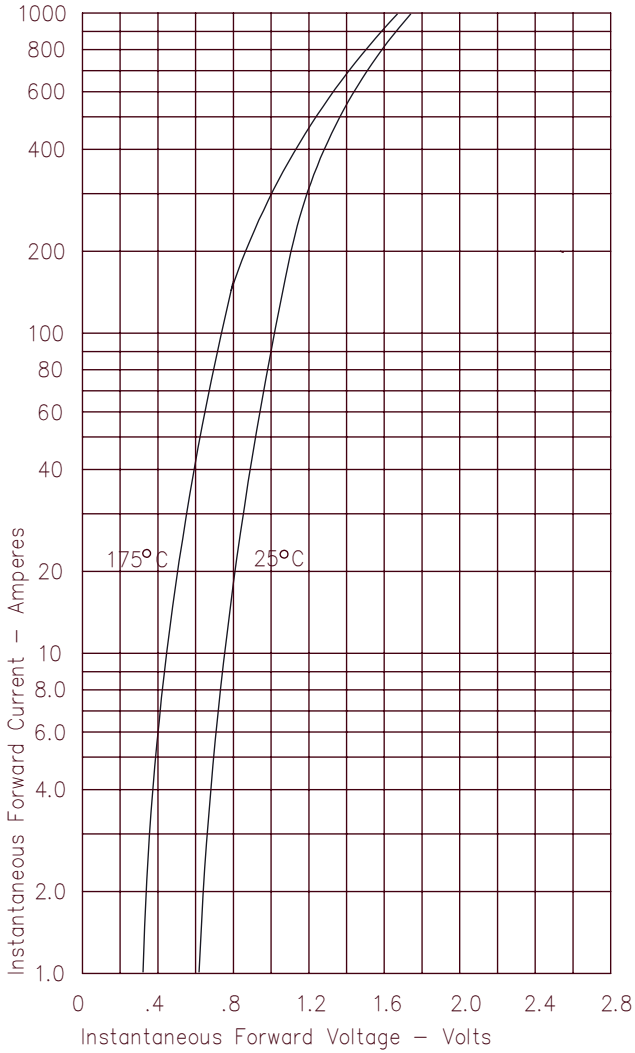

Figure 3
Typical Junction Capacitance

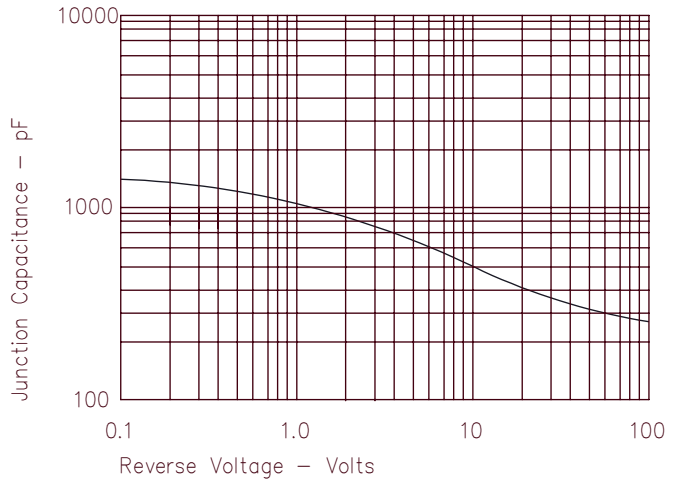

Figure 4
Forward Current Derating

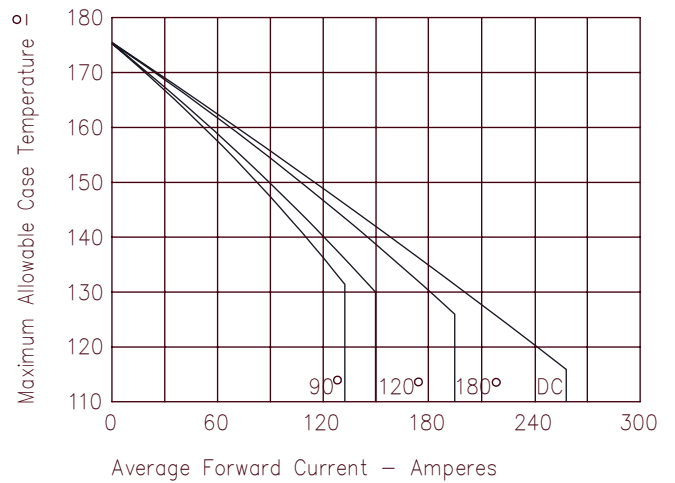

Figure 2
Typical Reverse Characteristics

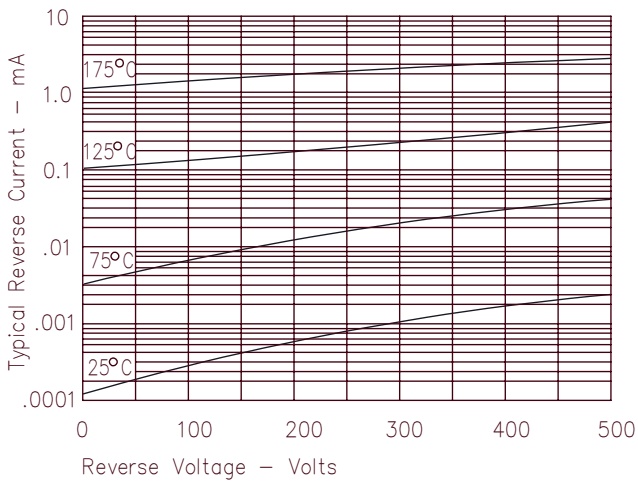

Figure 5
Maximum Forward Power Dissipation

