

# Chip Inductor (Chip Coil) Power Inductor (Wire Wound Type)

## LQH2HP\_G0 Series (1008 Size)

### ■ Dimensions

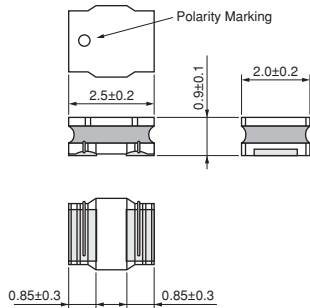

(in mm)

### ■ Packaging

Code	Packaging	Minimum Quantity
L	180mm Embossed Tape	3000

### ■ Rated Value (□: packaging code)

Part Number	Inductance	Rated Current (Based on Inductance Change)	Rated Current (Based on Temperature Rise)	DC Resistance	Self Resonance Frequency (min.)
LQH2HPN2R2MG0□	2.2μH ±20%	1640mA	1000mA	0.17ohm ±20%	80MHz
LQH2HPN3R3MG0□	3.3μH ±20%	1290mA	810mA	0.27ohm ±20%	65MHz
LQH2HPN4R7MG0□	4.7μH ±20%	1000mA	700mA	0.36ohm ±20%	60MHz
LQH2HPN6R8MG0□	6.8μH ±20%	800mA	590mA	0.5ohm ±20%	10MHz
LQH2HPN100MG0□	10μH ±20%	700mA	490mA	0.73ohm ±20%	10MHz
LQH2HPN220MG0□	22μH ±20%	490mA	340mA	1.6ohm ±20%	10MHz
LQH2HPN101MG0□	100μH ±20%	210mA	130mA	10ohm ±20%	5MHz

Test Frequency: 1MHz Class of Magnetic Shield: Magnetic shield of magnetic powder in resin  
 Operating Temperature Range (Self-temperature rise is not included): -40 to +85°C  
 Only for reflow soldering.

### ■ Notice (Rated Current)

Inductance will be more than the value which is 30% down from minimum rated Inductance value.  
 When Rated Current is applied to the Products, self-generation of heat will rise to 40°C or less.

Continued on the following page.

● This data sheet is applied for CHIP INDUCTORS (CHIP COILS) used for General Electronics equipment for your design.

### ⚠ Note:

- This datasheet is downloaded from the website of Murata Manufacturing co., ltd. Therefore, it's specifications are subject to change or our products in it may be discontinued without advance notice. Please check with our sales representatives or product engineers before ordering.
- This datasheet has only typical specifications because there is no space for detailed specifications. Therefore, please approve our product specifications or transact the approval sheet for product specifications before ordering.

Continued from the preceding page.

### Inductance-Frequency Characteristics (Typ.)

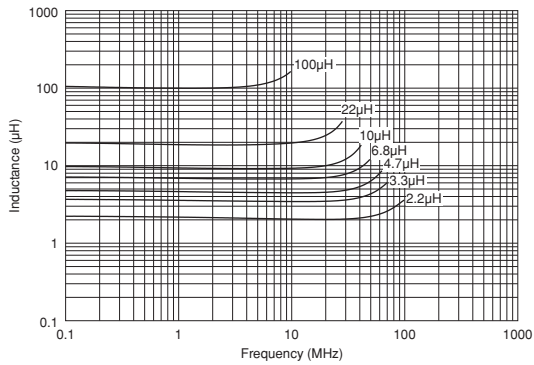

### Inductance-Current Characteristics (Typ.)

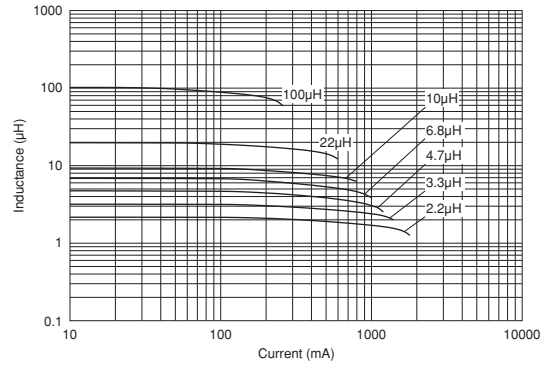

### Temperature Rise Characteristics (Typ.)

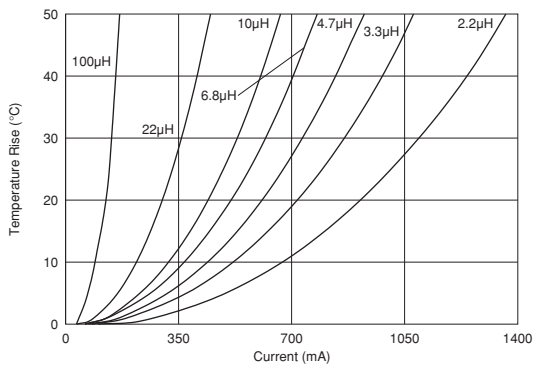

### Caution/Notice

#### Caution (Rating)

Do not use products beyond the rated current as this may create excessive heat.

#### Notice

Solderability of Tin plating termination chip might be deteriorated when low temperature soldering profile where peak solder temperature is below the Tin melting point is used. Please confirm the solderability of Tin plating termination chip before use.

● This data sheet is applied for CHIP INDUCTORS (CHIP COILS) used for General Electronics equipment for your design.

#### Note:

1. This datasheet is downloaded from the website of Murata Manufacturing Co., Ltd. Therefore, its specifications are subject to change or our products in it may be discontinued without advance notice. Please check with our sales representatives or product engineers before ordering.
2. This datasheet has only typical specifications because there is no space for detailed specifications. Therefore, please approve our product specifications or transact the approval sheet for product specifications before ordering.