

# R1EX25008ASA00G/R1EX25008ATA00G R1EX25016ASA00G/R1EX25016ATA00G

Serial Peripheral Interface

8k EEPROM (1024-word × 8-bit)

16k EEPROM (2048-word × 8-bit)

## 105°C SPI-bus EEPROM

R10DS0083EJ0100

Rev.1.00

Oct. 02, 2012

### Description

R1EX25xxx series is the Serial Peripheral Interface compatible (SPI) EEPROM (Electrically Erasable and Programmable ROM). R1EX25xxxG series improves the write/erase endurance in addition to suitable for the high temperature industrial application that makes the best use of the feature of advanced MONOS memory cell structure.

### Features

- Single supply: 1.8 V to 5.5 V
- Serial Peripheral Interface compatible (SPI bus)
  - SPI mode 0 (0,0), 3 (1,1)
- Clock frequency: 5 MHz (2.5 V to 5.5 V), 3 MHz (1.8 V to 5.5 V)
- Power dissipation:
  - Standby: 2 μA (max)
  - Active (Read): 2.5 mA (max)
  - Active (Write): 3 mA (max)
- Automatic page write: 32-byte/page
- Write cycle time: 5 ms
- Endurance: 1,000k Cycles @85°C / 200k Cycles @105°C
- Data retention: 20 Years
- Small size packages: SOP-8pin, TSSOP-8pin
- Shipping tape and reel
  - TSSOP 8-pin: 3,000 IC/reel
  - SOP 8-pin: 2,500 IC/reel
- Temperature range: -40 to +105°C
- Lead free products.
- Halogen free products.

## Ordering Information

Orderable Part Numbers	Internal organization	Package	Shipping tape and reel
R1EX25008ASA00G#U0	8k bit (1024 × 8-bit)	150 mil 8-pin plastic SOP PRSP0008DF-B (FP-8DBV) Lead free, Halogen free	2,500 IC/reel
R1EX25016ASA00G#U0	16k bit (2048 × 8-bit)		
R1EX25008ATA00G#U0	8k bit (1024 × 8-bit)	8-pin plastic TSSOP PTSP0008JC-B (TTP-8DAV) Lead free, Halogen free	3,000 IC/reel
R1EX25016ATA00G#U0	16k bit (2048 × 8-bit)		

## Pin Arrangement

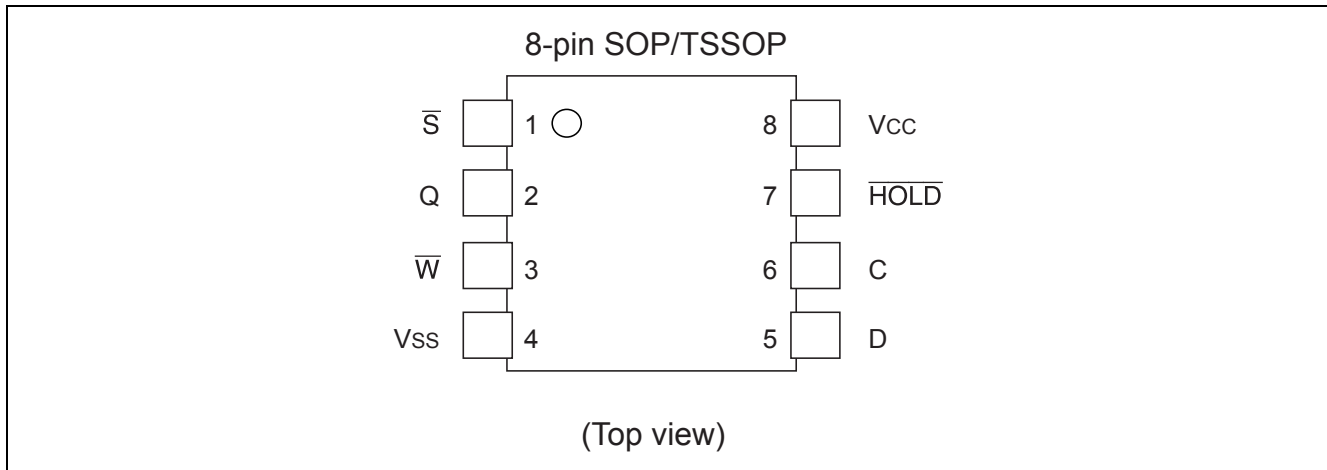

## Pin Description

Pin name	Function
C	Serial clock
D	Serial data input
Q	Serial data output
S	Chip select
W	Write protect
HOLD	Hold
V <sub>CC</sub>	Supply voltage
V <sub>SS</sub>	Ground

## Block Diagram

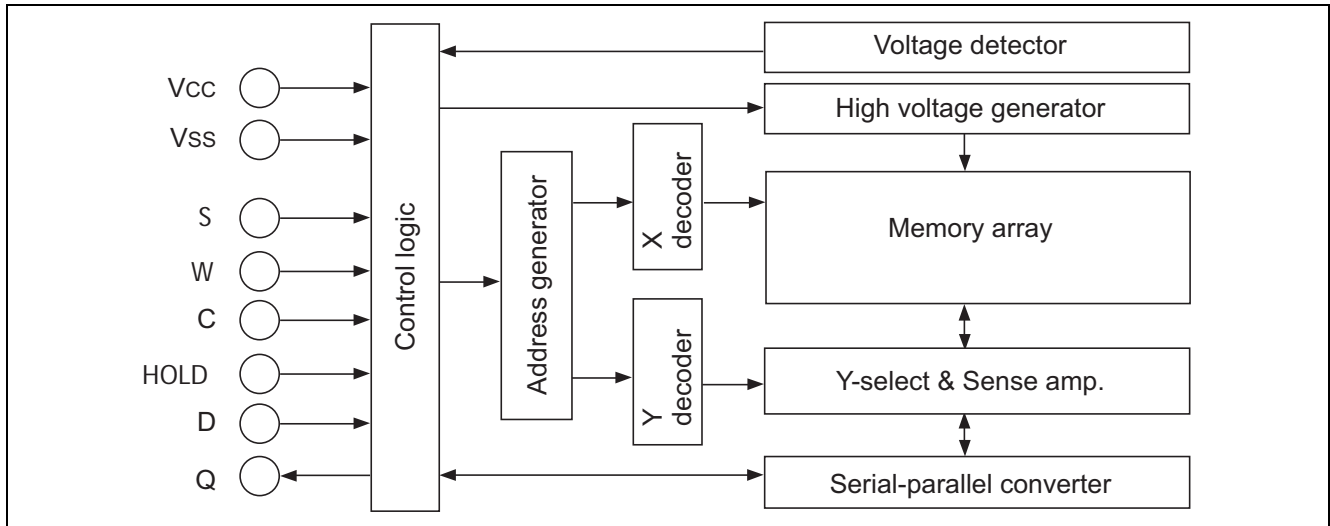

## Absolute Maximum Ratings

Parameter	Symbol	Value	Unit
Supply voltage relative to V <sub>SS</sub>	V <sub>CC</sub>	-0.6 to +7.0	V
Input voltage relative to V <sub>SS</sub>	V <sub>IN</sub>	-0.5* <sup>2</sup> to +7.0* <sup>3</sup>	V
Operating temperature range* <sup>1</sup>	T <sub>opr</sub>	-40 to +105	°C
Storage temperature range	T <sub>stg</sub>	-55 to +125	°C

Notes: 1. Including electrical characteristics and data retention.

2. V<sub>IN</sub> (min): -3.0 V for pulse width ≤ 50 ns.

## DC Operating Conditions

Parameter	Symbol	Min	Typ	Max	Unit
Supply voltage	V <sub>CC</sub>	1.8	—	5.5	V
	V <sub>SS</sub>	0	0	0	V
Input voltage	V <sub>IH</sub>	V <sub>CC</sub> × 0.7	—	V <sub>CC</sub> + 0.5* <sup>2</sup>	V
	V <sub>IL</sub>	-0.3* <sup>1</sup>	—	V <sub>CC</sub> × 0.3	V
Operating temperature range	T <sub>opr</sub>	-40	—	+105	°C

Notes: 1. V<sub>IN</sub> (min): -1.0 V for pulse width ≤ 50 ns.

2. V<sub>IN</sub> (max): V<sub>CC</sub> + 1.0 V for pulse width ≤ 50 ns.

## Capacitance

(T<sub>a</sub> = +25°C, f = 1 MHz)

Parameter	Symbol	Min	Typ	Max	Unit	Test conditions
Input capacitance (D, C, S, W, HOLD)	C <sub>in</sub> * <sup>1</sup>	—	—	6.0	pF	V <sub>in</sub> = 0 V
Output capacitance (Q)	C <sub>I/O</sub> * <sup>1</sup>	—	—	8.0	pF	V <sub>out</sub> = 0 V

Note: 1. Not 100% tested.

## Memory cell characteristics

(V<sub>CC</sub> = 1.8 V to 5.5 V)

	T <sub>a</sub> =85°C	T <sub>a</sub> =105°C	Notes
Endurance	1,000k Cycles min.	200k Cycles min.	1
Data retention	20 Years min.	20 Years min.	1

Note: 1. Not 100% tested.

## DC Characteristics

Parameter		Symbol	Min	Typ	Max	Unit	Test conditions
Input leakage current		$I_{LI}$	—	—	2	$\mu\text{A}$	$V_{CC} = 5.5\text{ V}$ , $V_{IN} = 0$ to $5.5\text{ V}$ (S, D, C, HOLD, W)
Output leakage current		$I_{LO}$	—	—	2	$\mu\text{A}$	$V_{CC} = 5.5\text{ V}$ , $V_{OUT} = 0$ to $5.5\text{ V}$ (Q)
$V_{CC}$ current	Standby	$I_{SB}$	—	0.5	—	$\mu\text{A}$	$V_{IN} = V_{SS}$ or $V_{CC}$ , $V_{CC} = 3.6\text{ V}$
			—	—	2	$\mu\text{A}$	$V_{IN} = V_{SS}$ or $V_{CC}$ , $V_{CC} = 5.5\text{ V}$
	Active	$I_{CC1}$	—	0.7	2	$\text{mA}$	$V_{CC} = 3.6\text{ V}$ , Read at $5\text{ MHz}$ $V_{IN} = V_{CC} \times 0.1/V_{CC} \times 0.9$ Q = OPEN
			—	—	2.5	$\text{mA}$	$V_{CC} = 5.5\text{ V}$ , Read at $5\text{ MHz}$ $V_{IN} = V_{CC} \times 0.1/V_{CC} \times 0.9$ Q = OPEN
		$I_{CC2}$	—	1.2	2	$\text{mA}$	$V_{CC} = 3.6\text{ V}$ , Write at $5\text{ MHz}$ $V_{IN} = V_{CC} \times 0.1/V_{CC} \times 0.9$
			—	—	3	$\text{mA}$	$V_{CC} = 5.5\text{ V}$ , Write at $5\text{ MHz}$ $V_{IN} = V_{CC} \times 0.1/V_{CC} \times 0.9$
Output voltage		$V_{OL1}$	—	—	0.4	V	$V_{CC} = 5.5\text{ V}$ , $I_{OL} = 2\text{ mA}$
		$V_{OL2}$	—	—	0.4	V	$V_{CC} = 2.5\text{ V}$ , $I_{OL} = 1.5\text{ mA}$
		$V_{OH1}$	$V_{CC} \times 0.8$	—	—	V	$V_{CC} = 5.5\text{ V}$ , $I_{OH} = -2\text{ mA}$
		$V_{OH2}$	$V_{CC} \times 0.8$	—	—	V	$V_{CC} = 2.5\text{ V}$ , $I_{OH} = -0.4\text{ mA}$

## AC Characteristics

### Test Conditions

- Input pulses levels:
  - $V_{IL} = V_{CC} \times 0.2$
  - $V_{IH} = V_{CC} \times 0.8$
- Input rise and fall time:  $\leq 10$  ns
- Input and output timing reference levels:  $V_{CC} \times 0.3, V_{CC} \times 0.7$
- Output reference levels:  $V_{CC} \times 0.5$
- Output load: 100 pF

( $T_a = -40$  to  $+105^\circ\text{C}$ ,  $V_{CC} = 2.5$  V to 5.5 V)

Parameter	Symbol	Alt	Min	Max	Unit	Notes
Clock frequency	$f_C$	$f_{SCK}$	—	5	MHz	
S active setup time	$t_{SLCH}$	$t_{CSS1}$	90	—	ns	
S not active setup time	$t_{SHCH}$	$t_{CSS2}$	90	—	ns	
S deselect time	$t_{SHSL}$	$t_{CS}$	90	—	ns	
S active hold time	$t_{CHSH}$	$t_{CSH}$	90	—	ns	
S not active hold time	$t_{CHSL}$	—	90	—	ns	
Clock high time	$t_{CH}$	$t_{CLH}$	90	—	ns	1
Clock low time	$t_{CL}$	$t_{CLL}$	90	—	ns	1
Clock rise time	$t_{CLCH}$	$t_{RC}$	—	1	$\mu\text{s}$	2
Clock fall time	$t_{CHCL}$	$t_{FC}$	—	1	$\mu\text{s}$	2
Data in setup time	$t_{DVCH}$	$t_{DSU}$	20	—	ns	
Data in hold time	$t_{CHDX}$	$t_{DH}$	30	—	ns	
Clock low hold time after HOLD not active	$t_{HHCH}$	—	70	—	ns	
Clock low hold time after HOLD active	$t_{HLCH}$	—	40	—	ns	
Clock high setup time before HOLD active	$t_{CHHL}$	—	60	—	ns	
Clock high setup time before HOLD not active	$t_{CHHH}$	—	60	—	ns	
Output disable time	$t_{SHQZ}$	$t_{DIS}$	—	100	ns	2
Clock low to output valid	$t_{CLQV}$	$t_V$	—	70	ns	
Output hold time	$t_{CLQX}$	$t_{HO}$	0	—	ns	
Output rise time	$t_{QLQH}$	$t_{RO}$	—	50	ns	2
Output fall time	$t_{QHQL}$	$t_{FO}$	—	50	ns	2
HOLD high to output low-Z	$t_{HHQX}$	$t_{LZ}$	—	50	ns	2
HOLD low to output high-Z	$t_{HLQZ}$	$t_{HZ}$	—	100	ns	2
Write time	$t_W$	$t_{WC}$	—	5	ms	

- Notes: 1.  $t_{CH} + t_{CL} \geq 1/f_C$   
 2. Not 100% tested.

(Ta = -40 to +105°C, V<sub>CC</sub> = 1.8 V to 5.5 V)

Parameter	Symbol	Alt	Min	Max	Unit	Notes
Clock frequency	f <sub>C</sub>	f <sub>SCK</sub>	—	3	MHz	
S active setup time	t <sub>SLCH</sub>	t <sub>CSS1</sub>	100	—	ns	
S not active setup time	t <sub>SHCH</sub>	t <sub>CSS2</sub>	100	—	ns	
S deselect time	t <sub>SHSL</sub>	t <sub>CS</sub>	150	—	ns	
S active hold time	t <sub>CHSH</sub>	t <sub>CSH</sub>	100	—	ns	
S not active hold time	t <sub>CHSL</sub>	—	100	—	ns	
Clock high time	t <sub>CH</sub>	t <sub>CLH</sub>	150	—	ns	1
Clock low time	t <sub>CL</sub>	t <sub>CLL</sub>	150	—	ns	1
Clock rise time	t <sub>CLCH</sub>	t <sub>RC</sub>	—	1	μs	2
Clock fall time	t <sub>CHCL</sub>	t <sub>FC</sub>	—	1	μs	2
Data in setup time	t <sub>DVCH</sub>	t <sub>DSU</sub>	30	—	ns	
Data in hold time	t <sub>CHDX</sub>	t <sub>DH</sub>	50	—	ns	
Clock low hold time after HOLD not active	t <sub>HHCH</sub>	—	140	—	ns	
Clock low hold time after HOLD active	t <sub>HLCH</sub>	—	90	—	ns	
Clock high setup time before HOLD active	t <sub>CHHL</sub>	—	120	—	ns	
Clock high setup time before HOLD not active	t <sub>CHHH</sub>	—	120	—	ns	
Output disable time	t <sub>SHQZ</sub>	t <sub>DIS</sub>	—	200	ns	2
Clock low to output valid	t <sub>CLQV</sub>	t <sub>V</sub>	—	120	ns	
Output hold time	t <sub>CLQX</sub>	t <sub>HO</sub>	0	—	ns	
Output rise time	t <sub>QLQH</sub>	t <sub>RO</sub>	—	100	ns	2
Output fall time	t <sub>QHQL</sub>	t <sub>FO</sub>	—	100	ns	2
HOLD high to output low-Z	t <sub>HHQX</sub>	t <sub>LZ</sub>	—	100	ns	2
HOLD low to output high-Z	t <sub>HLQZ</sub>	t <sub>HZ</sub>	—	100	ns	2
Write time	t <sub>w</sub>	t <sub>wc</sub>	—	5	ms	

Notes: 1. t<sub>CH</sub> + t<sub>CL</sub> ≥ 1/f<sub>C</sub>  
 2. Not 100% tested.

## Timing Waveforms

### Serial Input Timing

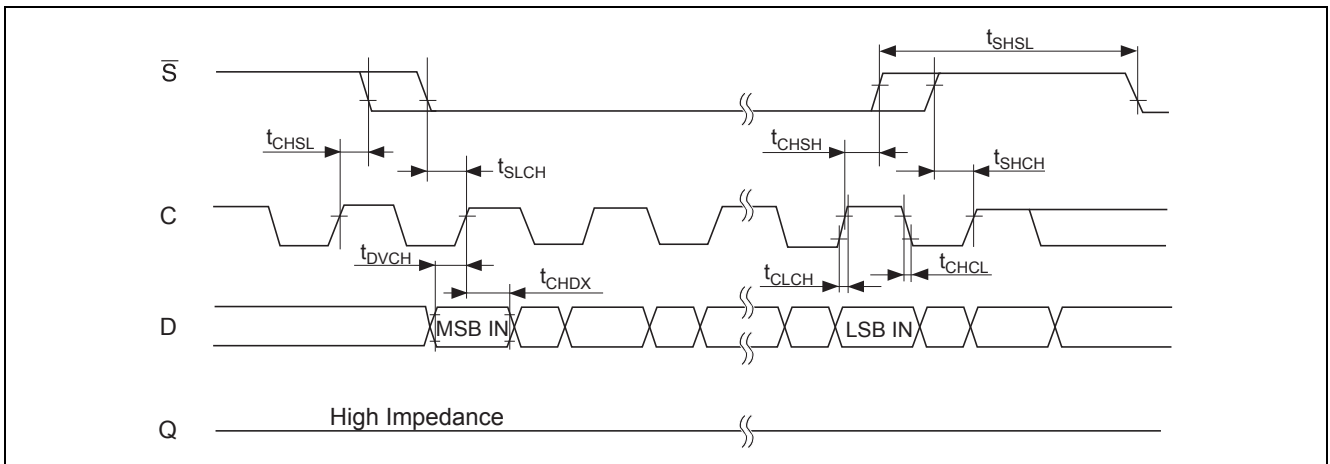

### Hold Timing

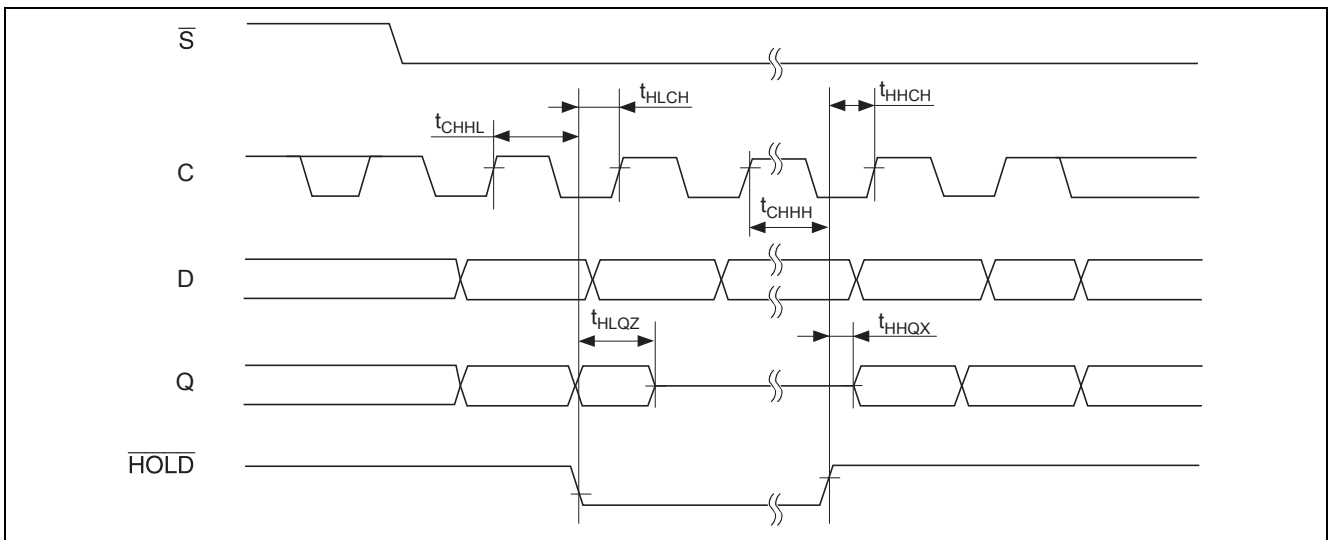

### Output Timing

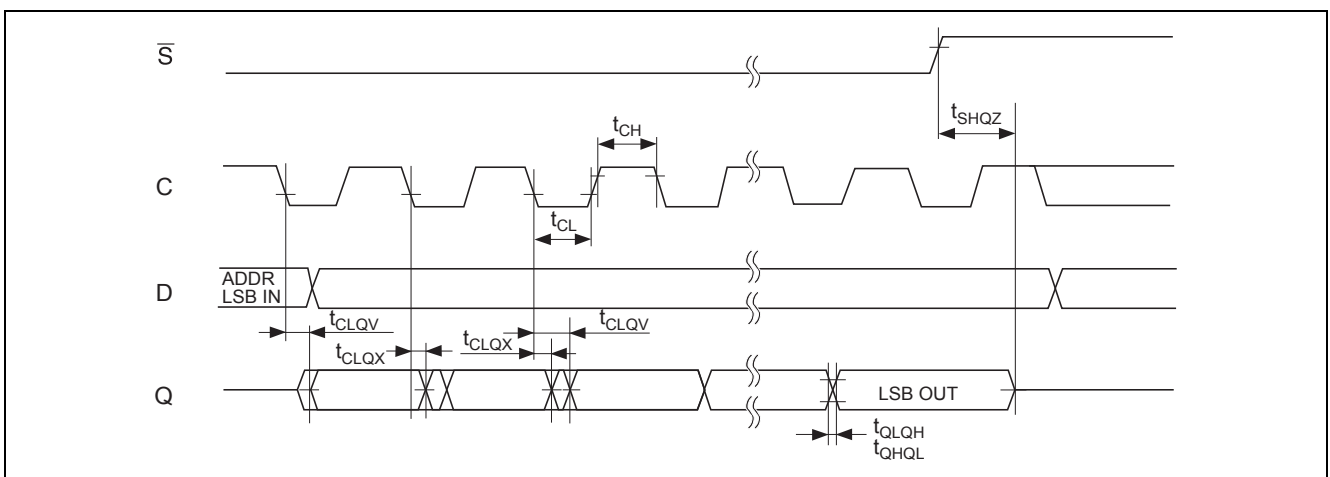

## Pin Function

### Serial data output (Q)

This output signal is used to transfer data serially out of the device. Data is shifted out on the falling edge of serial clock (C).

### Serial data input (D)

This input signal is used to transfer data serially into the device. It receives instructions, addresses, and the data to be written. Values are latched on the rising edge of serial clock (C).

### Serial clock (C)

This input signal provides the timing of the serial interface. Instructions, addresses, or data present at serial data input (D) are latched on the rising edge of serial clock (C). Data on serial data output (Q) changes after the falling edge of serial clock (C).

### Chip select (S)

When this input signal is high, the device is deselected and serial data output (Q) is at high impedance. Unless an internal write cycle is in progress, the device will be in the standby mode. Driving chip select (S) low enables the device, placing it in the active power mode. After power-up, a falling edge on chip select (S) is required prior to the start of any instruction.

### Hold (HOLD)

The hold (HOLD) signal is used to pause any serial communications with the device without deselecting the device. During the hold condition, the serial data output (Q) is high impedance, and serial data input (D) and serial clock (C) are don't care. To start the hold condition, the device must be selected, with chip select (S) driven low.

### Write protect (W)

The main purpose of this input signal is to freeze the size of the area of memory that is protected against write instructions (as specified by the values in the BP1 and BP0 bits of the status register). This pin must be driven either high or low, and must be stable during all write operations.



## Functional Description

### Status Register

The following figure shows the Status Register Format. The Status Register contains a number of status and control bits that can be read or set (as appropriate) by specific instructions.

### Status Register Format

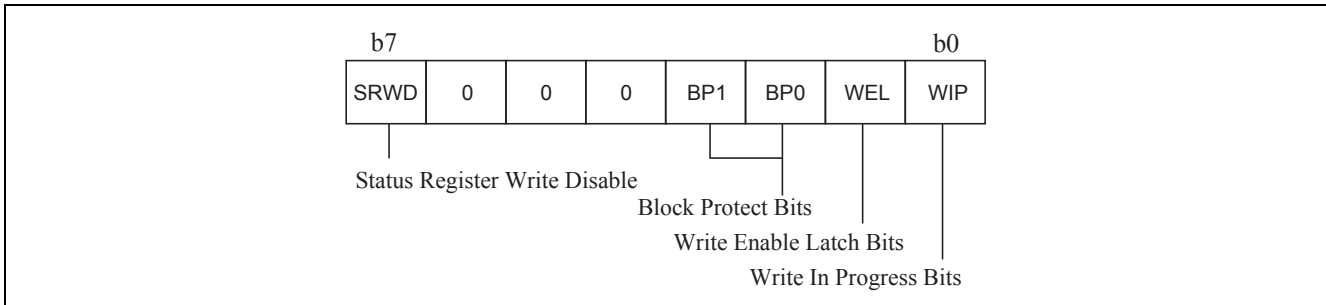

**WIP bit:** The Write In Progress (WIP) bit indicates whether the memory is busy with a Write or Write Status Register cycle.

**WEL bit:** The Write Enable Latch (WEL) bit indicates the status of the internal Write Enable Latch.

**BP1, BP0 bits:** The Block Protect (BP1, BP0) bits are non-volatile. They define the size of the area to be software protected against Write instructions.

**SRWD bit:** The Status Register Write Disable (SRWD) bit is operated in conjunction with the write protect (*W*) signal. The Status Register Write Disable (SRWD) bit and write protect (*W*) signal allow the device to be put in the Hardware Protected mode. In this mode, the non-volatile bits of the Status Register (SRWD, BP1, BP0) become read-only bits.

### Instructions

Each instruction starts with a single-byte code, as summarized in the following table. If an invalid instruction is sent (one not contained in the following table), the device automatically deselects itself.

### Instruction Set

Instruction	Description	Instruction Format
WREN	Write Enable	0000 0110
WRDI	Write Disable	0000 0100
RDSR	Read Status Register	0000 0101
WRSR	Write Status Register	0000 0001
READ	Read from Memory Array	0000 0011
WRITE	Write to Memory Array	0000 0010

**Write Enable (WREN):**

The Write Enable Latch (WEL) bit must be set prior to each WRITE and WRSR instruction. The only way to do this is to send a Write Enable instruction to the device. As shown in the following figure, to send this instruction to the device, chip select ( $\overline{S}$ ) is driven low, and the bits of the instruction byte are shifted in, on serial data input (D). The device then enters a wait state. It waits for the device to be deselected, by chip select ( $\overline{S}$ ) being driven high.

**Write Enable (WREN) Sequence**

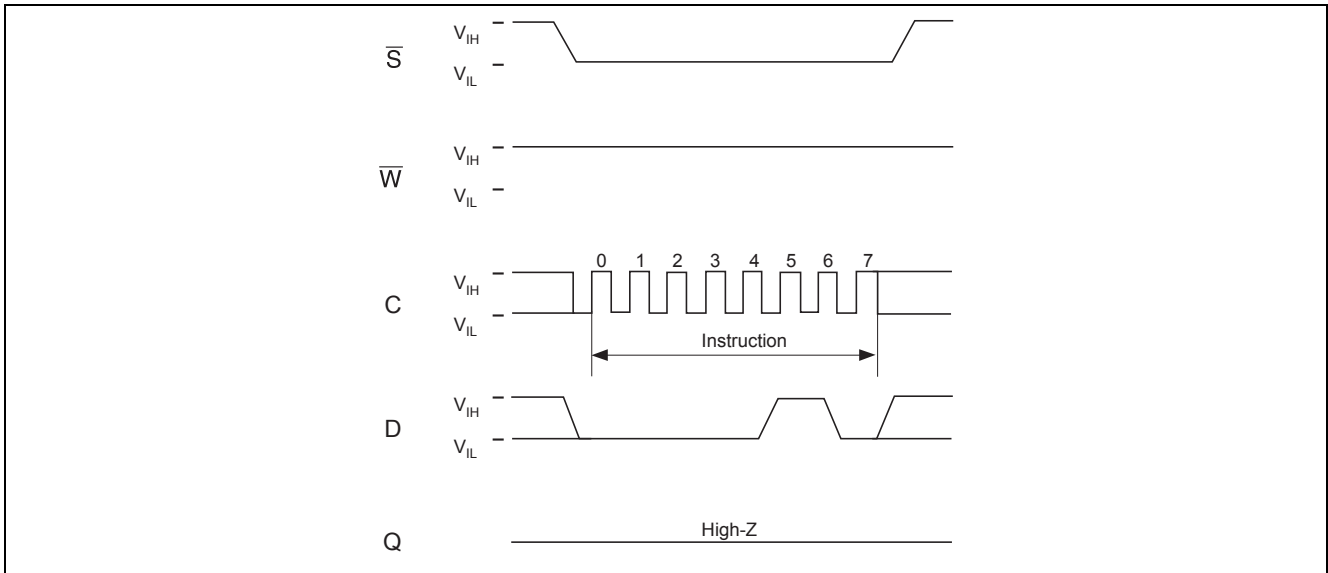

**Write Disable (WRDI):**

One way of resetting the Write Enable Latch (WEL) bit is to send a Write Disable instruction to the device. As shown in the following figure, to send this instruction to the device, chip select (**S**) is driven low, and the bits of the instruction byte are shifted in, on serial data input (**D**).

The device then enters a wait state. It waits for the device to be deselected, by chip select (**S**) being driven high. The Write Enable Latch (WEL) bit, in fact, becomes reset by any of the following events:

- Power-up
- WRDI instruction execution
- WRSR instruction completion
- WRITE instruction completion

**Write Disable (WRDI) Sequence**

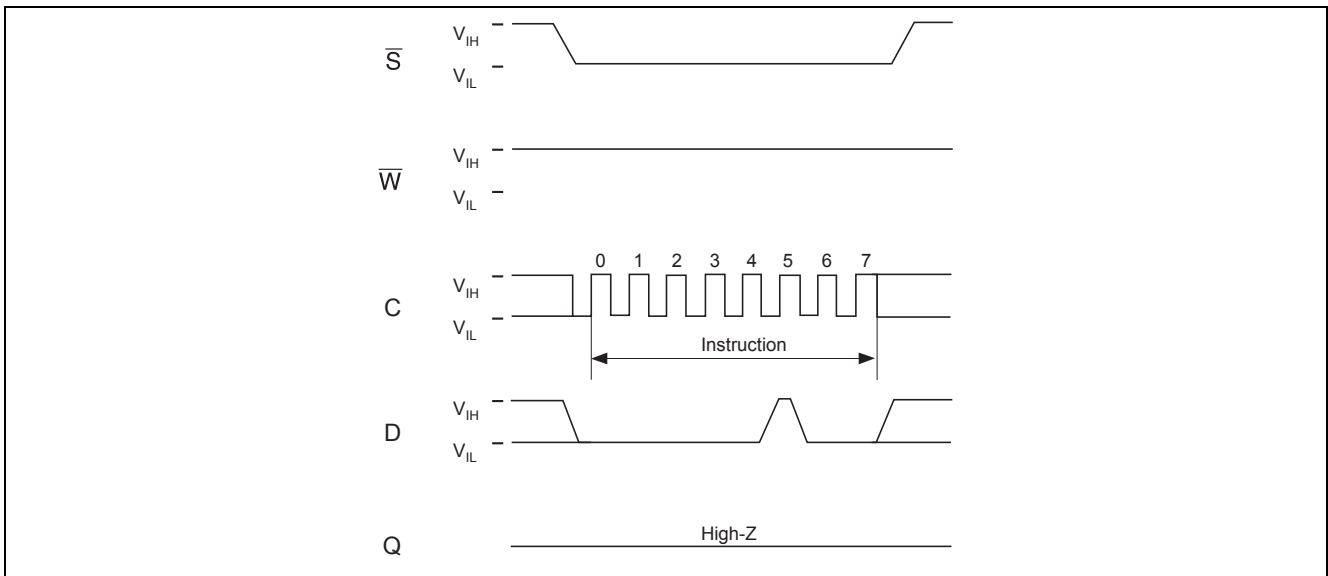

### Read Status Register (RDSR):

The Read Status Register (RDSR) instruction allows the Status Register to be read. The Status Register may be read at any time, even while a Write or Write Status Register cycle is in progress. When one of these cycles is in progress, it is recommended to check the Write In Progress (WIP) bit before sending a new instruction to the device. It is also possible to read the Status Register continuously, as shown in the following figure.

### Read Status Register (RDSR) Sequence

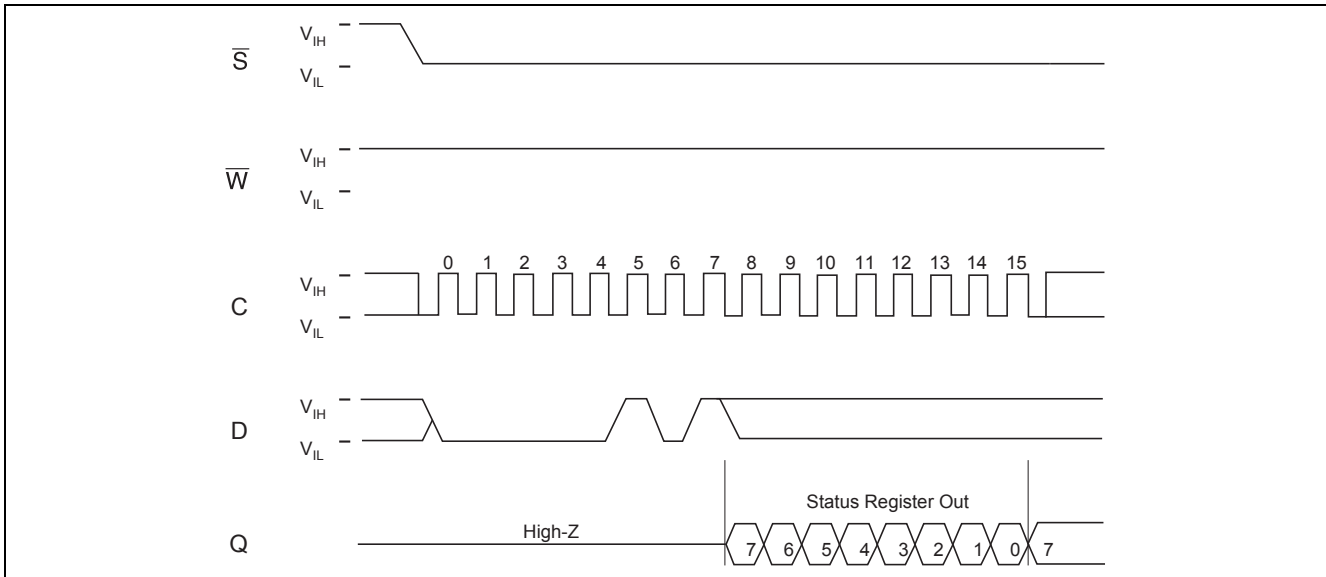

The status and control bits of the Status Register are as follows:

**WIP bit:** The Write In Progress (WIP) bit indicates whether the memory is busy with a Write or Write Status Register cycle. When set to 1, such a cycle is in progress. When reset to 0, no such cycles are in progress.

**WEL bit:** The Write Enable Latch (WEL) bit indicates the status of the internal Write Enable Latch. When set to 1, the internal Write Enable Latch is set. When set to 0, the internal Write Enable Latch is reset and no Write or Write Status Register instructions are accepted.

**BP1, BP0 bits:** The Block Protect (BP1, BP0) bits are non-volatile. They define the size of the area to be software protected against Write instructions. These bits are written with the Write Status Register (WRSR) instruction. When one or both of the Block Protect (BP1, BP0) bits are set to 1, the relevant memory area (as defined in the Status Register Format table) becomes protected against Write (WRITE) instructions. The Block Protect (BP1, BP0) bits can be written provided that the Hardware Protected mode has not been set.

**SRWD bit:** The Status Register Write Disable (SRWD) bit is operated in conjunction with the write protect ( $W$ ) signal. The Status Register Write Disable (SRWD) bit and write protect ( $W$ ) signal allows the device to be put in the Hardware Protected mode (When the Status Register Write Disable (SRWD) bit is set to 1, and write protect ( $W$ ) signal is driven low). In this mode, the non-volatile bits of the Status Register (SRWD, BP1, BP0) become read-only bits and the Write Status Register (WRSR) instruction is no longer accepted for execution.

**Write Status Register (WRSR):**

The Write Status Register (WRSR) instruction allows new values to be written to the Status Register. Before it can be accepted, a Write Enable (WREN) instruction must previously have been executed. After the Write Enable (WREN) instruction has been decoded and executed, the device sets the Write Enable Latch (WEL). The instruction sequence is shown in the following figure. The Write Status Register (WRSR) instruction has no effect on b6, b5, b4, b1 and b0 of the Status Register. b6, b5 and b4 are always read as 0. Chip select ( $\overline{S}$ ) must be driven high after the rising edge of serial clock (C) that latches in the eighth bit of the data byte, and before the next rising edge of serial clock (C). Otherwise, the Write Status Register (WRSR) instruction is not executed. As soon as chip select ( $\overline{S}$ ) is driven high, the self-timed Write Status Register cycle (whose duration is  $t_w$ ) is initiated. While the Write Status Register cycle is in progress, the Status Register may still be read to check the value of the Write In Progress (WIP) bit. The Write In Progress (WIP) bit is 1 during the self-timed Write Status Register cycle, and is 0 when it is completed. When the cycle is completed, Write Enable Latch (WEL) is reset. The Write Status Register (WRSR) instruction allows the user to change the values of the Block Protect (BP1, BP0) bits, to define the size of the area that is to be treated as read-only, as defined in the Status Register Format table.

The Write Status Register (WRSR) instruction also allows the user to set or reset the Status Register Write Disable (SRWD) bit in accordance with the write protect ( $\overline{W}$ ) signal. The Status Register Write Disable (SRWD) bit and write protect ( $\overline{W}$ ) signal allows the device to be put in the Hardware Protected Mode (HPM). The Write Status Register (WRSR) instruction is not executed once the Hardware Protected Mode (HPM) is entered.

The contents of the Status Register Write Disable (SRWD) and Block Protect (BP1, BP0) bits are frozen at their current values just before the start of the execution of the Write Status Register (WRSR) instruction. The new, updated values take effect at the moment of completion of the execution of Write Status Register (WRSR) instruction.

**Write Status Register (WRSR) Sequence**

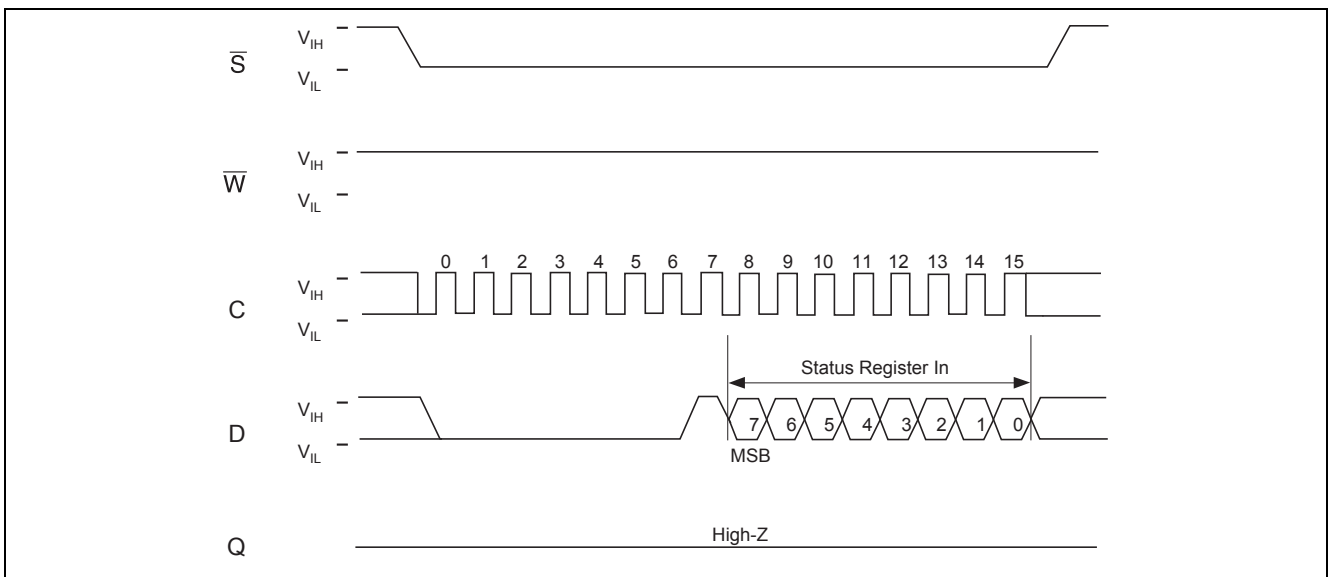

**Read from Memory Array (READ):**

As shown in the following figure, to send this instruction to the device, chip select (**S**) is first driven low. The bits of the instruction byte and the address bytes are then shifted in, on serial data input (**D**). The addresses are loaded into an internal address register, and the byte of data at that address is shifted out, on serial data output (**Q**).

If chip select (**S**) continues to be driven low, the internal address register is automatically incremented, and the byte of data at the new address is shifted out.

When the highest address is reached, the address counter rolls over to zero, allowing the Read cycle to be continued indefinitely. The whole memory can, therefore, be read with a single READ instruction.

The Read cycle is terminated by driving chip select (**S**) high. The rising edge of the chip select (**S**) signal can occur at any time during the cycle. The addressed first byte can be any byte within any page. The instruction is not accepted, and is not executed, if a Write cycle is currently in progress.

**Read from Memory Array (READ) Sequence**

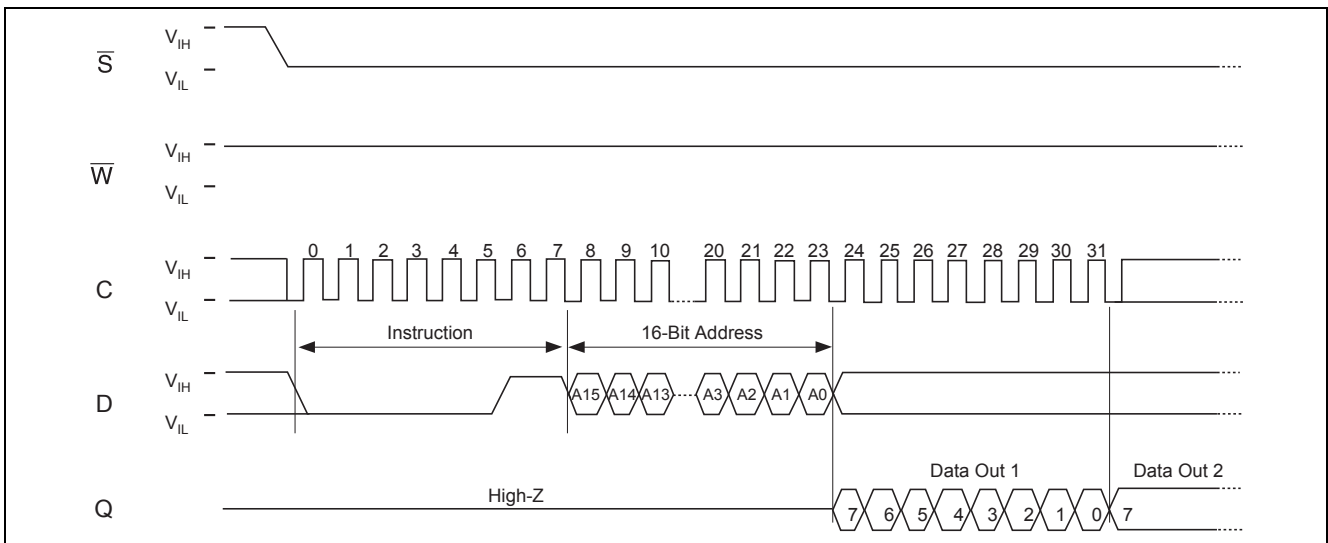

Note: 1. Depending on the memory size, as shown in the following table, the most significant address bits are don't care.

**Address Range Bits**

Device	R1EX25016A	R1EX25008A
Address bits	A10 to A0	A9 to A0

Notes: 1. b15-b11 are don't care on the R1EX25016A  
 2. b15-b10 are don't care on the R1EX25008A

**Write to Memory Array (WRITE):**

As shown in the following figure, to send this instruction to the device, chip select (**S**) is first driven low. The bits of the instruction byte, address byte, and at least one data byte are then shifted in, on serial data input (**D**).

The instruction is terminated by driving chip select (**S**) high at a byte boundary of the input data. In the case of the following figure, this occurs after the eighth bit of the data byte has been latched in, indicating that the instruction is being used to write a single byte. The self-timed Write cycle starts, and continues for a period  $t_{WC}$  (as specified in AC Characteristics). At the end of the cycle, the Write In Progress (WIP) bit is reset to 0.

If, though, chip select (**S**) continues to be driven low, as shown in the following figure, the next byte of the input data is shifted in, so that more than a single byte, starting from the given address towards the end of the same page, can be written in a single internal Write cycle.

Each time a new data byte is shifted in, the least significant bits of the internal address counter are incremented. If the number of data bytes sent to the device exceeds the page boundary, the internal address counter rolls over to the beginning of the page, and the previous data there are overwritten with the incoming data. (The page size of these device is 32 bytes).

The instruction is not accepted, and is not executed, under the following conditions:

- If the Write Enable Latch (WEL) bit has not been set to 1 (by executing a Write Enable instruction just before)
- If a Write cycle is already in progress
- If the addressed page is in the region protected by the Block Protect (BP1 and BP0) bits.

**Byte Write (WRITE) Sequence (1 Byte)**

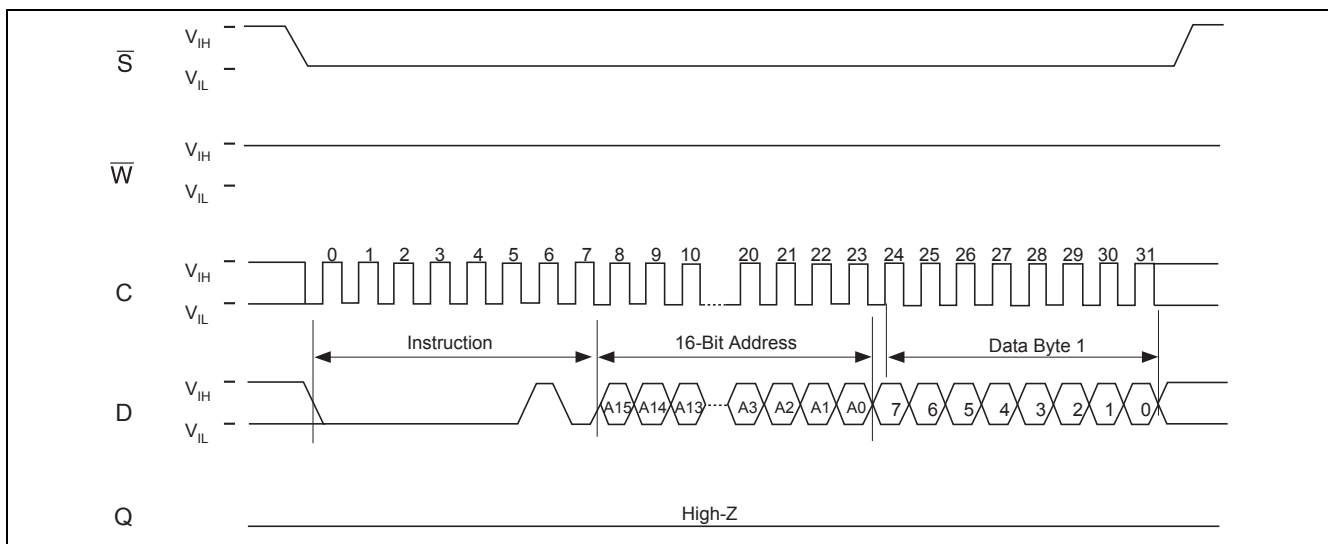

Note: 1. Depending on the memory size, as shown in Address Range Bits table, the most significant address bits are don't care.

Byte Write (WRITE) Sequence (Page)

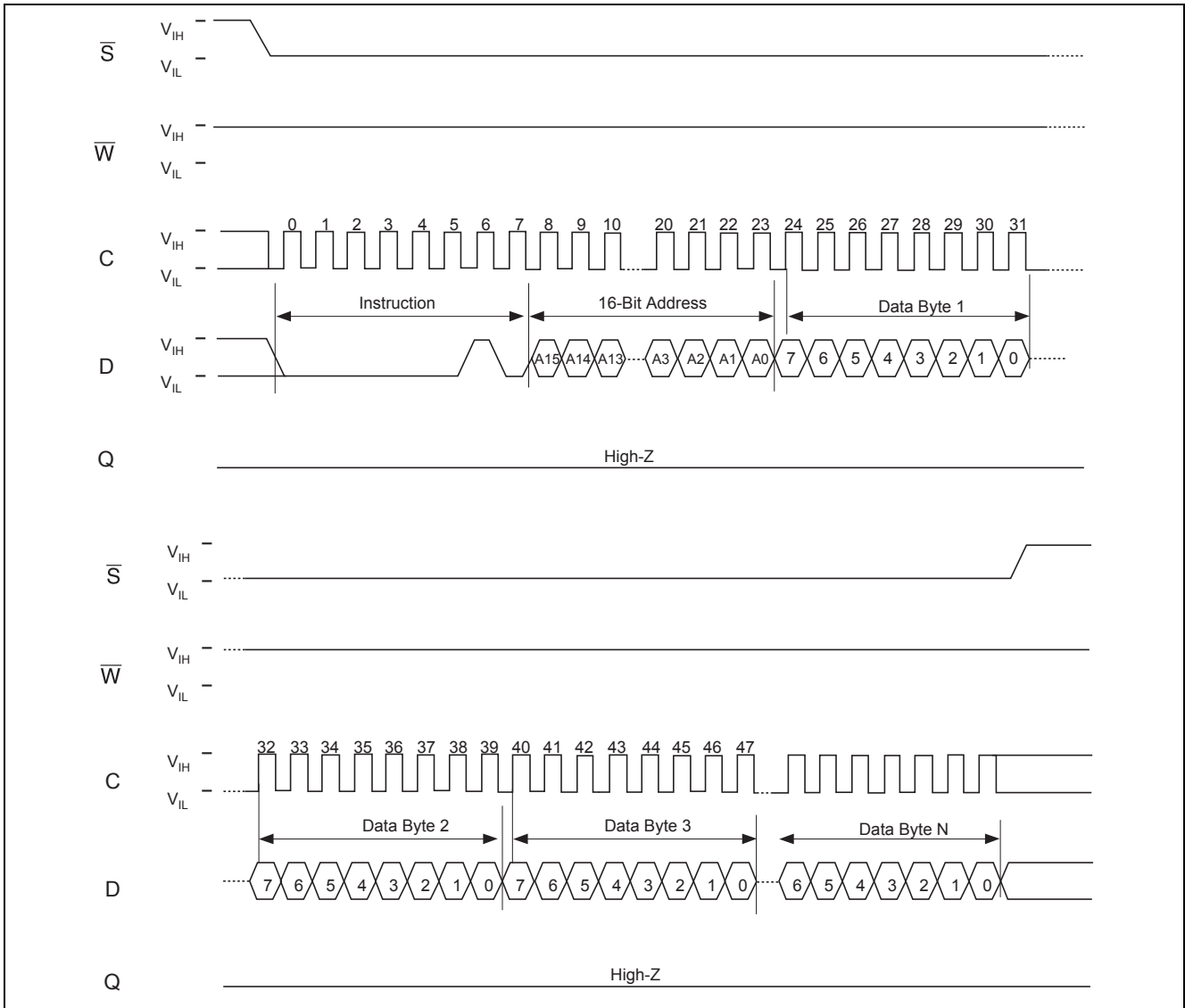

Note: 1. Depending on the memory size, as shown in Address Range Bits table, the most significant address bits are don't care.



## Data Protect

The protection features of the device are summarized in the following table. When the Status Register Write Disable (SRWD) bit of the Status Register is 0 (its initial delivery state), it is possible to write to the Status Register provided that the Write Enable Latch (WEL) bit has previously been set by a Write Enable (WREN) instruction, regardless whether write protect (W) is driven high or low.

When the Status Register Write Disable (SRWD) bit of the Status Register is set to 1, two cases need to be considered, depending on the state of write protect (W):

- If write protect (W) is driven high, it is possible to write to the Status Register provided that the Write Enable Latch (WEL) bit has previously been set by a Write Enable (WREN) instruction.
- If write protect (W) is driven low, it is not possible to write to the Status Register even if the Write Enable Latch (WEL) bit has previously been set by a Write Enable (WREN) instruction. (Attempts to write to the Status Register are rejected, and are not accepted for execution). As a consequence, all the data bytes in the memory area that are software protected (SPM) by the Block Protect (BP1, BP0) bits of the Status Register, are also hardware protected against data modification.

Regardless of the order of the two events, the Hardware Protected Mode (HPM) can be entered:

- By setting the Status Register Write Disable (SRWD) bit after driving write protect (W) low.
- By driving write protect (W) low after setting the Status Register Write Disable (SRWD) bit.

The only way to exit the Hardware Protected Mode (HPM) once entered is to pull write protect (W) high.

If write protect (W) is permanently tied high, the Hardware Protected Mode (HPM) can never be activated, and only the Software Protected Mode (SPM), using the Block Protect (BP1, BP0) bits of the Status Register, can be used.

## Write Protected Block Size

Status register bits		Protected blocks	Array addresses protected	
BP1	BP0		R1EX25016A	R1EX25008A
0	0	None	None	None
0	1	Upper quarter	600h – 7FFh	300h – 3FFh
1	0	Upper half	400h – 7FFh	200h – 3FFh
1	1	Whole memory	000h – 7FFh	000h – 3FFh

## Protection Modes

W signal	SRWD bit	Mode	Write protection of the status register	Memory protect	
				Protected area* <sup>1</sup>	Unprotected area* <sup>1</sup>
1	0	Software protected (SPM)	Status register is writable (if the WREN) instruction has set the WEL bit). The values in the BP1 and BP0 bits can be changed.	Write protected	Ready to accept Write instructions
0	0				
1	1				
0	1	Hardware protected (HPM)	Status register is hardware write protected. The values in the BP1 and BP0 bits cannot be changed.	Write protected	Ready to accept Write instructions

Note: 1. As defined by the values in the Block Protected (BP1, BP0) bits of the Status Register, as shown in the Write Protected Block Size table.

## Hold Condition

The hold (HOLD) signal is used to pause any serial communications with the device without resetting the clocking sequence.

During the hold condition, the serial data output (Q) is high impedance, and serial data input (D) and serial clock (C) are don't care.

To enter the hold condition, the device must be selected, with chip select (S) low.

Normally, the device is kept selected, for the whole duration of the hold condition. Deselecting the device while it is in the hold condition, has the effect of resetting the state of the device, and this mechanism can be used if it is required to reset any processes that had been in progress.

The hold condition starts when the hold (HOLD) signal is driven low at the same time as serial clock (C) already being low (as shown in the following figure).

The hold condition ends when the hold (HOLD) signal is driven high at the same time as serial clock (C) already being low.

The following figure also shows what happens if the rising and falling edges are not timed to coincide with serial clock (C) being low.

### Hold Condition Activation

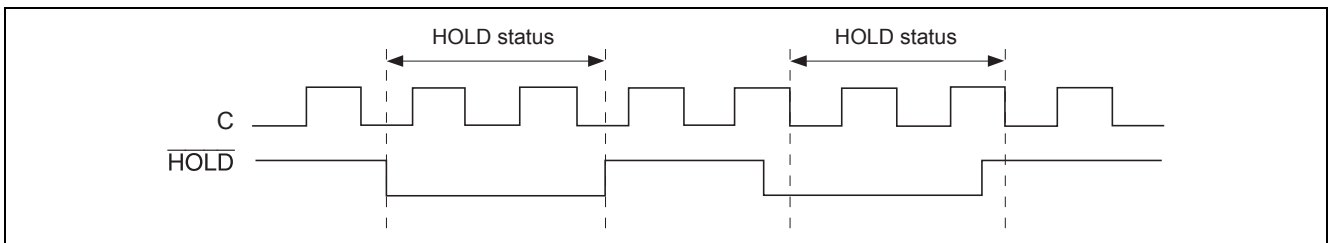

## Notes

### Data Protection at V<sub>CC</sub> On/Off

When V<sub>CC</sub> is turned on or off, noise on S inputs generated by external circuits (CPU, etc) may act as a trigger and turn the EEPROM to unintentional program mode. To prevent this unintentional programming, this EEPROM have a power on reset function. Be careful of the notices described below in order for the power on reset function to operate correctly.

- S should be fixed to V<sub>CC</sub> during V<sub>CC</sub> on/off. Low to high or high to low transition during V<sub>CC</sub> on/off may cause the trigger for the unintentional programming.
- V<sub>CC</sub> should be turned on/off after the EEPROM is placed in a standby state.
- V<sub>CC</sub> should be turned on from the ground level (V<sub>SS</sub>) in order for the EEPROM not to enter the unintentional programming mode.
- V<sub>CC</sub> turn on rate should be slower than 2 μs/V.
- When WRSR or WRITE instruction is executed before V<sub>CC</sub> turns off, V<sub>CC</sub> should be turned off after waiting write cycle time (t<sub>w</sub>).

### Power Source Noise Countermeasures

In order to suppress power-source-noise which causes malfunction of the device, it is recommended to put 0.1μF bypass-capacitor (such as a monolithic ceramic capacitor which has good high-frequency characteristics) between V<sub>CC</sub> and V<sub>SS</sub>, and shorten the wiring length between the capacitor and V<sub>CC</sub>/V<sub>SS</sub> terminals as much as possible.

## Package Dimensions

### R1EX25008ASA00G/R1EX25016ASA00G (PRSP0008DF-B / Previous Code: FP-8DBV)

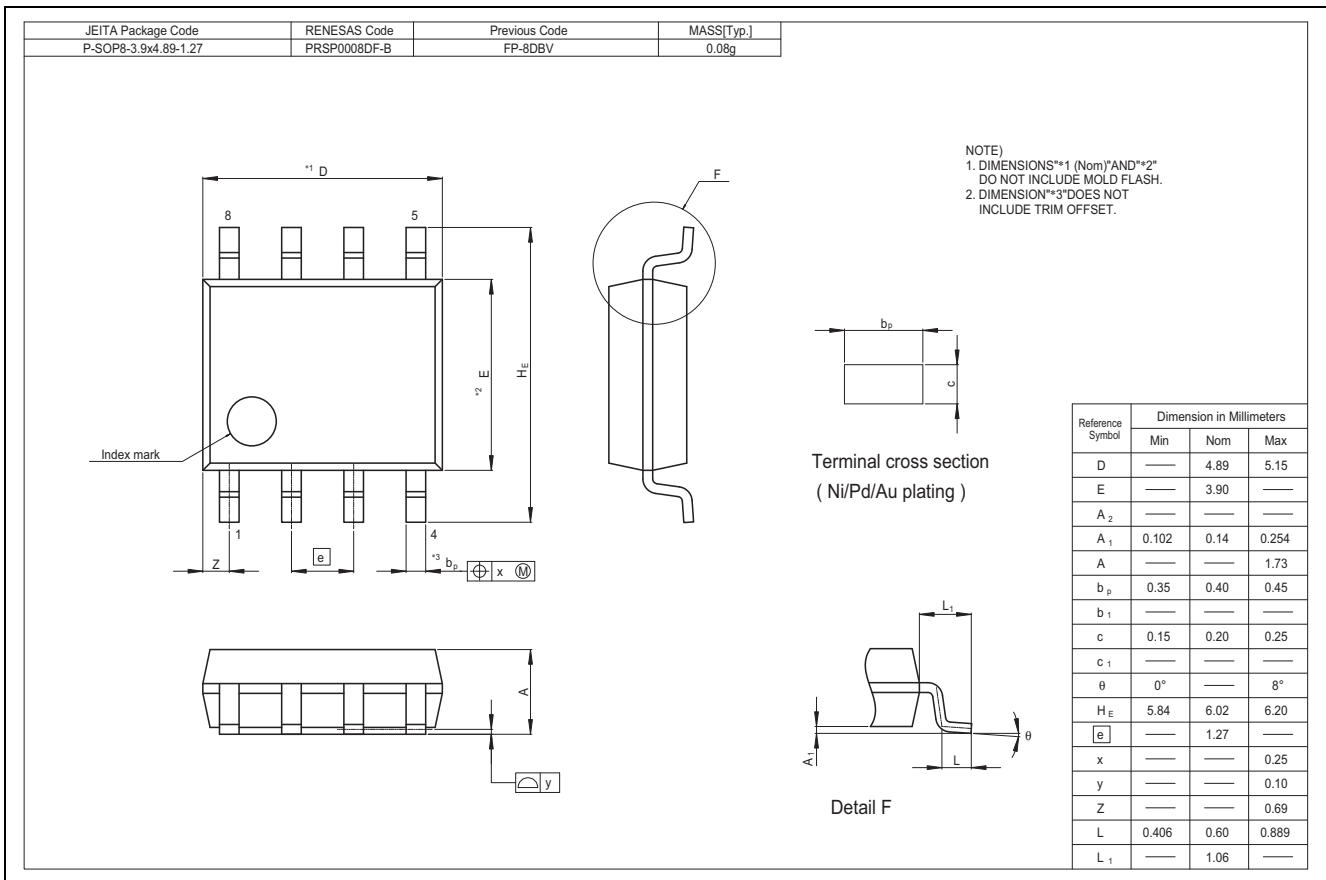

R1EX25008ATA00G/R1EX25016ATA00G (PTSP0008JC-B / Previous Code: TTP-8DAV)

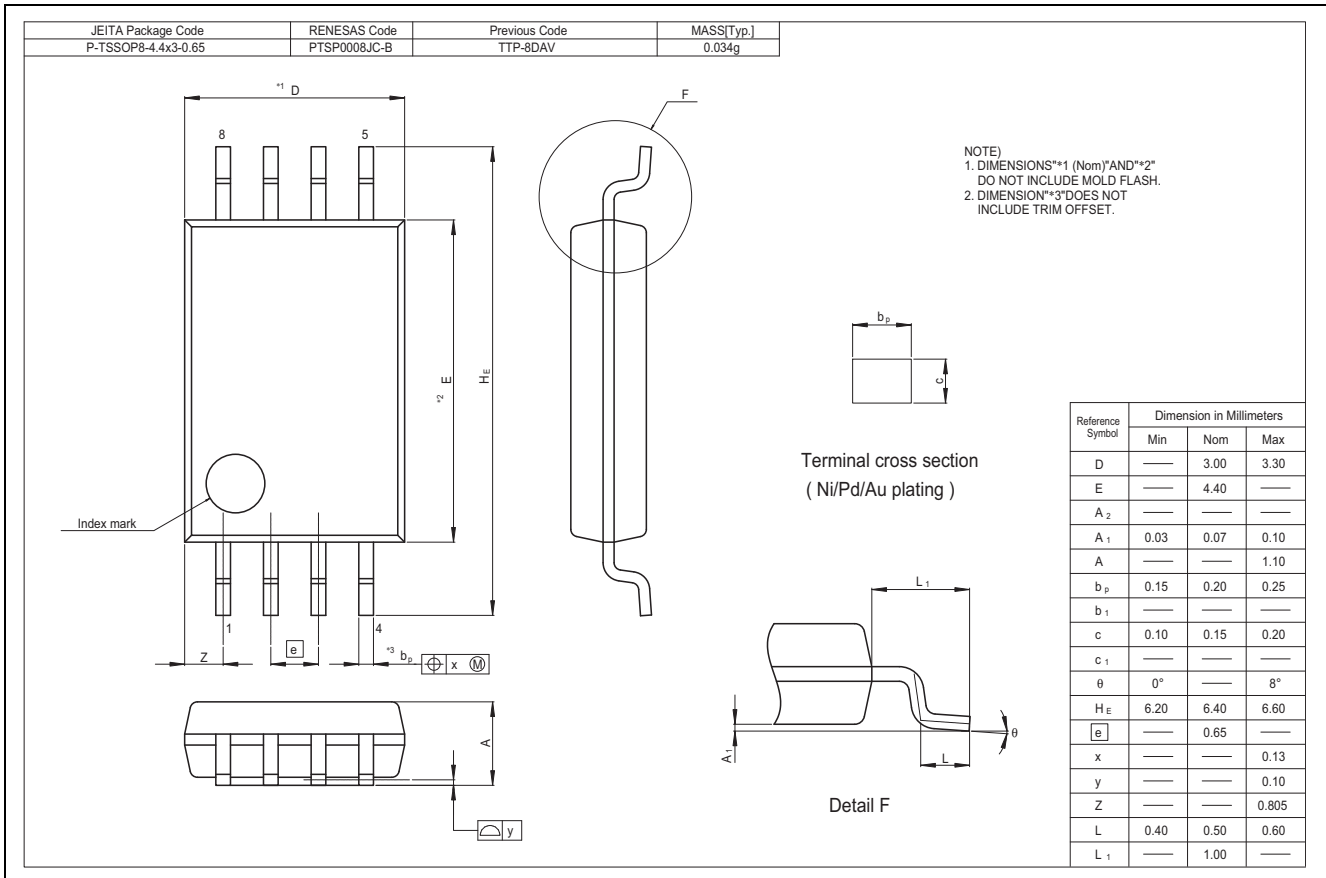

**Revision History****R1EX25008ASA00G/R1EX25008ATA00G/  
R1EX25016ASA00G/R1EX25016ATA00G Data Sheet**

Rev.	Date	Description	
		Page	Summary
0.01	May. 16, 2011	—	Initial issue
1.00	Oct. 02, 2012	—	Delete Preliminary
		1	Data retention: Change 10 Years to 20 Years.
		2	Ordering Information: Change #S0 to #U0. Addition of Halogen free. Memory cell characteristics: Data retention: Change 10 Years to 20 Years.
		3	Block Diagram: Addition of Voltage detector. Addition DC characteristics $I_{SB} = 0.5\mu A(Typ)@3.6V$ , $I_{CC1} = 0.7mA(Typ)@3.6V$ , $I_{CC2} = 1.2mA(Typ)@3.6V$
18	Addition these items for Notes (Power Source Noise Countermeasures)		

All trademarks and registered trademarks are the property of their respective owners.

## Notice

- All information included in this document is current as of the date this document is issued. Such information, however, is subject to change without any prior notice. Before purchasing or using any Renesas Electronics products listed herein, please confirm the latest product information with a Renesas Electronics sales office. Also, please pay regular and careful attention to additional and different information to be disclosed by Renesas Electronics such as that disclosed through our website.
- Renesas Electronics does not assume any liability for infringement of patents, copyrights, or other intellectual property rights of third parties by or arising from the use of Renesas Electronics products or technical information described in this document. No license, express, implied or otherwise, is granted hereby under any patents, copyrights or other intellectual property rights of Renesas Electronics or others.
- You should not alter, modify, copy, or otherwise misappropriate any Renesas Electronics product, whether in whole or in part.
- Descriptions of circuits, software and other related information in this document are provided only to illustrate the operation of semiconductor products and application examples. You are fully responsible for the incorporation of these circuits, software, and information in the design of your equipment. Renesas Electronics assumes no responsibility for any losses incurred by you or third parties arising from the use of these circuits, software, or information.
- When exporting the products or technology described in this document, you should comply with the applicable export control laws and regulations and follow the procedures required by such laws and regulations. You should not use Renesas Electronics products or the technology described in this document for any purpose relating to military applications or use by the military, including but not limited to the development of weapons of mass destruction. Renesas Electronics products and technology may not be used for or incorporated into any products or systems whose manufacture, use, or sale is prohibited under any applicable domestic or foreign laws or regulations.
- Renesas Electronics has used reasonable care in preparing the information included in this document, but Renesas Electronics does not warrant that such information is error free. Renesas Electronics assumes no liability whatsoever for any damages incurred by you resulting from errors in or omissions from the information included herein.
- Renesas Electronics products are classified according to the following three quality grades: "Standard", "High Quality", and "Specific". The recommended applications for each Renesas Electronics product depends on the product's quality grade, as indicated below. You must check the quality grade of each Renesas Electronics product before using it in a particular application. You may not use any Renesas Electronics product for any application categorized as "Specific" without the prior written consent of Renesas Electronics. Further, you may not use any Renesas Electronics product for any application for which it is not intended without the prior written consent of Renesas Electronics. Renesas Electronics shall not be in any way liable for any damages or losses incurred by you or third parties arising from the use of any Renesas Electronics product for an application categorized as "Specific" or for which the product is not intended where you have failed to obtain the prior written consent of Renesas Electronics. The quality grade of each Renesas Electronics product is "Standard" unless otherwise expressly specified in a Renesas Electronics data sheets or data books, etc.  
"Standard": Computers; office equipment; communications equipment; test and measurement equipment; audio and visual equipment; home electronic appliances; machine tools; personal electronic equipment; and industrial robots.  
"High Quality": Transportation equipment (automobiles, trains, ships, etc.); traffic control systems; anti-disaster systems; anti-crime systems; safety equipment; and medical equipment not specifically designed for life support.  
"Specific": Aircraft; aerospace equipment; submersible repeaters; nuclear reactor control systems; medical equipment or systems for life support (e.g. artificial life support devices or systems), surgical implantations, or healthcare intervention (e.g. excision, etc.), and any other applications or purposes that pose a direct threat to human life.
- You should use the Renesas Electronics products described in this document within the range specified by Renesas Electronics, especially with respect to the maximum rating, operating supply voltage range, movement power voltage range, heat radiation characteristics, installation and other product characteristics. Renesas Electronics shall have no liability for malfunctions or damages arising out of the use of Renesas Electronics products beyond such specified ranges.
- Although Renesas Electronics endeavors to improve the quality and reliability of its products, semiconductor products have specific characteristics such as the occurrence of failure at a certain rate and malfunctions under certain use conditions. Further, Renesas Electronics products are not subject to radiation resistance design. Please be sure to implement safety measures to guard them against the possibility of physical injury, and injury or damage caused by fire in the event of the failure of a Renesas Electronics product, such as safety design for hardware and software including but not limited to redundancy, fire control and malfunction prevention, appropriate treatment for aging degradation or any other appropriate measures. Because the evaluation of microcomputer software alone is very difficult, please evaluate the safety of the final products or system manufactured by you.
- Please contact a Renesas Electronics sales office for details as to environmental matters such as the environmental compatibility of each Renesas Electronics product. Please use Renesas Electronics products in compliance with all applicable laws and regulations that regulate the inclusion or use of controlled substances, including without limitation, the EU RoHS Directive. Renesas Electronics assumes no liability for damages or losses occurring as a result of your noncompliance with applicable laws and regulations.
- This document may not be reproduced or duplicated, in any form, in whole or in part, without prior written consent of Renesas Electronics.
- Please contact a Renesas Electronics sales office if you have any questions regarding the information contained in this document or Renesas Electronics products, or if you have any other inquiries.  
(Note 1) "Renesas Electronics" as used in this document means Renesas Electronics Corporation and also includes its majority-owned subsidiaries.  
(Note 2) "Renesas Electronics product(s)" means any product developed or manufactured by or for Renesas Electronics.



### SALES OFFICES

Renesas Electronics Corporation

<http://www.renesas.com>

Refer to "<http://www.renesas.com/>" for the latest and detailed information.

**Renesas Electronics America Inc.**  
2880 Scott Boulevard Santa Clara, CA 95050-2554, U.S.A.  
Tel: +1-408-588-6000, Fax: +1-408-588-6130

**Renesas Electronics Canada Limited**  
1101 Nicholson Road, Newmarket, Ontario L3Y 9C3, Canada  
Tel: +1-905-898-5441, Fax: +1-905-898-3220

**Renesas Electronics Europe Limited**  
Dukes Meadow, Millboard Road, Bourne End, Buckinghamshire, SL8 5FH, U.K.  
Tel: +44-1628-585-100, Fax: +44-1628-585-900

**Renesas Electronics Europe GmbH**  
Arcadiastrasse 10, 40472 Düsseldorf, Germany  
Tel: +49-211-65030, Fax: +49-211-6503-1327

**Renesas Electronics (China) Co., Ltd.**  
7th Floor, Quantum Plaza, No.27 ZhiChunLu Haidian District, Beijing 100083, P.R.China  
Tel: +86-10-8235-1155, Fax: +86-10-8235-7679

**Renesas Electronics (Shanghai) Co., Ltd.**  
Unit 204, 205, AZIA Center, No.1233 Lujiazui Ring Rd., Pudong District, Shanghai 200120, China  
Tel: +86-21-5877-1818, Fax: +86-21-6887-7858 / -7898

**Renesas Electronics Hong Kong Limited**  
Unit 1601-1613, 16/F., Tower 2, Grand Century Place, 193 Prince Edward Road West, Mongkok, Kowloon, Hong Kong  
Tel: +852-2886-9318, Fax: +852 2886-9022/9044

**Renesas Electronics Taiwan Co., Ltd.**  
13F, No. 363, Fu Shing North Road, Taipei, Taiwan  
Tel: +886-2-8175-9600, Fax: +886 2-8175-9670

**Renesas Electronics Singapore Pte. Ltd.**  
1 HarbourFront Avenue, #06-10, Keppel Bay Tower, Singapore 098632  
Tel: +65-6213-0200, Fax: +65-6278-8001

**Renesas Electronics Malaysia Sdn.Bhd.**  
Unit 906, Block B, Menara Amcorp, Amcorp Trade Centre, No. 18, Jin Persiaran Barat, 46050 Petaling Jaya, Selangor Darul Ehsan, Malaysia  
Tel: +60-3-7955-9390, Fax: +60-3-7955-9510

**Renesas Electronics Korea Co., Ltd.**  
11F., Samik Lavied' or Bldg., 720-2 Yeoksam-Dong, Kangnam-Ku, Seoul 135-080, Korea  
Tel: +82-2-558-3737, Fax: +82-2-558-5141