

General purpose transistors (dual transistors)

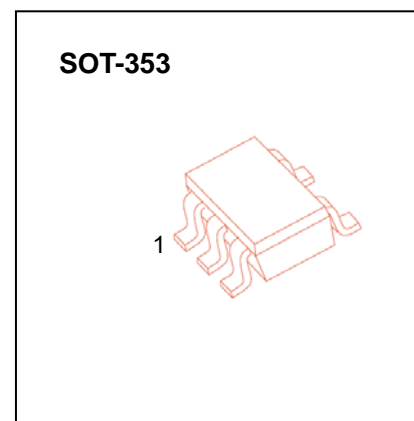

FEATURES

- Two DTC143T chips in a package
- Mounting possible with SOT-353 automatic mounting machines.
- Transistor elements are independent, eliminating interference.
- Mounting cost and area be cut in half.

Marking: G3

Equivalent circuit

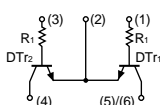

Absolute maximum ratings (Ta=25°C)

Symbol	Parameter	LIMITS	Unit
V _{CBO}	Collector-Base Voltage	50	V
V _{CEO}	Collector-Emitter Voltage	50	V
V _{EBO}	Emitter-Base Voltage	5	V
I _C	Collector Current -Continuous	100	mA
P _C	Collector Dissipation	150	mW
T _j	Junction temperature	150	°C
T _{stg}	Storage Temperature	-55~+150	°C

ELECTRICAL CHARACTERISTICS (Ta=25°C unless otherwise specified)

Parameter	Symbol	Test conditions	Min	Typ	Max	Unit
Collector-base breakdown voltage	V _{(BR)CBO}	I _C =50μA, I _E =0	50			V
Collector-emitter breakdown voltage	V _{(BR)CEO}	I _C =1mA, I _B =0	50			V
Emitter-base breakdown voltage	V _{(BR)EBO}	I _E =50μA, I _C =0	5			V
Collector cut-off current	I _{CBO}	V _{CB} =50V, I _E =0			0.5	μA
Emitter cut-off current	I _{EBO}	V _{EB} =4V, I _C =0			0.5	μA
DC current gain	h _{FE}	V _{CE} =5V, I _C =1mA	100		600	
Collector-emitter saturation voltage	V _{CE(sat)}	I _C =5mA, I _B =0.25mA			0.3	V
Transition frequency	f _T	V _{CE} =10V, I _E =-5mA, f=100MHz		250		MHz
Input resistor	R ₁		3.29	4.7	6.11	kΩ