

KA8503

LOW VOLTAGE SPEECH NETWORK

INTRODUCTION

The KA8503 is a telephone low voltage speech network which includes mic amp, transmit amp, side-tone amp, receive amp. It handles the voice signal performing the 2/4 wire interface and changing the gain on both sending and receiving amplifiers to compensate for line attenuation by sensing the line length through the line current. Application dependent parameters such as amplitude of each amp, sidetone level line balance, and frequency response are controlled by external components. Each gain can be controlled by external component exchange. The receiver output driving capability is adjustable.

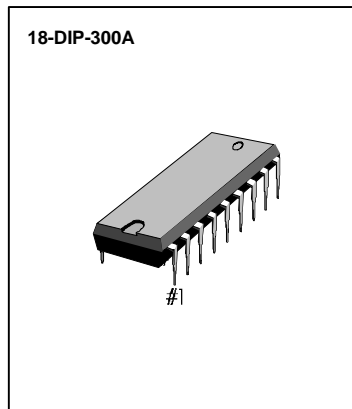

FEATURES

- Adjust Sending and Receiving Attenuation Length
- Mute Function
- Side Tone Balance Network Constitution
- Low Voltage Operating
- AC Impedance Matching
- Uses in Inexpensive Components (5 Capacitors & 10 Resistors)
- Uses a minimum of external components

ORDERING INFORMATION

Device	Package	Operating Temperature
KA8503	18-DIP-300A	- 40°C ~ + 70°C

BLOCK DIAGRAM

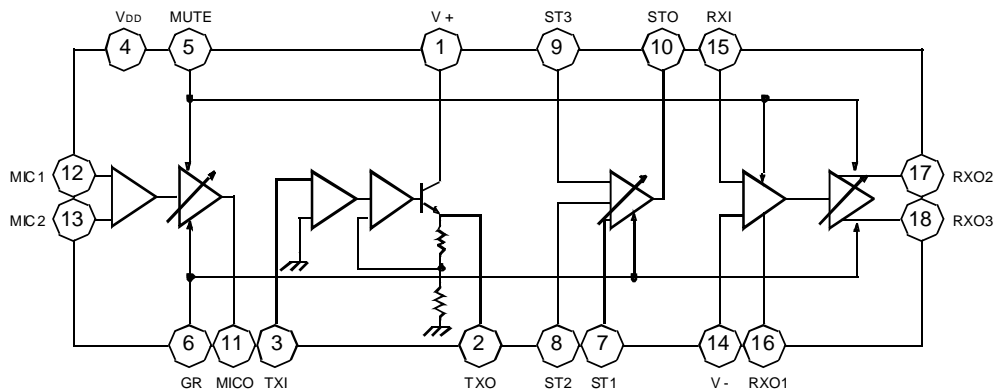

Fig. 1

PIN CONFIGURATION

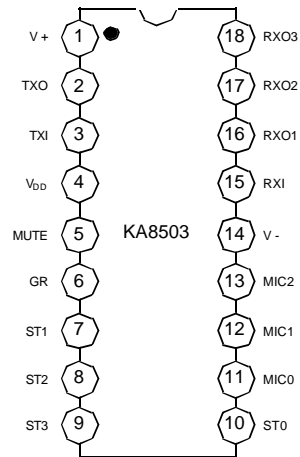

Fig. 2

PIN DESCRIPTION

Pin No	Symbol	Description
1	V +	Postive power line and transmit amplifier output.
2	TXO	Transmit amplifier output. The resistor which is connected this pin to V - sets DC resistance of the circuit. The value of resistor is suitable for 47 ~ 100Ω.
3	TXI	Transmit amplifier input. Input impedance is 17KΩ ± 20%
4	V _{DD}	DC power supply pin. This pin will be connected to a decoupling capacitor 47μF~ 100 μF.
5	MUTE	Mute active high input.
6	GR	Gain regulation control input. Input impedance is 5.5 KΩ ± 20%.
7, 8, 9	ST1, ST2, ST3	Seperate amplifier control inputs.
10	STO	Seperate amplifier output.
11	MIC0	Microphone amplifier output.
12, 13	MIC1, MIC2	Microphone amplifier inputs. Input impedance is 1.7 KΩ ± 20%
14	V -	Negative power line.
15	RXI	Receive amplifier input.
16	RXO1	Receive amplifier output.
17, 18	RXO2, ROX3	Receive amplifier output. Output impedance is 3Ω(Typ)

ABSOLUTE MAXIMUM RATINGS

Characteristic	Symbol	Value	Unit
Line Voltage (3ms max)	V_L	22	V
Forward Line Current	I_{LF}	150	mA
Reverse Line Current	I_{LR}	-150	mA
Power Dissipation (Ta = 70°C)	P_D	1	W
Operating Temperature	T_{OPR}	- 40 ~ + 70	°C
Storage Temperature	T_{STG}	- 55 ~ + 125	°C

ELECTRICAL CHARACTERISTICS

(Refer to the test circuits, $I_L = 15 \sim 100\text{mA}$, $f = 200 \sim 3.4\text{KHz}$, $T_a = 25^\circ\text{C}$, unless otherwise specified)

Characteristic	Symbol	Test Conditions	Test Fig	Min	Typ	Max	Unit	
Line Voltage	V_L	$I_L = 15\text{mA}$		3.3	3.7	4.1	V	
		$I_L = 100\text{mA}$		11	13	15		
T_X Gain	$G_{V(TX)}$	$V_{MI} = 5\text{mV}$ $f = 1\text{KHz}$	4	$I_L = 20\text{mA}$	46	48	50	dB
				$I_L = 38.5\text{mA}$	43.5	45.5	47.5	
				$I_L = 55\text{mA}$	41	43	45	
T_X Range of Regulation	ΔG_{TX}	$\Delta G_{TX} = G_{TX1} - G_{TX3}$		3	5	7	dB	
T_X Frequency Response	$\Delta G_{TX(RES)}$	$V_{MI} = 5\text{mV}$ $I_L = 20\text{mA}$	4	$f = 200\text{Hz}$	-	-	± 1	dB
				$f = 3.4\text{KHz}$	-	-	± 1	
		$V_{MI} = 5\text{mV}$ $I_L = 80\text{mA}$	4	$f = 200\text{Hz}$	-	-	± 1	
				$f = 3.4\text{KHz}$	-	-	± 1	
T_X Dynamic Output Voltage	$V_{O(TX)}$	$I_L = 20\text{mA}$, $f = 200\text{Hz} \sim 3.4\text{KHz}$	4	-	1.5	-	Vp-p	
		$I_L = 100\text{mA}$, $f = 200\text{Hz} \sim 3.4\text{KHz}$		-	1.5	-		
T_X Max Output Voltage	$V_{OTX(MAX)}$	$I_L = 20\text{mA}$, $f = 200\text{Hz} \sim 3.4\text{KHz}$	4	-	1.5	-	Vp-p	
		$I_L = 100\text{mA}$, $f = 200\text{Hz} \sim 3.4\text{KHz}$		-	1.5	-		
T_X Input Impedance	$Z_{I(TX)}$	$I_L = 20\text{mA}$, $f = 200\text{Hz} \sim 3.4\text{KHz}$		-	1.7	-	K Ω	
Mute Input Current	$I_{I(MUTE)}$	$I_L = 20\text{mA}$		0.1	-	-	mA	
R_X Gain	$G_{V(RX)}$	$V_{RI} = 0.5\text{V}$ $f = 1\text{KHz}$	5	$I_L = 20\text{mA}$	-13.5	-11.5	-9.5	dB
				$I_L = 38.5\text{mA}$	-16	-14	-12	
				$I_L = 55\text{mA}$	-18.5	-16.5	-14.5	
R_X Range of Regulation	ΔG_{RX}	$\Delta G_{RX} = G_{RX1} - G_{RX3}$		3	5	7	dB	
R_X Frequency Response	$\Delta G_{RX(RES)}$	$V_{RI} = 0.5\text{V}$ $I_L = 20\text{mA}$	5	$f = 200\text{Hz}$	-	-	± 1	dB
				$f = 3.4\text{KHz}$	-	-	± 1	
		$V_{RI} = 0.5\text{V}$ $I_L = 80\text{mA}$	5	$f = 200\text{Hz}$	-	-	± 1	
				$f = 3.4\text{KHz}$	-	-	± 1	
R_X Dynamic Output Voltage	$V_{O(RX)}$	$I_L = 20\text{mA}$	5	$f = 200\text{Hz}$	0.3	0.5	-	Vp-p
				$f = 3.4\text{KHz}$	0.3	0.5	-	
		$I_L = 100\text{mA}$	5	$f = 200\text{Hz}$	0.3	0.5	-	
				$f = 3.4\text{KHz}$	0.3	0.5	-	
R_X Max Output Voltage	$V_{ORX(MAX)}$	$I_L = 20\text{mA}$	5	$f = 200\text{Hz}$	-	0.9	-	Vp-p
		$V_{RI} = 10\text{V}$		$f = 3.4\text{KHz}$	-	0.9	-	

KA8503

LOW VOLTAGE SPEECH NETWORK

TEST CIRCUIT

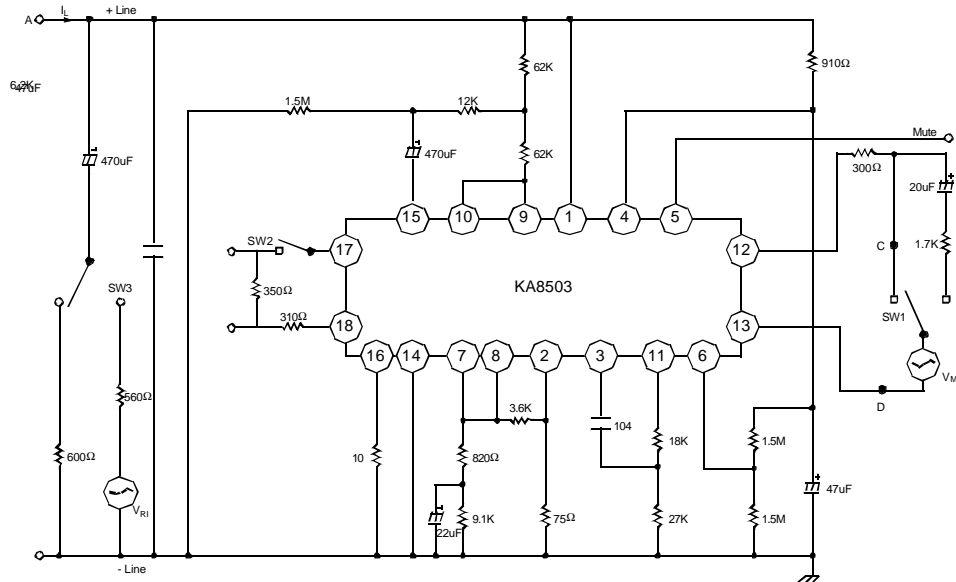

Fig. 3

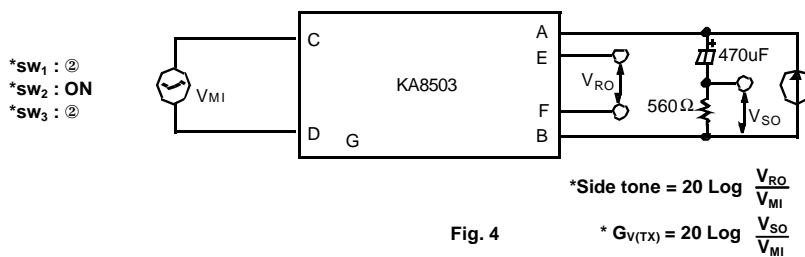

Fig. 4

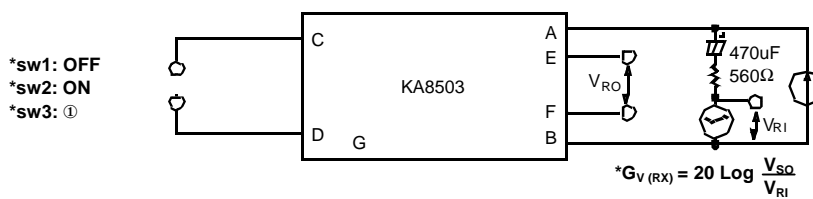
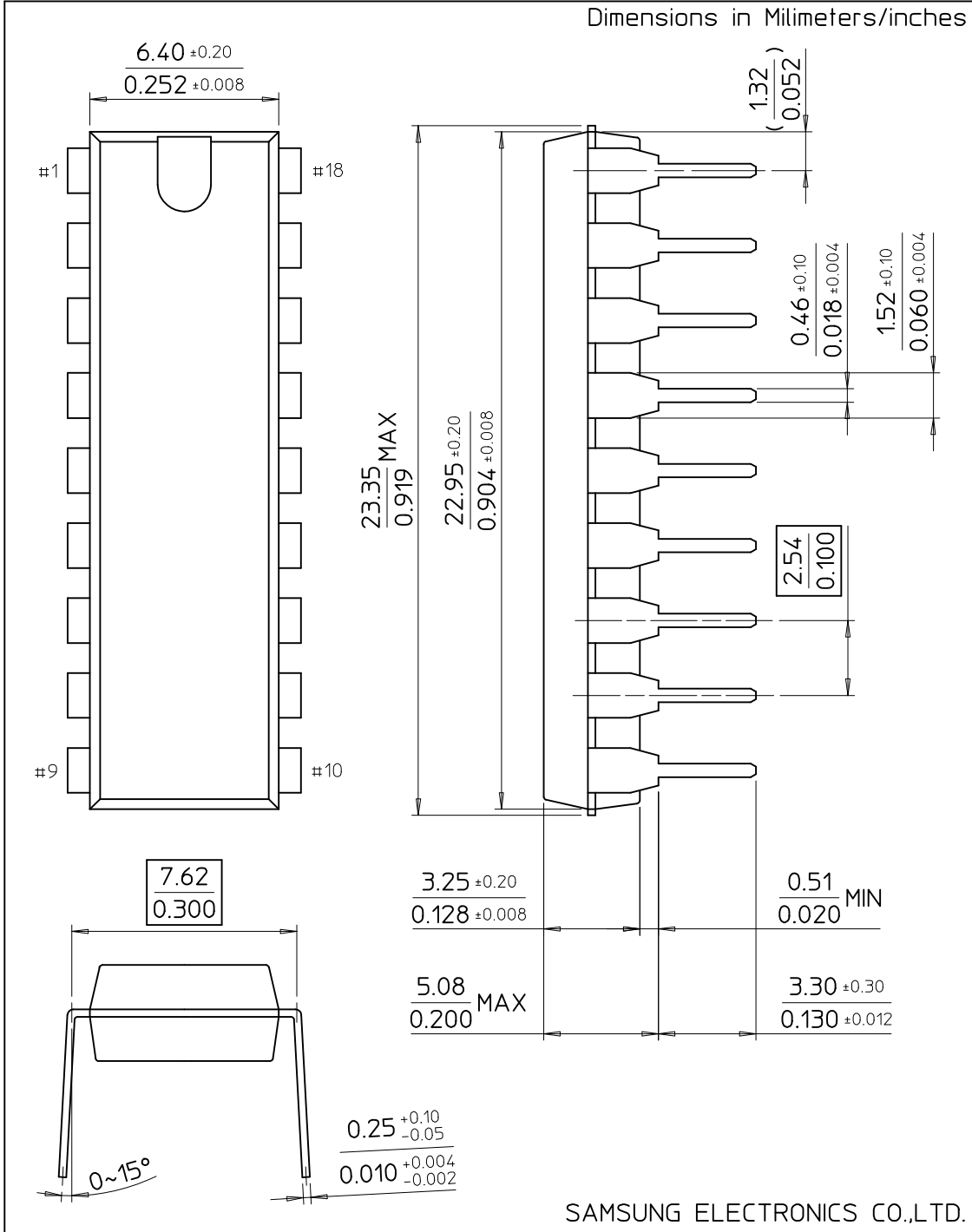

Fig. 5

18-DIP-300A

Dimensions in Millimeters/inches



SAMSUNG ELECTRONICS CO.,LTD.