

Fundamental AT-Cut Quartz Crystal

DESCRIPTION

The CX103 quartz crystal is a high quality miniature AT cut quartz resonator. The CX103 is hermetically sealed in a rugged, miniature ceramic package, one-fourth the size of an eight-pin mini-DIP. The CX103 crystal is manufactured using the STATEK-developed photolithographic process, and was designed utilizing the experience acquired by producing millions of crystals for industrial, commercial, military and medical applications.

FEATURES

- Low-profile hermetically-sealed package
- Excellent aging characteristics
- High shock resistance
- Full military testing available
- Designed and manufactured in the USA

PACKAGE HANDLING

The CX crystal is hermetically sealed in a ceramic package. Normal handling and soldering precautions for small, low thermal mass parts are adequate when installing or testing CX crystals. CX crystals may be wave soldered, with proper precaution taken to avoid desoldering the leads. A slow machine rate or too high a pre-heat temperature or solder bath temperature can damage the crystals. **Lead to package solder interface temperature should not exceed 175°C, glass lid to package seal rim temperature should not exceed 210°C.** If the seal rim reaches temperatures above the maximum specified, the package may lose its hermeticity resulting in degradation of crystal performance. Mishandling of CX crystals can cause cracking of the glass lid and loss of hermeticity.

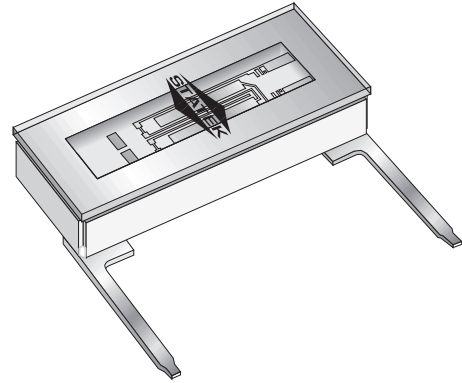

PACKAGE DIMENSIONS

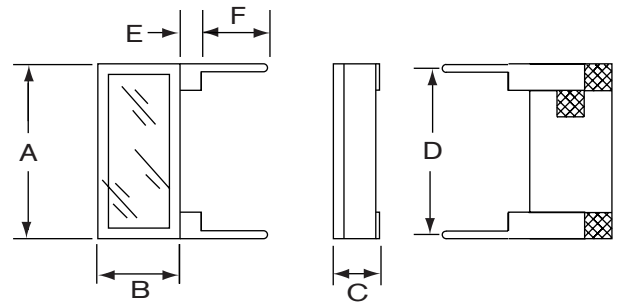

DIM	TYP.		MAX.	
	INCHES	mm	INCHES	mm
A	0.315	8.00	0.330	8.38
B	0.140	3.56	0.155	3.94
C	0.070	1.78	0.080	2.03
D	0.300	7.62	0.310	7.87
E	0.020	0.51	0.040	1.02
F	0.150	3.81	0.160	4.06

Leads 0.013" x 0.018" (0.33 x 0.46 mm) typical.

EQUIVALENT CIRCUIT

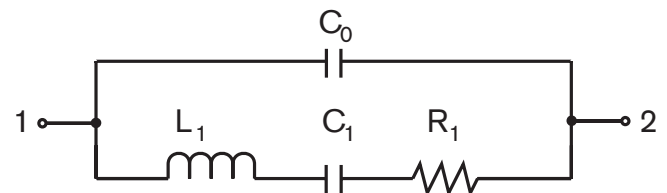

R₁ Motional Resistance L₁ Motional Inductance
 C₁ Motional Capacitance C₀ Shunt Capacitance

SPECIFICATIONS

Specifications are typical at 25°C unless otherwise noted.
Specifications are subject to change without notice.

Parameters	Fundamental				Overtone	
	555 k	614 k	1.0 M	1.4 M	1.8432 M	2.1 M
Frequency Range, (Hz)	555 k	614 k	1.0 M	1.4 M	1.8432 M	2.1 M
Motional Resistance, R_1 (Ω)	600	275	500	775	300	475
Motional Resistance, R_1 MAX	3 k Ω					
Motional Capacitance, C_1 (fF)	2.5	3.6	2.0	1.5	2.8	2.6
Quality Factor, Q (k)	170	260	190	100	110	70
Shunt Capacitance, C_0 (pF)	1.2	1.3	1.1	1.0	1.3	1.3

Calibration Tolerance¹ \pm 500 ppm (0.05%)
 \pm 1000 ppm (0.1%)
 \pm 10000 ppm (1.0%)

Drive Level 3 μ W MAX

Load Capacitance² 7 pF

Turning Point (T_0)² 35°C

Temperature Coefficient (k) -0.035 ppm/°C²

Note: Frequency f at temperature T is related to frequency f_0 at turning point temperature T_0 by: $\frac{f-f_0}{f_0} = k(T-T_0)^2$

Function Mode Extensional
 Aging, first year 5 ppm MAX
 Shock, survival 750 g, 0.3 ms, 1/2 sine
 Vibration, survival 10 g RMS, 20-1,000 Hz random
 Operating Temp. Range -10°C to +70°C (Commercial)
 -40°C to +85°C (Industrial)
 -55°C to +125°C (Military)
 Storage Temp. Range -55°C to +125°C
 Max Process Temperature 260°C for 20 sec.

1. Tighter tolerances available.

2. Other values available.

HOW TO ORDER CX103 LEADED CRYSTAL

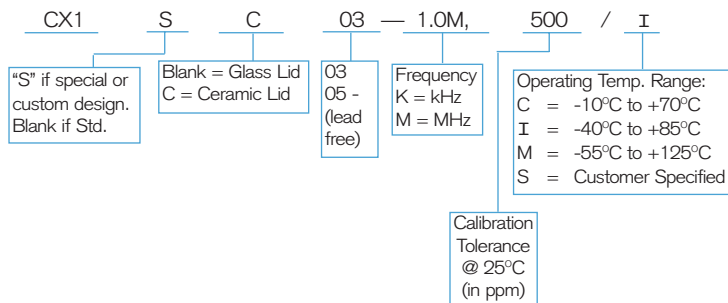

PACKAGING

Tray Pack

TYPICAL APPLICATION FOR A PIERCE OSCILLATOR

The low profile CX miniature leaded crystal is ideal for small, high density, battery operated portable products. The CX crystal designed in a Pierce oscillator (single inverter) circuit provides very low current consumption and high stability. A conventional CMOS Pierce oscillator circuit is shown below. The crystal is effectively inductive and in a PI-network circuit with C_D and C_G provides the additional phase shift necessary to sustain oscillation. The oscillation frequency (f_0) is 15 to 150 ppm above the crystal's series resonant frequency (f_s).

Drive Level

R_A is used to limit the crystal's drive level by forming a voltage divider between R_A and C_D . R_A also stabilizes the oscillator against changes in the amplifiers output resistance (R_O). R_A should be increased for higher voltage operation.

Load Capacitance

The CX crystal calibration tolerance is influenced by the effective circuit capacitances, specified as the load capacitance (C_L). C_L is approximately equal to:

$$C_L = \frac{C_D \times C_G}{C_D + C_G} + C_S \quad (1)$$

NOTE: C_D and C_G include stray layout to ground and C_S is the stray shunt capacitance between the crystal terminal. In practice, the effective value of C_L will be less than that calculated from C_D , C_G and C_S values because of the effect of the amplifier output resistance. C_S should be minimized.

The oscillation frequency (f_0) is approximately equal to:

$$f_0 = f_s \left[1 + \frac{C_1}{2(C_0 + C_L)} \right] \quad (2)$$

Where f_s = Series resonant frequency of the crystal
 C_1 = Motional Capacitance
 C_0 = Shunt Capacitance

CONVENTIONAL CMOS PIERCE OSCILLATOR CIRCUIT

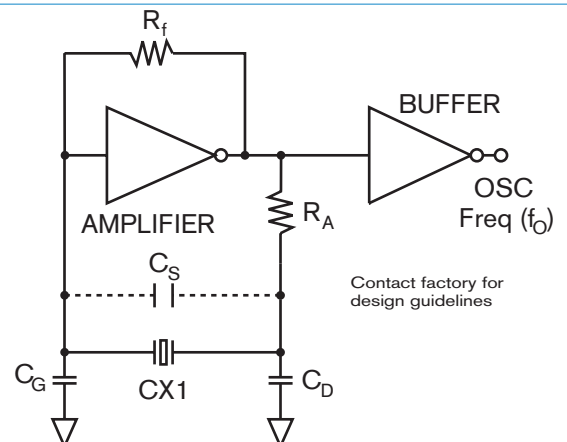

10130 - Rev E