



± 2g Tri-axis Analog Accelerometer Specifications

PART NUMBER:

KXTC9-4100
Rev. 1
Jan-2011

Product Description

The KXTC9-4100 is a Tri-axis, silicon micromachined accelerometer with a full-scale output range of +/-2g (19.6 m/s/s). The sense element is fabricated using Kionix's proprietary plasma micromachining process technology. Acceleration sensing is based on the principle of a differential capacitance arising from acceleration-induced motion of the sense element, which further utilizes common mode cancellation to decrease errors from process variation, temperature, and environmental stress. The sense element is hermetically sealed at the wafer level by bonding a second silicon lid wafer to the device using a glass frit. A separate ASIC device packaged with the sense element provides signal conditioning and self-test. The accelerometer is delivered in a 3 x 3 x 0.9mm Land Grid Array (LGA) plastic package operating from a 1.8 – 3.6V DC supply. The KXTC9 features a factory programmable low pass filter.



There are 2 factory programmable modes of operation for the KXTC9:

Mode 00 – The Enable pin must be **high** for normal operation and **low** for power shutdown.

Mode 01 – The Enable pin must be **low** for normal operation and **high** for power shutdown.

The KXTC9-4100 is factory programmed to be in MODE 00.



± 2g Tri-axis Analog Accelerometer Specifications

PART NUMBER:

KXTC9-4100
Rev. 1
Jan-2011

Functional Diagram

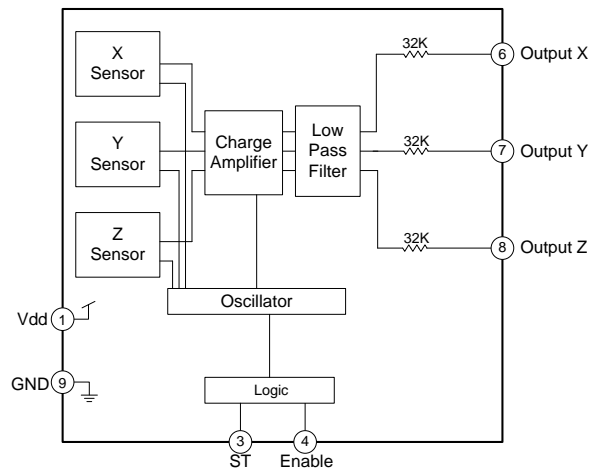



± 2g Tri-axis Analog Accelerometer Specifications

PART NUMBER:

**KXTC9-4100
Rev. 1
Jan-2011**

Product Specifications

Table 1. Mechanical

(specifications are for operation at 1.8V and T = 25C unless stated otherwise)

Parameters	Units	Min	Typical	Max
Operating Temperature Range	°C	-40	-	85
Zero-g Offset	V	0.855	0.9	0.945
Zero-g Offset Variation from RT over Temp.	mg/°C		0.7 (xy) 0.4 (z)	
Sensitivity	mV/g	349	360	371
Sensitivity Variation from RT over Temp.	%/°C		0.01 (xy) 0.04 (z)	
Offset Ratiometric Error ($V_{dd} = 1.8V \pm 5\%$)	%		0.2	
Sensitivity Ratiometric Error ($V_{dd} = 1.8V \pm 5\%$)	%		0.3 (xy) 0.15 (z)	
Self Test Output change on Activation	g		0.8 (x) 0.7 (y) 0.5 (z)	
Mechanical Resonance (-3dB) ¹	Hz		3500 (xy) 1800 (z)	
Non-Linearity	% of FS		0.1	
Cross Axis Sensitivity	%		2	
Noise Density (on filter pins)	μg / √Hz		125	

Notes:

1. Resonance as defined by the dampened mechanical sensor.



± 2g Tri-axis Analog Accelerometer Specifications

PART NUMBER:

KXTC9-4100
Rev. 1
Jan-2011

Table 2. Electrical

(specifications are for operation at 1.8V and T = 25C unless stated otherwise)

Parameters		Units	Min	Typical	Max
Supply Voltage (V _{dd})	Operating	V	1.7	1.8	3.6
Current Consumption	Operating (full power)	μA	170	240	310
	Standby	μA		5	
Analog Output Resistance(R _{out})		kΩ	24	32	40
Power Up Time ¹		ms	-	5*R _{out} *C	-
Bandwidth (-3dB) ²		Hz	40	50	60

Notes:

1. Power up time is determined by 5 times the RC time constant of the factory programmed or user defined low pass filter.
2. Factory programmable to have a switched capacitor low pass filter at 2kHz, 1kHz, 500Hz, 100Hz, 50Hz, or no low pass filter. Optionally, the user can define with external capacitors. Maximum defined by the frequency response of the sensors.



± 2g Tri-axis Analog Accelerometer Specifications

PART NUMBER:

KXTC9-4100
Rev. 1
Jan-2011

Table 3. Environmental

Parameters		Units	Min	Typical	Max
Supply Voltage (V _{dd})	Absolute Limits	V	-0.3	-	6.0
Operating Temperature Range		°C	-40	-	85
Storage Temperature Range		°C	-55	-	150
Mech. Shock (powered and unpowered)		g	-	-	5000 for 0.5ms 10000 for 0.2ms
ESD	HBM	V	-	-	2000



Caution: ESD Sensitive and Mechanical Shock Sensitive Component, improper handling can cause permanent damage to the device.



This product conforms to Directive 2002/95/EC of the European Parliament and of the Council of the European Union (RoHS). Specifically, this product does not contain lead, mercury, cadmium, hexavalent chromium, polybrominated biphenyls (PBB), or polybrominated diphenyl ethers (PBDE) above the maximum concentration values (MCV) by weight in any of its homogenous materials. Homogenous materials are "of uniform composition throughout."



This product is halogen-free per IEC 61249-2-21. Specifically, the materials used in this product contain a maximum total halogen content of 1500 ppm with less than 900-ppm bromine and less than 900-ppm chlorine.

Soldering

Soldering recommendations are available upon request or from www.kionix.com.



± 2g Tri-axis Analog Accelerometer Specifications

PART NUMBER:
KXTC9-4100
 Rev. 1
 Jan-2011

Application Schematic

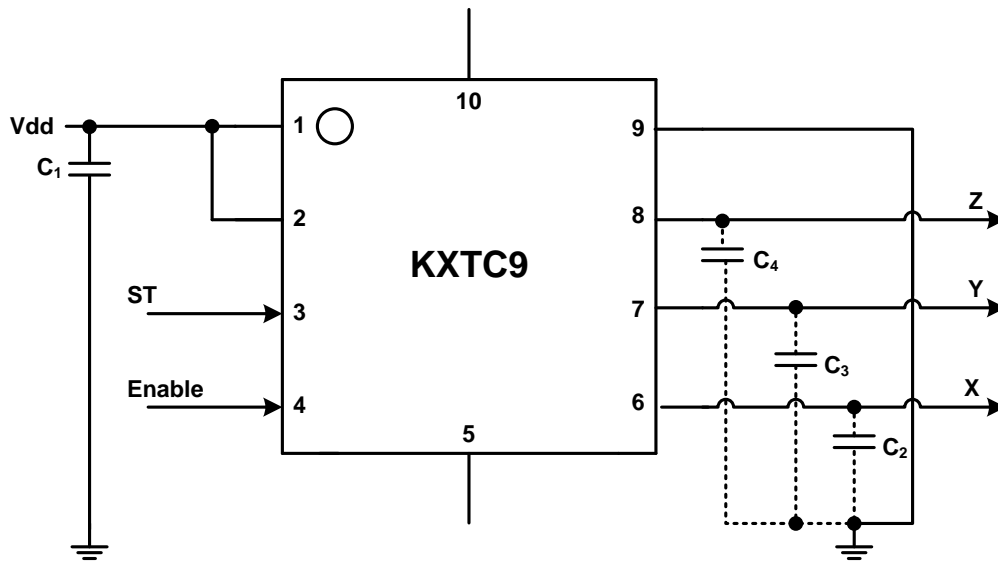

Table 4. KXTC9 Pin Descriptions

Pin	Name	Description
1	Vdd	The power supply input. Decouple this pin to ground with a 0.1uF ceramic capacitor (C ₁).
2	Res	Reserved – Connect to Vdd or Ground
3	ST	Self Test: Low - Normal operation; High - Device is in self-test mode. Connect to Ground if not used.
4	Enable	Enable (1 = Enabled, 0 = Disabled)
5	NC	Not Connected Internally – may be connected to Vdd or Ground
6	X Output	Analog output of the x-channel. Optionally, a capacitor (C ₂) placed between this pin and ground will form a low pass filter.
7	Y Output	Analog output of y-channel. Optionally, a capacitor (C ₃) placed between this pin and ground will form a low pass filter.
8	Z Output	Analog output of z-channel. Optionally, a capacitor (C ₄) placed between this pin and ground will form a low pass filter.
9	GND	Ground
10	NC	Not Connected Internally – may be connected to Vdd or Ground

Application Design Equations

The bandwidth is determined by a factory programmable switched capacitor filter. The filter can be set at the factory to be 2kHz, 1kHz, 500Hz, 100Hz, 50Hz, or no low pass filter. Alternatively, bandwidth can be reduced by addition of a capacitor on the output pins 5, 6, and 7 according to the equation:

$$C_2 = C_3 = C_4 = \frac{4.97 \times 10^{-6}}{f_{BW}}$$



± 2g Tri-axis Analog Accelerometer Specifications

PART NUMBER:

KXTC9-4100
Rev. 1
Jan-2011

Test Specifications



Special Characteristics:

These characteristics have been identified as being critical to the customer. Every part is tested to verify its conformance to specification prior to shipment.

Table 5. Test Specifications

Parameter	Specification	Test Conditions
Zero-g Offset @ RT	0.9 +/- 0.045 V	25C, Vdd = 1.8 V
Sensitivity @ RT	360 +/- 11 mV/g	25C, Vdd = 1.8 V
Current Consumption -- Operating	170 <= Idd <= 310 uA	25C, Vdd = 1.8 V



± 2g Tri-axis Analog Accelerometer Specifications

PART NUMBER:
KXTC9-4100
Rev. 1
Jan-2011

Package Dimensions and Orientation

3 x 3 x 0.9 mm LGA

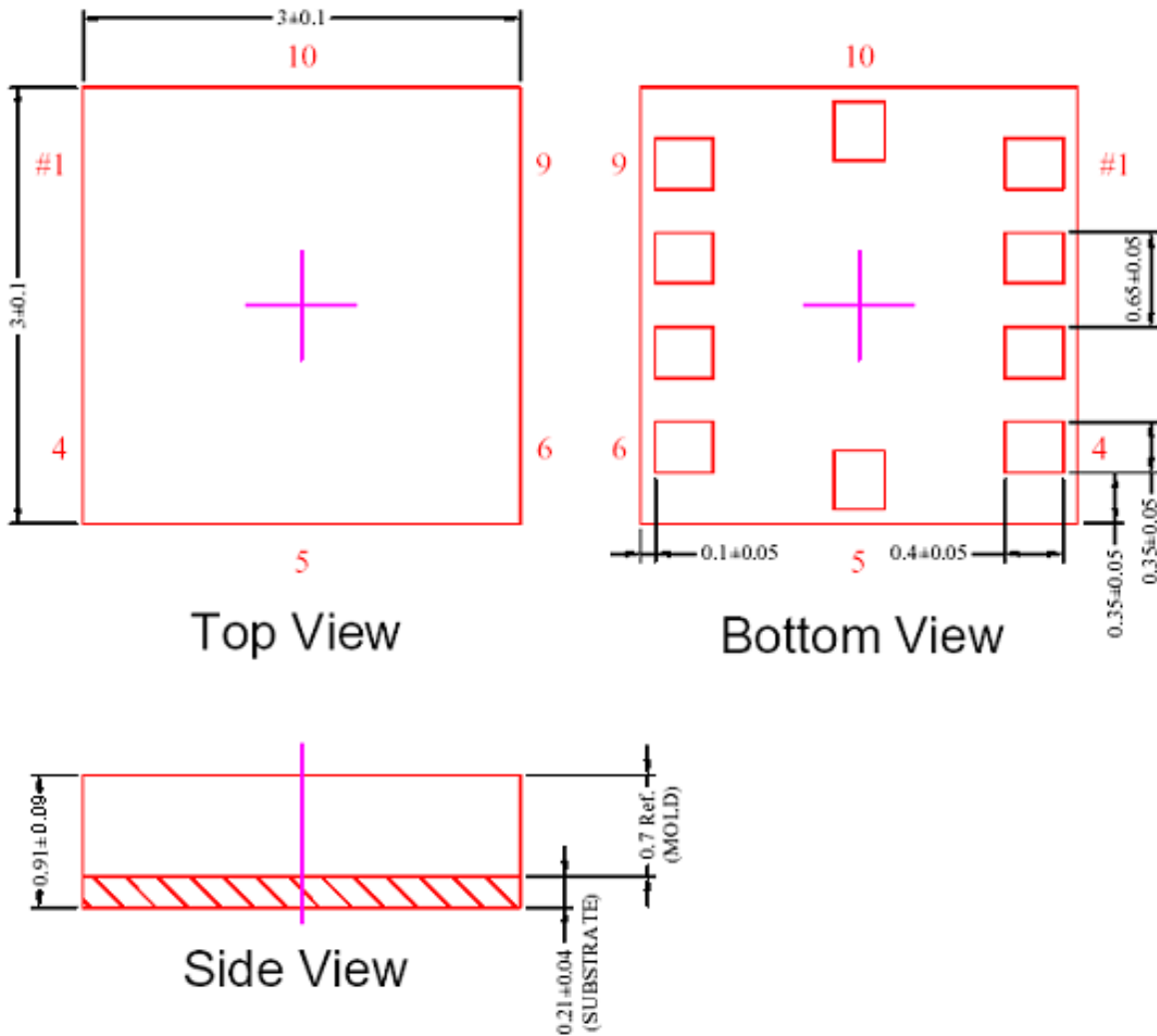

All dimensions and tolerances conform to ASME Y14.5M-1994



± 2g Tri-axis Analog Accelerometer Specifications

PART NUMBER:
KXTC9-4100
Rev. 1
Jan-2011

Static X/Y/Z Output Response versus Orientation to Earth's surface (1-g):

Position	1	2	3	4	5	6
Diagram						
X	0.9 V	1.26 V	0.9 V	0.54 V	0.9 V	0.9 V
Y	1.26 V	0.9 V	0.54 V	0.9 V	0.9 V	0.9 V
Z	0.9 V	0.9 V	0.9 V	0.9 V	1.26 V	0.54 V
X-Polarity	0	+	0	-	0	0
Y-Polarity	+	0	-	0	0	0
Z-Polarity	0	0	0	0	+	-

↓ (1-g)

Earth's Surface



± 2g Tri-axis Analog Accelerometer Specifications

PART NUMBER:

**KXTC9-4100
Rev. 1
Jan-2011**

Revision History

REVISION	DESCRIPTION	DATE
1	Initial product release	24-Jan-2011

"Kionix" is a registered trademark of Kionix, Inc. Products described herein are protected by patents issued or pending. No license is granted by implication or otherwise under any patent or other rights of Kionix. The information contained herein is believed to be accurate and reliable but is not guaranteed. Kionix does not assume responsibility for its use or distribution. Kionix also reserves the right to change product specifications or discontinue this product at any time without prior notice. This publication supersedes and replaces all information previously supplied.

Mouser Electronics

Authorized Distributor

Click to View Pricing, Inventory, Delivery & Lifecycle Information:

[Kionix:](#)

[KXTC9-4100](#)