

PNP General Purpose Transistors

 Lead(Pb)-Free

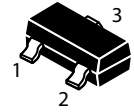
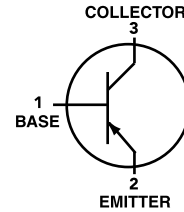

SOT-23

MAXIMUM RATINGS(T_a=25°C)

Rating	Symbol	Value	Unit
Collector-Emitter Voltage	V _{CEO}	-45	V
Collector-Base Voltage	V _{CBO}	-60	V
Emitter-Base Voltage	V _{EBO}	-7.0	V
Collector Current - Continuous	I _C	-100	mA
Collector Current - Peak	I _{C(P)}	-200	mA
Total Device Dissipation T _A =25°C	P _D	0.2	mW
Junction Temperature	T _j	+150	°C
Storage Temperature	T _{stg}	-55 to +150	°C

Device Marking

MSB709=AR

ELECTRICAL CHARACTERISTICS

Characteristics	Symbol	Min	Typ	Max	Unit
Collector-Emitter Breakdown Voltage $I_C = -2.0\text{mA}, I_E = 0\text{A}$	$V_{(BR)CEO}$	-45	-	-	V
Collector-Base Breakdown Voltage $I_C = -10\mu\text{A}, I_B = 0\text{A}$	$V_{(BR)CBO}$	-60	-	-	V
Emitter-Base Breakdown Voltage $I_E = 10\mu\text{A}, I_C = 0$	$V_{(BR)EBO}$	-7.0	-	-	V
Collector Cutoff Current $V_{CB} = -45\text{V}, I_C = 0\text{A}$	I_{CBO}	-	-	0.1	μA
Emitter Cutoff Current $V_{EB} = -10\text{V}, I_C = 0\text{A}$	I_{CEO}	-	-	0.1	μA

ON CHARACTERISTICS

Collector-Emitter Saturation Voltage $I_C = -100\text{mA}, I_B = -10\text{mA}$	$V_{CE(sat)}$	-	-	-0.5	V
DC Current Transfer Ratio ¹ $V_{CE} = -10\text{V}, I_C = -20\text{mA}$	h_{FE}	210	-	340	V

1. Pulse Test : Pulse Width $\leq 300\mu\text{s}$, D.C. $\leq 2\%$

SOT-23 Outline Dimension

Unit:mm

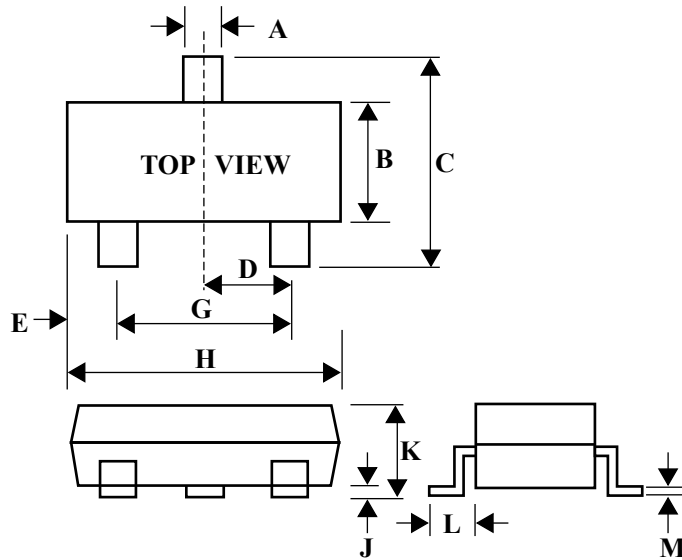

SOT-23		
Dim	Min	Max
A	0.35	0.51
B	1.19	1.40
C	2.10	3.00
D	0.85	1.05
E	0.46	1.00
G	1.70	2.10
H	2.70	3.10
J	0.01	0.13
K	0.89	1.10
L	0.30	0.61
M	0.076	0.25

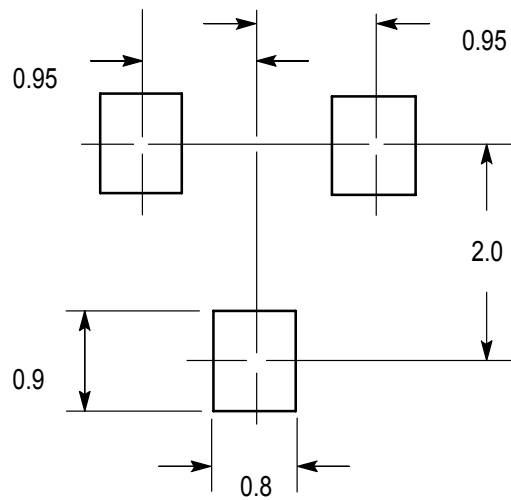

Tape & Reel and Packaging Specifications for Small-Signal Transistors, FETs and Diodes

Embossed Tape and Reel is used to facilitate automatic pick and place equipment feed requirements. The tape is used as the shipping container for various products and requires a minimum of handling. The antistatic/conductive tape provides a secure cavity for the product when sealed with the “peel-back” cover tape.

- Two Reel Sizes Available (7" and 13")
- Used for Automatic Pick and Place Feed Systems
- Minimizes Product Handling
- EIA 481, -1, -2
- SOT-23, SC-70/SOT-323,
- SC-89, SC-88/SOT-363, SC-88A/SOT-353,
- SOD-323, SOD-523 in 8 mm Tape

Use the standard device title and add the required suffix as listed in the option table below (Table 1). Note that the individual reels have a finite number of devices depending on the type of product contained in the tape. Also note the minimum lot size is one full reel for each line item, and orders are required to be in increments of the single reel quantity.

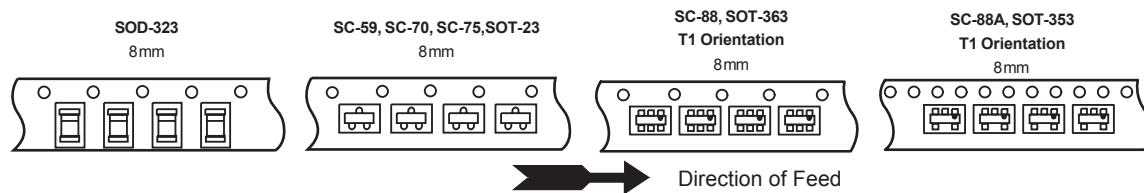

Typical Reel Orientations

Table 1. EMBOSSED TAPE AND REEL ORDERING INFORMATION

Package	Tape Width (mm)	Pitch mm	Reel Size mm(inch)	Devices Per Reel and Minimum Order Quantity	Device Suffix
SOT-23	8	4	178	(7)	3,000
	8	4	330	(13)	10,000
SC-70/SOT-323	8	4	178	(7)	3,000
	8	4	330	(13)	10,000
SC-89	8	4	178	(7)	3,000
	8	4	330	(13)	10,000
SC-88/SOT-363	8	4	178	(7)	3,000
	8	4	330	(13)	10,000
SC-88A/SOT-353	8	4	178	(7)	3,000
	8	4	330	(13)	10,000
SOD-323	8	4	178	(7)	3,000
	8	4	330	(13)	10,000
SOD-523	8	4	178	(7)	3,000
	8	4	330	(13)	10,000

EMBOSSED TAPE AND REEL DATA FOR DISCRETES CARRIER TAPE SPECIFICATIONS

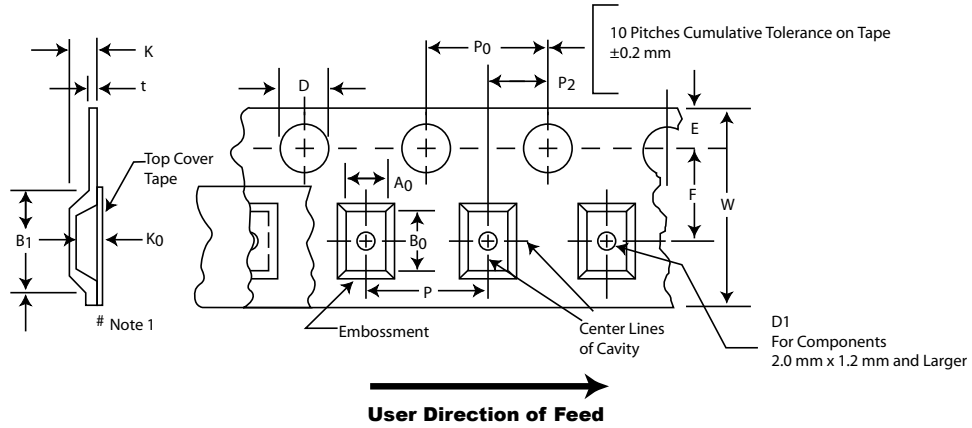

FOR MACHINE REFERENCE ONLY⁰
INCLUDING DRAFT AND RADII
CONCENTRIC AROUND B_0

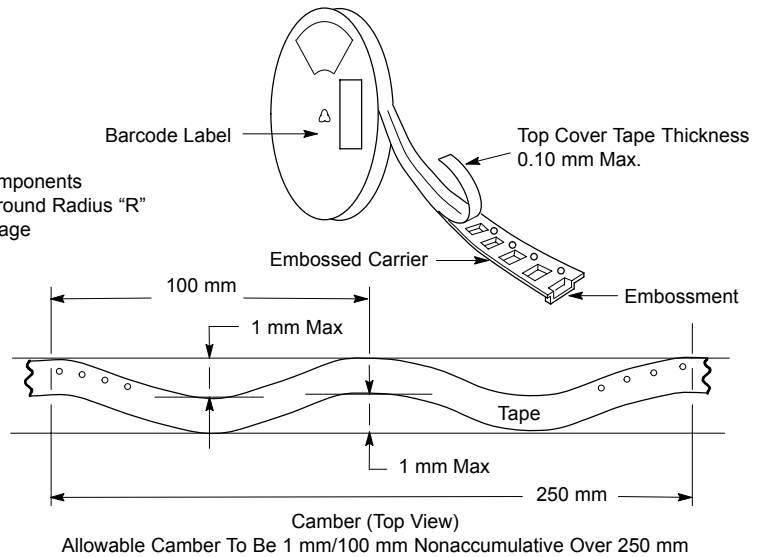
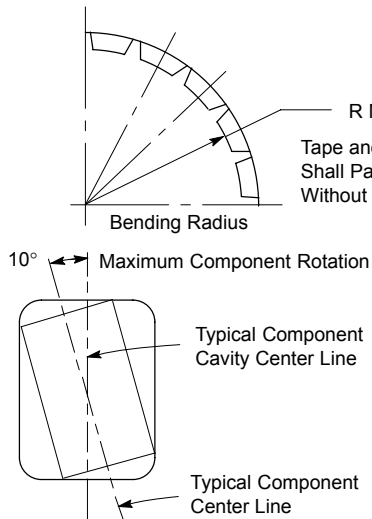

DIMENSIONS

Size	B1 Max #(Note 2)	D	D1	E	F	K	P ₀	P ₂	R Min	T Max	W Max	
8mm	4.55 mm	1.5+0.1 mm -0.0	1.0 Min	1.75±0.1 mm	3.5±0.05 mm	2.4 mm Max	4.0±0.1 mm	2.0±0.1 mm	25 mm	0.6 mm	8.3 mm	
12mm	8.2 mm		1.5 mm Min		5.5±0.05 mm	6.4 mm Max					30 mm	12±0.3 mm
16mm	12.1 mm				7.5±0.10 mm	7.9 mm Max					16.3 mm	
24mm	20.1 mm				11.5±0.1 mm	11.9 mm Max					24.3 mm	

Metric dimensions govern - English are in parentheses for reference only.

NOTE 1: A_0 , B_0 , and K_0 are determined by component size. The clearance between the components and the cavity must be within .05 mm min. to .50 mm max.,

NOTE 2: the component cannot rotate more than 10° within the determined cavity.

NOTE 3: If B_1 exceeds 4.2 mm for 8 mm embossed tape, the tape may not feed through all tape feeders.

EMBOSSED TAPE AND REEL DATA FOR DISCRETES

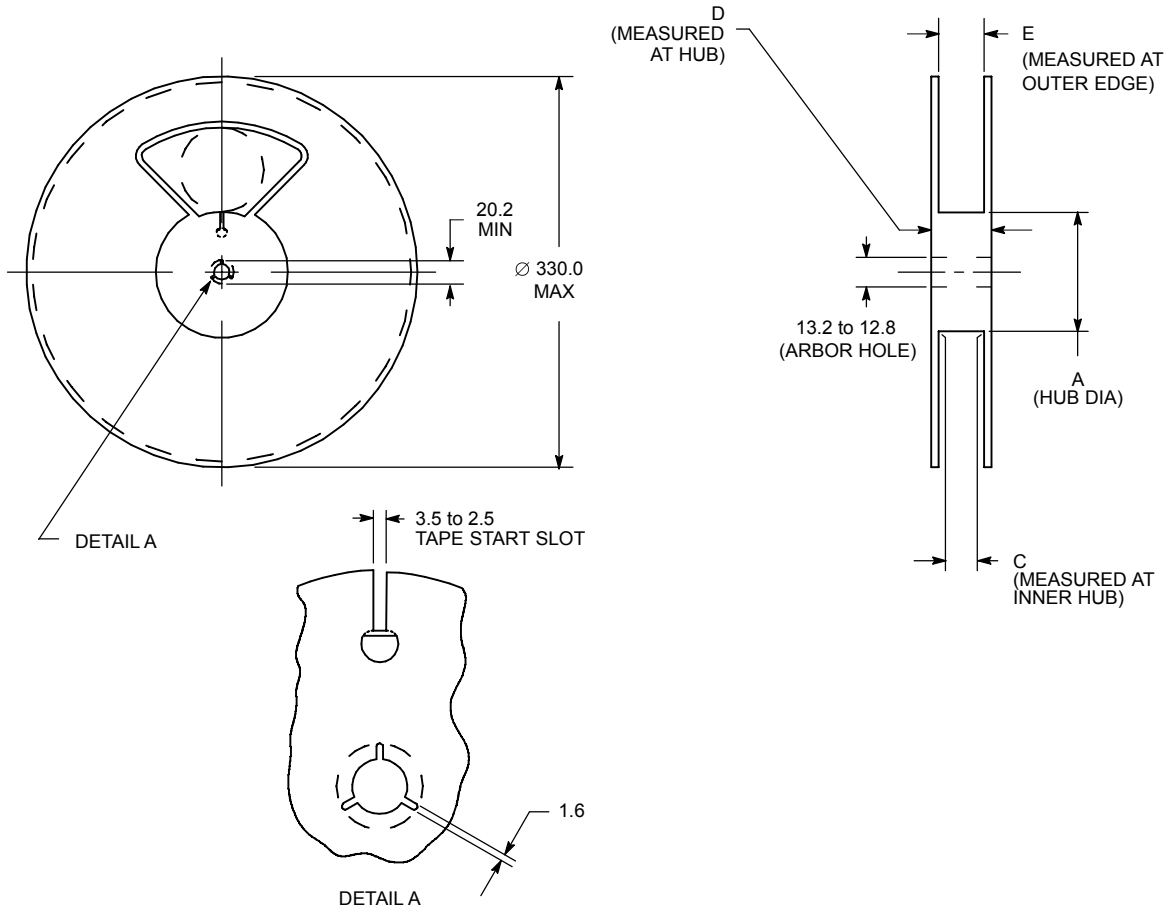

Reel Diameter	Tape Size	A		C		D (Max)	E (Max)
		Min	Max	Min	Max		
178.0	8.0	50.0	-	8.4	9.9	14.4	10.9
330.0	8.0	50.0	-	8.4	9.9	14.4	10.9

Reel Dimensions

Metric Dimensions Govern - English are in parentheses for reference only

Storage Conditions

Temperature: 5 to 40 Deg.C (20 to 30 Deg. C is preferred) Humidity: 30 to 80 RH (40 to 60 is preferred)
 Recommended Period: One year after manufacturing (This recommended period is for the soldering condition only. The characteristics and reliabilities of the products are not restricted to this limitation)