

AN7463S

FM Noise Canceller/Stereo Multiplex Demodulator for Car Radio

Overview

The AN7463S is an integrated circuit for car stereo configured FM noise canceller and PLL multiplex demodulator in a single chip. It is the same function/performance/pin compatible as the AN7465S except for ASC · ATC characteristics.

Features

- HPF/LPF of noise canceller input section built-in.
- Good S/N and distortion by using quasi sine wave as pilot canceller negative wave.
- HPF band width auto switching by monaural and stereo.
- With ASC · ATC functions reducing noise at weak electric field smoothly.
- With forced monaural and VCO stop functions

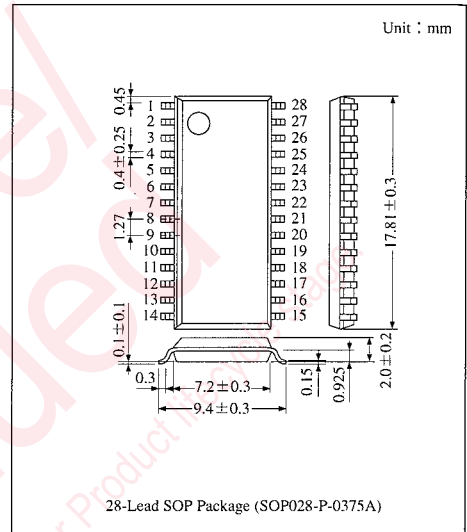

Block Diagram

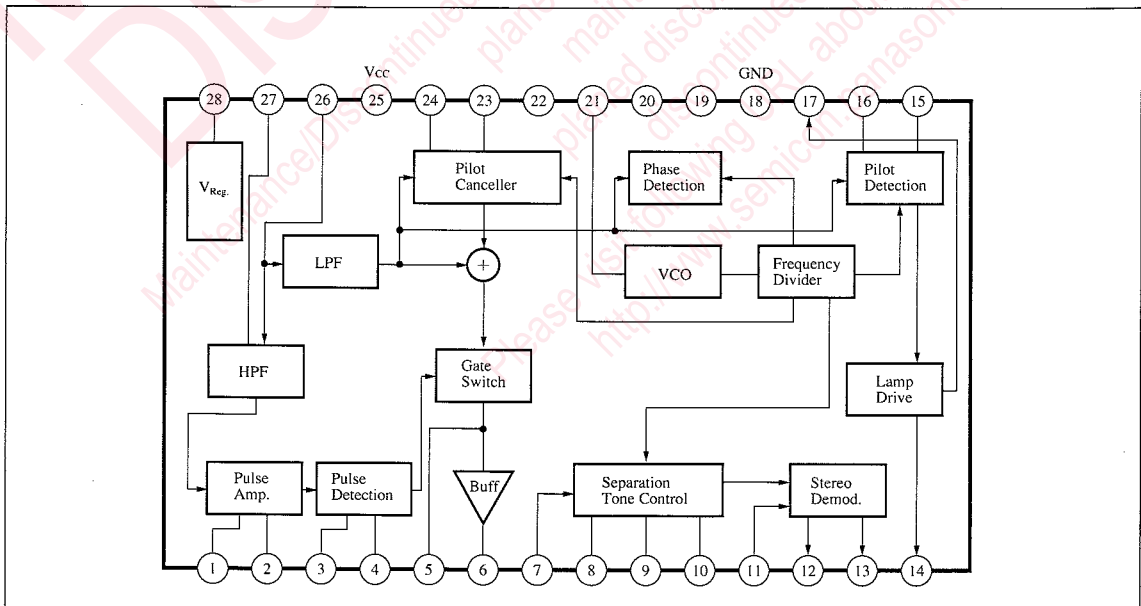

■ Absolute Maximum Ratings (Ta=25°C)

Parameter		Symbol	Rating	Unit
Supply Voltage		V _{CC}	10	V
Supply Current	Without Lamp Current	I _{CC(1)}	25	mA
	With Lamp Current	I _{CC(2)}	30	mA
Power Dissipation		P _D	280	mW
Operating Ambient Temperature		T _{opr}	-30 ~ +75	°C
Storage Temperature		T _{stg}	-55 ~ +125	°C

■ Recommended Operating Range (Ta=25°C)

Parameter	Symbol	Range
Operating Supply Voltage Range	V _{CC}	6V ~ 10V

■ Electrical Characteristics (Ta=25°C)

Parameter	Symbol	Condition	min.	typ.	max.	Unit
Total Circuit Current	I _{tot}	V _{in} =0mVrms	10	15	20	mA
AGC Voltage (1)	V _{AGC1}	V _{in} =0mVrms, R _S =10kΩ	—	0.05	0.4	V
AGC Voltage (2)	V _{AGC2}	V _{in} =2mVrms, f=150kHz	1	1.3	1.5	V
Noise Detection Voltage	V _{Det.}	V _{in} =100mVrms, f=150kHz	—	0.05	0.3	V
Gate Pulse Width	PW	V _{in} =0.3V _{P-P} Pulse, t _w =1μs, f=1kHz	20	25	30	μs
Residual Noise Voltage	V _{NR}	V _{in} =1V _{P-P} Pulse*, t _w =10μs, f=1kHz	—	0.3	0.7	mVrms
Output Voltage	V _O	V _{in} =300mV, f=1kHz	250	290	330	mVrms
Channel Balance	CB	V _{in} =300mV, f=1kHz	—	0	1	dB
Separation (1) (R ^⑨ =820Ω fixed)	Sep. ₁	V _{L+R} =270mV, V _P =30mV, f=1kHz	22	32	—	dB
Separation (2) (at R ^⑨ adjustment)	Sep. ₂	At V _{L+R} =270mV, V _P =30mV, f=1kHz adjustment	—	40	—	dB
THD (L+R)	THD	V _{L+R} =270mV, V _P =30mV, f=1kHz	—	0.05	0.3	%
THD (Monaural)	THD	V _{in} =300mV, f=1kHz	—	0.05	0.3	%
Residual Pilot Voltage	V _{PC}	V _P =30mV	—	2.5	10	mVrms
Lamp ON Pilot Voltage	V _{P(ON)}	Input only Pilot Signal	11	16	21	mVrms
Lamp OFF Pilot Voltage	V _{P(OFF)}	Input only Pilot Signal	—	8	—	mVrms
Capture Range	CR	V _P =30mV	±1.8	±3	—	%
VCO Stop Voltage	V ₁₄₋₁₈	Pin ^⑭ , VCO Stop Voltage	3	3.4	3.8	V
Maximum Input Voltage	V _{i(max.)}	f=1kHz, Input at lamp ON	0.7	—	—	Vrms
Input Impedance	Z _{in}	Pin ^⑳	—	53	—	kΩ
Output Impedance	Z _o	Pin ^⑫ , ^⑬	—	3.3	—	kΩ

* Input through LPF of R=150Ω, C=0.033μF.

ICs for
Tuner

■ Difference between AN7463S and AN7465S

The AN7463S is all the same as the AN7465S except for ASC/ATC control characteristics. Refer to the AN7465S for electrical characteristics and application circuit.

• ASC, ATC Characteristics Comparison

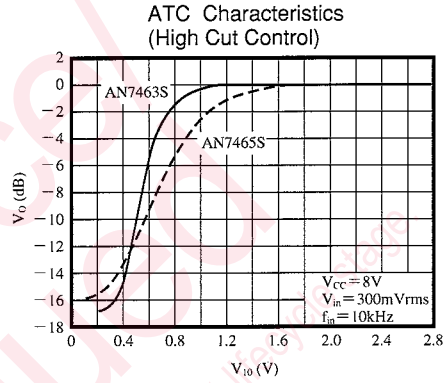
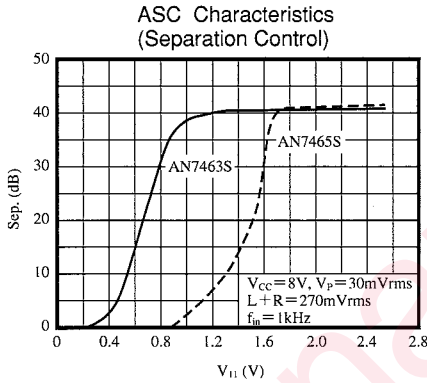

■ Supplementary Explanation

• Noise Canceller/MPX IC Series for Car Radio Comparison List

Noise canceller/MPX IC series for car radio is integrated noise canceller for FM radio and FM stereo MPX circuit on a single chip in Pin²⁸~³², which is most suitable series for cost down of high performance car radio.

Item	Type Name	AN7465S/K	AN7464S	AN7463S
Package		K···Pin ²⁸ · Shrunk DIL S···Pin ²⁸ · Flat	Pin ²⁸ · Flat	Pin ²⁸ · Flat
Supply Voltage		6V~10V	6V~10V	6V~10V
Supply Current		15mA	16mA	15mA
Noise Canceller		○	○	○
Pilot Canceller		○	○	○
ATC (Refer to above diagram)		○	○	○
ASC (Refer to above diagram)		○	○	○
Forced Manual/V/COSTOP		○	○	○
Noise Canceller HPF Switching		○	○	○
Multipath Detection Amp.		×	○	×

Request for your special attention and precautions in using the technical information and semiconductors described in this book

- (1) If any of the products or technical information described in this book is to be exported or provided to non-residents, the laws and regulations of the exporting country, especially, those with regard to security export control, must be observed.
- (2) The technical information described in this book is intended only to show the main characteristics and application circuit examples of the products. No license is granted in and to any intellectual property right or other right owned by Panasonic Corporation or any other company. Therefore, no responsibility is assumed by our company as to the infringement upon any such right owned by any other company which may arise as a result of the use of technical information described in this book.
- (3) The products described in this book are intended to be used for standard applications or general electronic equipment (such as office equipment, communications equipment, measuring instruments and household appliances).
Consult our sales staff in advance for information on the following applications:
 - Special applications (such as for airplanes, aerospace, automobiles, traffic control equipment, combustion equipment, life support systems and safety devices) in which exceptional quality and reliability are required, or if the failure or malfunction of the products may directly jeopardize life or harm the human body.
 - Any applications other than the standard applications intended.
- (4) The products and product specifications described in this book are subject to change without notice for modification and/or improvement. At the final stage of your design, purchasing, or use of the products, therefore, ask for the most up-to-date Product Standards in advance to make sure that the latest specifications satisfy your requirements.
- (5) When designing your equipment, comply with the range of absolute maximum rating and the guaranteed operating conditions (operating power supply voltage and operating environment etc.). Especially, please be careful not to exceed the range of absolute maximum rating on the transient state, such as power-on, power-off and mode-switching. Otherwise, we will not be liable for any defect which may arise later in your equipment.
 - Even when the products are used within the guaranteed values, take into the consideration of incidence of break down and failure mode, possible to occur to semiconductor products. Measures on the systems such as redundant design, arresting the spread of fire or preventing glitch are recommended in order to prevent physical injury, fire, social damages, for example, by using the products.
- (6) Comply with the instructions for use in order to prevent breakdown and characteristics change due to external factors (ESD, EOS, thermal stress and mechanical stress) at the time of handling, mounting or at customer's process. When using products for which damp-proof packing is required, satisfy the conditions, such as shelf life and the elapsed time since first opening the packages.
- (7) This book may be not reprinted or reproduced whether wholly or partially, without the prior written permission of our company.