

1 General Description

The AS5304/AS5306 are single-chip IC's with integrated Hall elements for measuring linear or rotary motion using multi-pole magnetic strips or rings.

This allows the usage of the AS5304/AS5306 in applications where the Sensor IC cannot be mounted at the end of a rotating device (e.g. at hollow shafts). Instead, the AS5304/AS5306 are mounted off-axis underneath a multi-pole magnetized ring or strip and provides a quadrature incremental output with 40 pulses per pole period at speeds of up to 20 meters/sec (AS5304) or 12 meters/sec (AS5306).

A single index pulse is generated once for every pole pair at the Index output.

Using, for example, a 32pole-pair magnetic ring, the AS5304/AS5306 can provide a resolution of 1280 pulses/rev, which is equivalent to 5120 positions/rev or 12.3bit. The maximum speed at this configuration is 9375 rpm.

The pole pair length is 4mm (2mm north pole / 2mm south pole) for the AS5304, and 2.4mm (1.2mm north pole / 1.2mm south pole) for the AS5306. The chip accepts a magnetic field strength down to 5mT (peak).

Both chips are available with push-pull outputs (AS530xA) or with open drain outputs (AS530xB).

The AS5304/AS5306 are available in a small 20-pin TSSOP package and specified for an operating ambient temperature of -40° to +125°C.

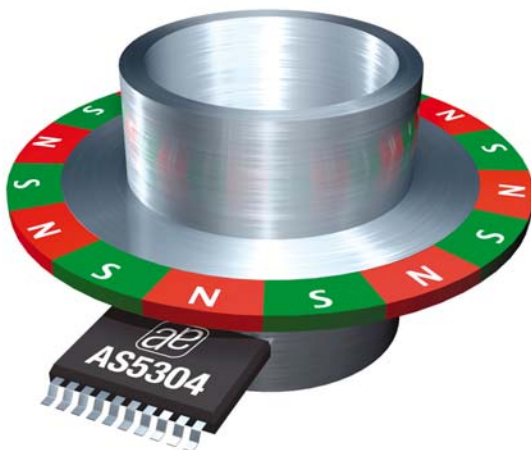

Figure 1: AS5304 (AS5306) with multi-pole ring magnet.

2 Benefits

- Complete system-on-chip
- High reliability due to non-contact sensing
- Suitable for the use in harsh environments
- Robust against external magnetic stray fields

3 Key Features

- High speed, up to 20m/s (AS5304)
12m/s (AS5306)
- Magnetic pole pair length: 4mm (AS5304) or 2.4mm (AS5306)
- Resolution: 25µm (AS5304) or 15µm (AS5306)
- 40 pulses / 160 positions per magnetic period.
- 1 index pulse per pole pair
- Linear movement measurement using multi-pole magnetic strips
- Circular off-axis movement measurement using multi-pole magnetic rings
- 4.5 to 5.5V operating voltage
- Magnetic field strength indicator, magnetic field alarm for end-of-strip or missing magnet

4 Applications

The AS5304/AS5306 are ideal for high speed linear motion and off-axis rotation measurement in applications such as

- electrical motors
- X-Y-stages
- rotation knobs
- industrial drives

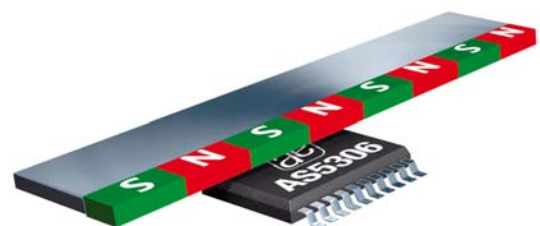

Figure 2: AS5306 (AS5304) with magnetic multi-pole strip magnet for linear motion measurement

5 Functional Description

The AS5304/AS5306 require a multi-pole magnetic strip or ring with a pole length of 2mm (4mm pole pair length) on the AS5304, and a pole length of 1.2mm (2.4mm pole pair length) on the AS5306. The magnetic field strength of the multi-pole magnet should be in the range of 5 to 60mT at the chip surface.

The Hall elements on the AS5304/AS5306 are arranged in a linear array.

By moving the multi-pole magnet over the Hall array, a sinusoidal signal (SIN) is generated internally. With proper configuration of the Hall elements, a second 90° phase shifted sinusoidal signal (COS) is obtained. Using an interpolation circuit, the length of a pole pair is divided into 160 positions and further decoded into 40 quadrature pulses.

An Automatic Gain Control provides a large dynamic input range of the magnetic field.

An Analog output pin (AO) provides an analog voltage that changes with the strength of the magnetic field (see chapter 8).

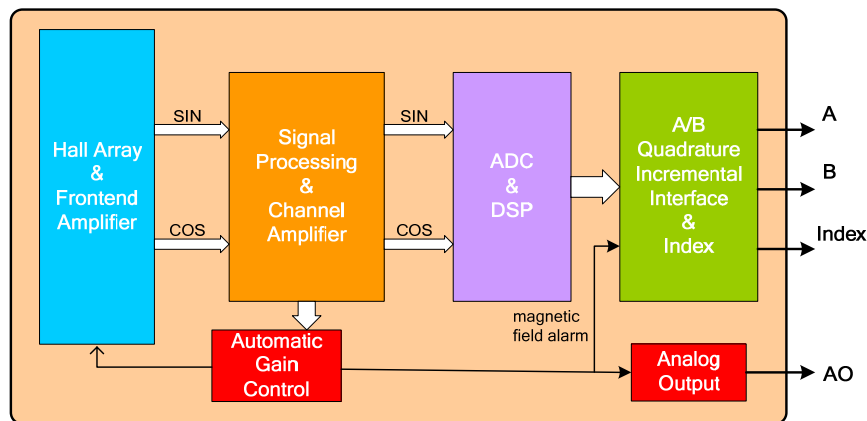

Figure 3: AS5304 / AS5306 block diagram

6 Sensor Placement in Package

TSSOP20 / 0.65mm pin pitch

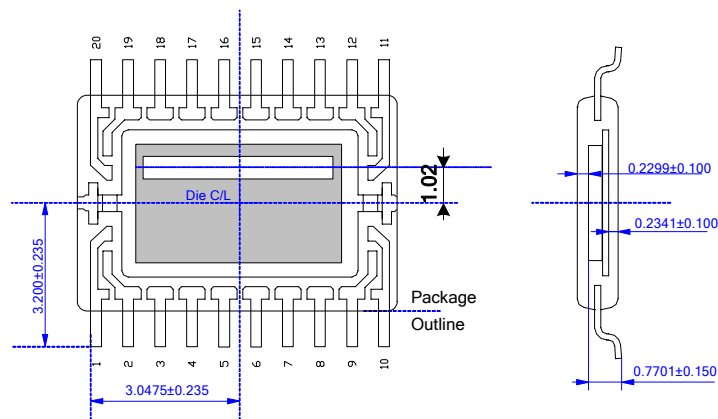

Figure 4: Sensor in package

Die Tilt Tolerance $\pm 1^\circ$

Dimensions						
Symbol	mm			inch		
	Min	Typ	Max	Min	Typ	Max
A	-	-	1.20	-	-	0.047
A1	0.05	-	0.15	0.002	-	0.006
A2	0.80	1.00	1.05	0.031	0.039	0.041
b	0.19	-	0.30	0.007	-	0.012
c	0.09	-	0.20	0.004	-	0.008
D	6.40	6.50	6.60	0.252	0.256	0.260
E	6.40			0.252		
E1	4.30	4.40	4.50	0.169	0.173	0.177
e	0.65			0.0256		
K	0°	-	8°	0°	-	8°
L	0.45	0.60	0.75	0.018	0.024	0.030

Marking: AYWWIZZ

A: Pb-Free Identifier
 Y: Last Digit of Manufacturing Year
 WW: Manufacturing Week
 I: Plant Identifier
 ZZ: Traceability Code

JEDEC Package Outline Standard:
 MO-153-AC

Thermal Resistance $R_{th(j-a)}$:
 89 K/W in still air, soldered on PCB.

IC's marked with a white dot or the letters "ES" denote Engineering Samples

6.3 Electrical Connection

The supply pins VDD, VDDP and VDDA are connected to +5V. Pins VSS and TEST_GND are connected to the supply ground. A 100nF decoupling capacitor close to the device is recommended.

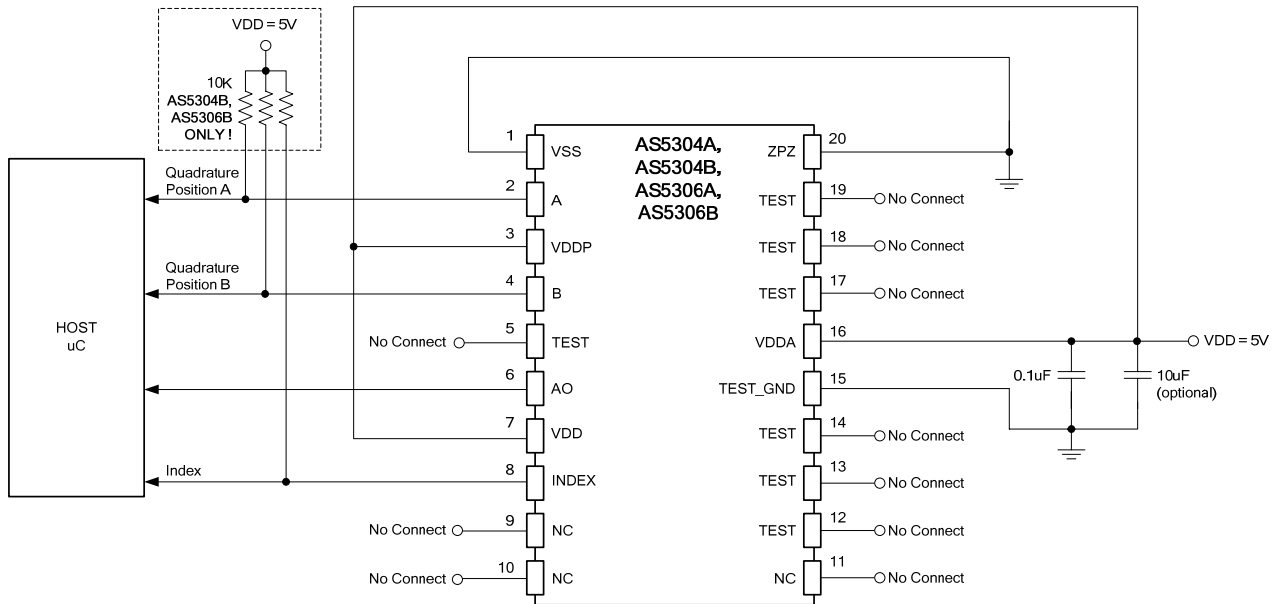

Figure 5: Electrical connection of the AS5304/AS5306

7 Incremental Quadrature AB Output

The digital output is compatible to optical incremental encoder outputs. Direction of rotation is encoded into two signals A and B that are phase-shifted by 90°. Depending on the direction of rotation, A leads B (CW) or B leads A (CCW).

7.1.1 Index Pulse

A single index pulse is generated once for every pole pair. One pole pair is interpolated to 40 quadrature pulses (160 steps), so one index pulse is generated after every 40 quadrature pulses (see Figure 6)

The Index output is switched to Index = high, when a magnet is placed over the Hall array as shown in Figure 7, top graph: the north pole of the magnet is placed over the left side of the IC (top view, pin#1 at bottom left) and the south pole is placed over the right side of the IC.

The index output will switch back to Index = low, when the magnet is moved by one LSB from position X=0 to X=X1, as shown in Figure 7, bottom graph. One LSB is 25µm for AS5304 and 15µm for AS5306.

Note: Since the small step size of 1 LSB is hardly recognizable in a correctly scaled graph it is shown as an exaggerated step in the bottom graph of Figure 7.

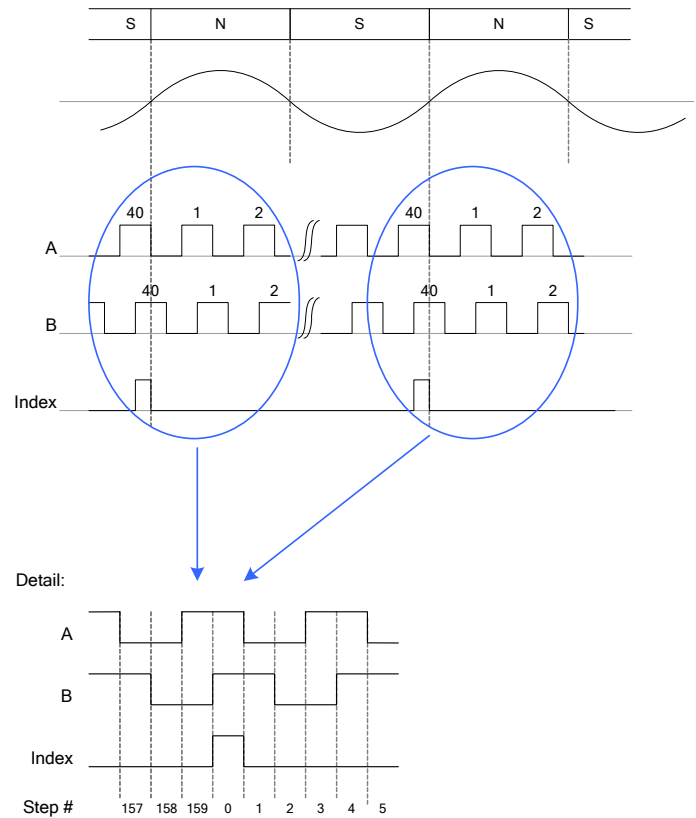

Figure 6: Quadrature A / B and Index output

7.1.2 Magnetic Field Warning Indicator

The AS5304 can also provide a low magnetic field warning to indicate a missing magnet or when the end of the magnetic strip has been reached. This condition is indicated by using a combination of A, B and Index, that does not occur in normal operation:

A low magnetic field is indicated with:

Index = high

A=B=low

7.1.3 Vertical Distance between Magnet and IC

The recommended vertical distance between magnet and IC depends on the strength of the magnet and the length of the magnetic pole.

Typically, the vertical distance between magnet and chip surface should not exceed ½ of the pole length.

That means for AS5304, having a pole length of 2.0mm, the maximum vertical gap should be 1.0mm,

For the AS5306, having a pole length of 1.2mm, the maximum vertical gap should be 0.6mm

These figures refer to the chip surface. Given a typical distance of 0.2mm between chip surface and IC package surface, the recommended vertical distances between magnet and IC surface are therefore:

AS 5304: ≤ 0.8mm

AS 5306: ≤ 0.4mm

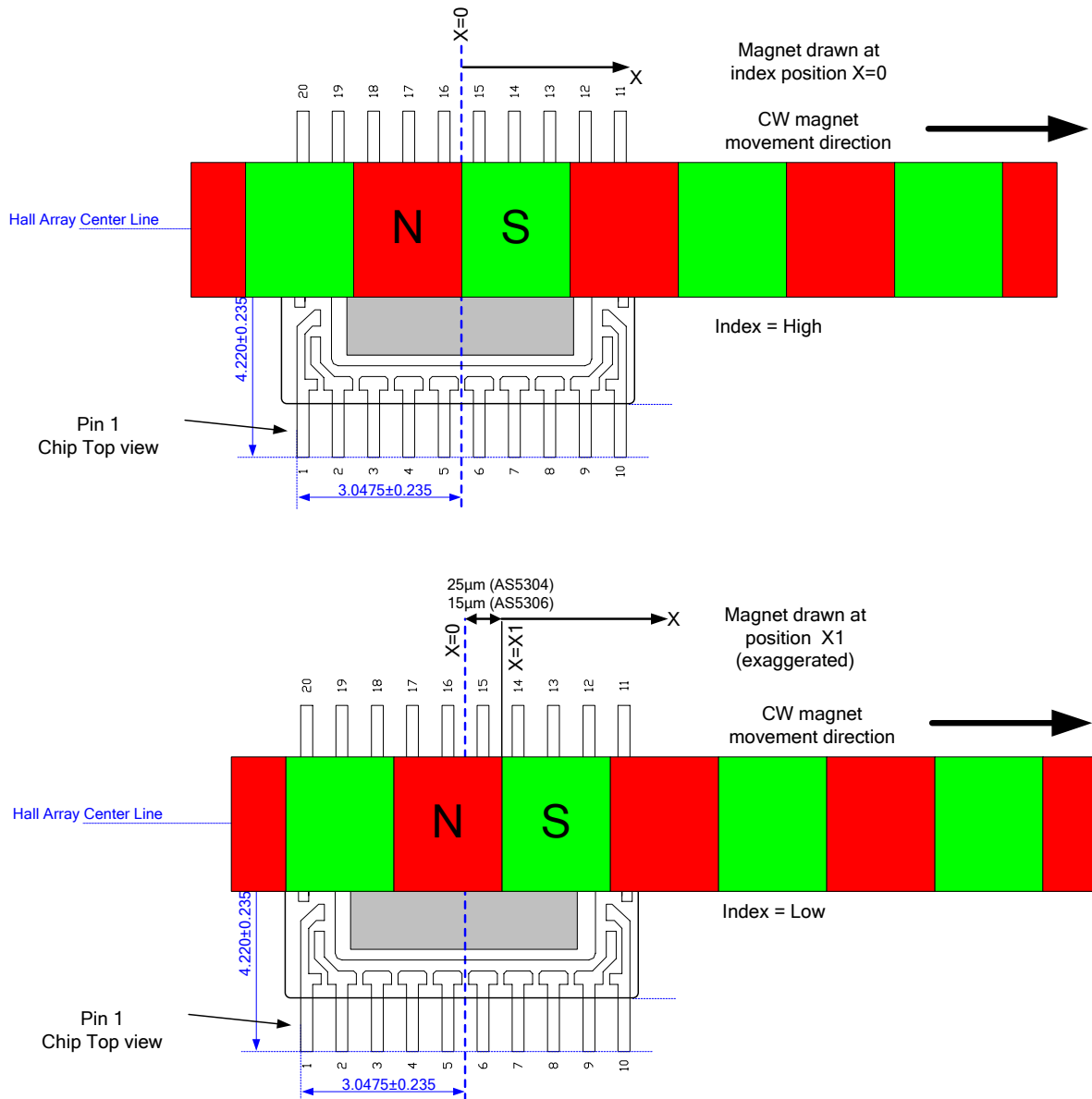

Figure 7: Magnet placement for index pulse generation

7.1.4 Soft Stop Feature for Linear Movement Measurement

When using long multi-pole strips, it may often be necessary to start from a defined home (or zero) position and obtain absolute position information by counting the steps from the defined home position. The AS5304/AS5306 provide a soft stop feature that eliminates the need for a separate electro-mechanical home position switch or an optical light barrier switch to indicate the home position.

The magnetic field warning indicator (see 7.1.2) together with the index pulse can be used to indicate a unique home position on a magnetic strip:

1. First the AS5304/AS5306 move to the end of the strip, until a magnetic field warning is displayed (Index = high, A=B=low)
2. Then, the AS5304/AS5306 move back towards the strip until the first index position is reached (note: an index position is generated once for every pole pair, it is indicated with: Index = high, A=B= high). Depending on the polarity of the strip magnet, the first index position may be generated when the end of the magnet strip only covers one half of the Hall array. This position is not recommended as a defined home position, as the accuracy of the AS5304/AS5306 are reduced as long as the multi-pole strip does not fully cover the Hall array.

- It is therefore recommended to continue to the next (second) index position from the end of the strip (Index = high, A=B= high). This position can now be used as a defined home position.

7.2 Incremental Hysteresis

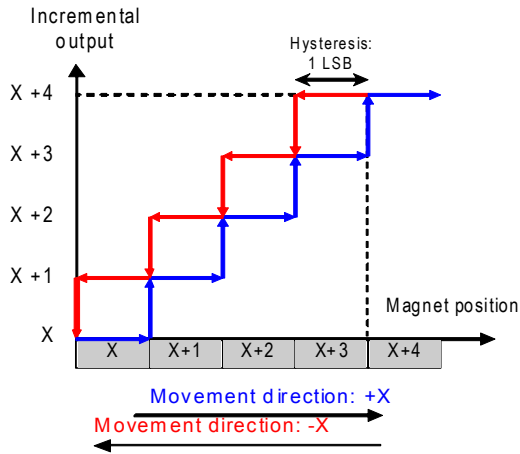

Figure 8: Hysteresis of the incremental output

If the magnet is sitting right at the transition point between two steps, the noise in the system may cause the incremental outputs to jitter back and forth between these two steps, especially when the magnetic field is weak.

To avoid this unwanted jitter, a hysteresis has been implemented. The hysteresis lies between 1 and 2 LSB, depending on device scattering. Figure 8 shows an example of 1LSB hysteresis: the horizontal axis is the lateral position of the magnet as it scans across the IC, the vertical axis is the change of the incremental outputs, as they step forward (blue line) with movement in +X direction and backward (red line) in -X direction.

Note: 1LSB = 25µm for AS5304, 15µm for AS5306

7.3 Integral Non-Linearity (INL)

The INL (integral non-linearity) is the deviation between indicated position and actual position. It is better than 1LSB for both AS5304 and AS5306, assuming an ideal magnet. Pole length variations and imperfections of the magnet material, which lead to a non-sinusoidal magnetic field will attribute to additional linearity errors.

7.3.1 Error Caused by Pole Length Variations

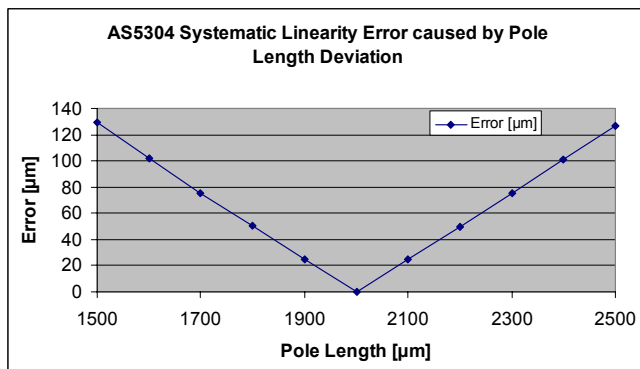

Figure 9: Additional error caused by pole length variation: AS5304

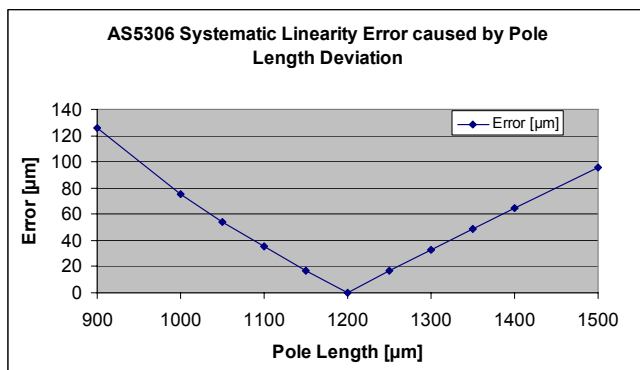

Figure 10: Additional error caused by pole length variation: AS5306

Figure 9 and Figure 10 show the error caused by a non-ideal pole length of the multi-pole strip or ring.

This is less of an issue with strip magnets, as they can be manufactured exactly to specification using the proper magnetization tooling.

However, when using a ring magnet (see Figure 1) the pole length differs depending on the measurement radius. For optimum performance it is therefore essential to mount the IC such that the Hall sensors are exactly underneath the magnet at the radius where the pole length is 2.0mm (AS5304) or 1.2mm (AS5306), see also 8.1.2.

Note that this is an additional error, which must be added to the intrinsic errors INL (see 7.3) and DNL (see 7.4).

7.4 Dynamic Non-Linearity (DNL)

The DNL (dynamic non-linearity) describes the non-linearity of the incremental outputs from one step to the next. In an ideal system, every change of the incremental outputs would occur after exactly one LSB (e.g. 25µm on AS5304). In practice however, this step size is not ideal, the output state will change after 1LSB +/-DNL. The DNL must be <+/- ½ LSB to avoid a missing code. Consequently, the incremental outputs will change when the magnet movement over the IC is minimum 0.5 LSB and maximum 1.5 LSB's.

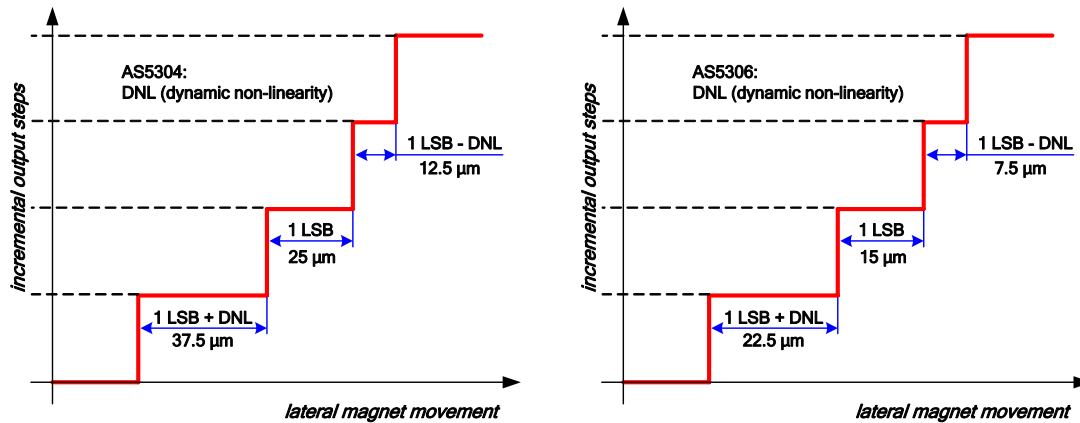

Figure 11: DNL of AS5304 (left) and AS5306 (right)

8 The AO Output

The Analog Output (AO) provides an analog output voltage that represents the Automatic Gain Control (AGC) of the Hall sensors signal control loop.

This voltage can be used to monitor the magnetic field strength and hence the gap between magnet and chip surface:

- Short distance between magnet and IC → strong magnetic field → low loop gain → low AO voltage
- Long distance between magnet and IC → weak magnetic field → high loop gain → high AO voltage

For ideal operation, the AO voltage should be between 1.0 and 4.0V (typical; see 9.5).

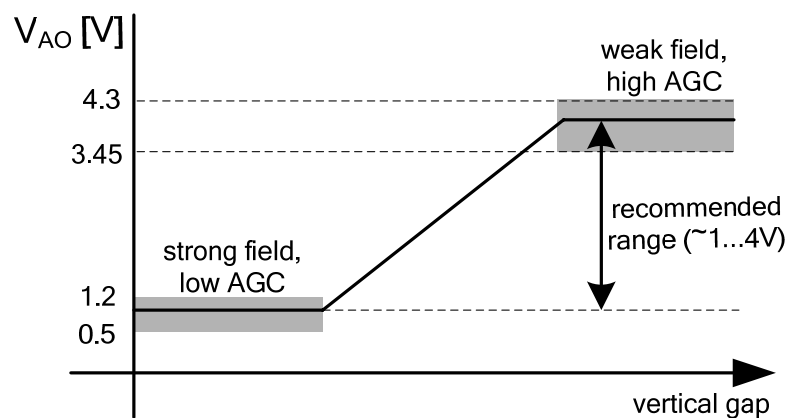

Figure 12: AO output versus AGC, magnetic field strength, magnet-to-IC gap

8.1 Resolution and Maximum Rotating Speed

When using the AS5304/AS5306 in an off-axis rotary application, a multi-pole ring magnet must be used. Resolution, diameter and maximum speed depend on the number of pole pairs on the ring.

8.1.1 Resolution

The angular resolution increases linearly with the number of pole pairs. One pole pair has a resolution (= interpolation factor) of 160 steps or 40 quadrature pulses.

Resolution [steps] = **[interpolation factor] x [number of pole pairs]**

Resolution [bit] = **log (resolution[steps]) / log (2)**

Example: multi-pole ring with 22 pole pairs

Resolution = 160x22 = 3520 steps per revolution
 = 40x22 = 880 quadrature pulses / revolution
 = 11.78 bits per revolution = 0.1023° per step

8.1.2 Multi-pole Ring Diameter

The length of a pole pair across the median of the multi-pole ring must remain fixed at either 4mm (AS5304) or 2.4mm (AS5306). Hence, with increasing pole pair count, the diameter increases linearly with the number of pole pairs on the magnetic ring.

Magnetic ring diameter = **[pole length] * [number of pole pairs] / π**

for AS5304: d = 4.0mm * number of pole pairs / π

for AS5306: d = 2.4mm * number of pole pairs / π

Example: same as above: multi-pole ring with 22 pole pairs for AS5304

Ring diameter = 4 * 22 / 3.14 = 28.01mm (this number represents the median diameter of the ring, this is where the Hall elements of the AS5304/AS5306 should be placed; see Figure 4)

For the AS5306, the same ring would have a diameter of: 2.4 * 22 / 3.14 = 16.8mm

8.1.3 Maximum Rotation Speed

The AS5304/AS5306 use a fast interpolation technique allowing an input frequency of 5kHz. This means, it can process magnetic field changes in the order of 5000 pole pairs per second or 300,000 revolutions per minute. However, since a magnetic ring consists of more than one pole pair, the above figure must be divided by the number of pole pairs to get the maximum rotation speed:

Maximum rotation speed = **300,000 rpm / [number of pole pairs]**

Example: same as above: multi-pole ring with 22 pole pairs:

Max. speed = 300,000 / 22 = 13,636 rpm (this is independent of the pole length)

8.1.4 Maximum Linear Travelling Speed

For linear motion sensing, a multi-pole strip using equally spaced north and south poles is used. The pole length is again fixed at 2.0mm for the AS5304 and 1.2mm for the AS5306. As shown in 8.1.3 above, the sensors can process up to 5000 pole pairs per second, so the maximum travelling speed is:

Maximum linear travelling speed = **5000 * [pole pair length]**

Example: linear multi-pole strip:

Max. linear travelling speed = 4mm * 5000 1/sec = 20,000mm/sec = 20m/sec for AS5304

Max. linear travelling speed = 2.4mm * 5000 1/sec = 12,000mm/sec = 12m/sec for AS5306

9 GENERAL DEVICE SPECIFICATIONS

9.1 Absolute Maximum Ratings (Non Operating)

Stresses beyond those listed under "Absolute Maximum Ratings" may cause permanent damage to the device.

Parameter	Symbol	Min	Max	Unit	Note
Supply	VDD	-0.3	7	V	
Input pin voltage	V _{in}	VSS-0.5	VDD+0.5	V	
Input current (latchup immunity)	I _{scr}	-100	100	mA	Norm: Jedec 18
ESD		+/-2		kV	Norm: MIL 883 E method 3015
Package thermal resistance	θ _{JA}		114.5	°C /W	Still Air / Single Layer PCB
Storage temperature	T _{strg}	-55	150	°C	
Soldering conditions	T _{body}		260	°C	Norm: IPC/JEDEC J-STD-020C
Humidity non-condensing		5	85	%	

9.2 Operating Conditions

Parameter	Symbol	Min	Typ	Max	Unit	Note
Positive supply voltage	AVDD	4.5	5.0	5.5	V	
Digital supply voltage	DVDD					
Negative supply voltage	VSS	0.0	0.0	0.0	V	
Power supply current, AS5304	IDD	25		35	mA	A/B/Index, AO unloaded!
Power supply current, AS5306		20		30		
Ambient temperature	T _{amb}	-40		125	°C	
Junction temperature	T _J	-40		150	°C	
Resolution	LSB		25		µm	AS5304
			15			AS5306
Integral nonlinearity	INL			1	LSB	Ideal input signal (ErrMax - ErrMin) / 2
Differential nonlinearity	DNL			±0.5	LSB	No missing pulses. optimum alignment
Hysteresis	Hyst	1	1.5	2	LSB	

9.3 System Parameters

Parameter	Symbol	Min	Max	Unit	Note
Power up time	T _{PwrUp}		500	µs	Amplitude within valid range / Interpolator locked, A B Index enabled
Propagation delay	T _{Prop}		20	µs	Time between change of input signal to output signal

9.4 A / B / C Push/Pull or Open Drain Output

Push Pull Mode is set for AS530xA, Open Drain Mode is set for AS530xB versions.

Parameter	Symbol	Min	Typ	Max	Unit	Note
High level output voltage	V_{OH}	0.8 VDD			V	Push/Pull mode
Low level output voltage	V_{OL}			0.4 + VSS	V	
Current source capability	I_{LOH}	12	14		mA	Push/Pull mode
Current sink capability	I_{LOL}	13	15		mA	
Short circuit limitation current	I_{Short}		25	39	mA	Reduces maximum operating temperature
Capacitive load	C_L		20		pF	See Figure 13
Load resistance	R_L		820		Ω	See Figure 13
Rise time	t_R			1.2	μs	Push/Pull mode
Fall time	t_F			1.2	μs	

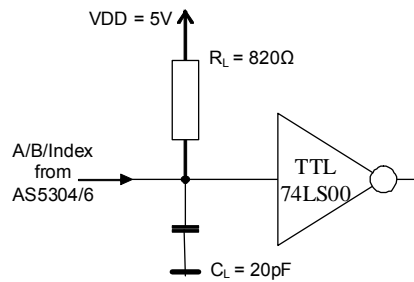

Figure 13: Typical digital load

9.5 CAO Analogue Output Buffer

Parameter	Symbol	Min	Typ	Max	Unit	Note
Minimum output voltage	$V_{OutRange}$	0.5	1	1.2	V	Strong field, min. AGC
Maximum output voltage	$V_{OutRange}$	3.45	4	4.3	V	Weak field, max. AGC
Offset	V_{Offs}			± 10	mV	
Current sink / source capability	I_L	5			mA	
Average short circuit current	I_{Short}	6		40	mA	Reduces maximum Operating Temperature
Capacitive load	C_L		10		pF	
Bandwidth	BW		5		KHz	

9.6 Magnetic Input

Parameter	Symbol	Min	Typ	Max	Unit	Note
Magnetic pole length	L _{P_FP}		2.0		mm	AS5304
			1.2			AS5306
Magnetic pole pair length	T _{FP}		4.0		mm	AS5304
			2.4			AS5306
Magnetic amplitude	A _{mag}	5		60	mT	
Operating dynamic input range		1:12		1:24		
Magnetic offset	Off _{mag}			±0.5	mT	
Magnetic temperature drift	T _{dmag}			-0.2	%/K	
Input frequency	f _{mag}	0		5	kHz	

Table 1: AS5304 ordering guide

Device	Resolution	Magnet Pole Length	Digital Outputs
AS5304A	25µm	2mm	Push Pull
AS5304B	25µm	2mm	Open Drain

Table 2: AS5306 ordering guide

Device	Resolution	Magnet Pole Length	Digital Outputs
AS5306A	15µm	1.2mm	Push Pull
AS5306B	15µm	1.2mm	Open Drain

Contact

Headquarters

austriamicrosystems AG

A 8141 Schloss Premstätten, Austria

Phone: +43 3136 500 0

Fax: +43 3136 525 01

www.austriamicrosystems.com

Copyright

Devices sold by austriamicrosystems are covered by the warranty and patent indemnification provisions appearing in its Term of Sale. austriamicrosystems makes no warranty, express, statutory, implied, or by description regarding the information set forth herein or regarding the freedom of the described devices from patent infringement. austriamicrosystems reserves the right to change specifications and prices at any time and without notice. Therefore, prior to designing this product into a system, it is necessary to check with austriamicrosystems for current information. This product is intended for use in normal commercial applications.

Copyright © 2008 austriamicrosystems. Trademarks registered ®. All rights reserved. The material herein may not be reproduced, adapted, merged, translated, stored, or used without the prior written consent of the copyright owner. To the best of its knowledge, austriamicrosystems asserts that the information contained in this publication is accurate and correct. However, austriamicrosystems shall not be liable to recipient or any third party for any damages, including but not limited to personal injury, property damage, loss of profits, loss of use, interruption of business or indirect, special, incidental or consequential damages, of any kind, in connection with or arising out of the furnishing, performance or use of the technical data herein. No obligation or liability to recipient or any third party shall arise or flow out of austriamicrosystems rendering of technical or other services.