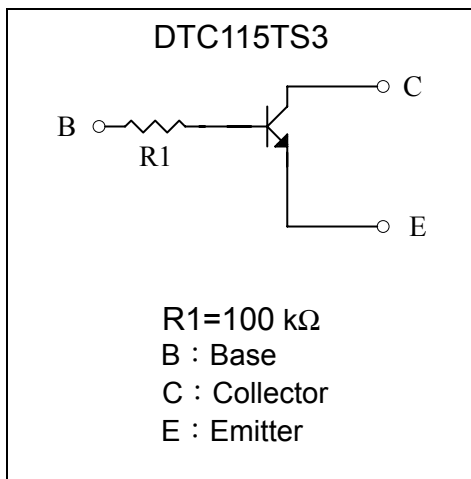
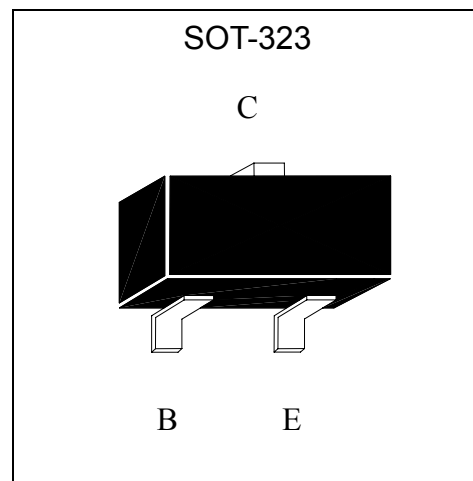

NPN Digital Transistors (Built-in Resistors)

DTC115TS3

Features

- Built-in bias resistors enable the configuration of an inverter circuit without connecting external input resistors (see equivalent circuit).
- The bias resistors consist of thin-film resistors with complete isolation to allow negative biasing of the input. They also have the advantage of almost completely eliminating parasitic effects.
- Only the on/off conditions need to be set for operation, making device design easy.
- Complements the DTA115TS3.
- Pb-free & Halogen-free package.

Equivalent Circuit

Outline

Absolute Maximum Ratings (Ta=25°C)

Parameter	Symbol	Limits	Unit
Collector-Base Voltage	V _{CBO}	50	V
Collector-Emitter Voltage	V _{CEO}	50	V
Emitter-Base Voltage	V _{EBO}	5	V
Collector Current	I _C	100	mA
Power Dissipation	P _d	200	mW
Junction Temperature	T _j	150	°C
Storage Temperature	T _{stg}	-55~+150	°C

**Electrical Characteristics** (Ta=25°C)

Parameter	Symbol	Min.	Typ.	Max.	Unit	Test Conditions
Collector-Base Breakdown Voltage	V _{CB0}	50	-	-	V	I _C =50μA
Collector-Emitter Breakdown Voltage	V _{CEO}	50	-	-	V	I _C =1mA
Emitter-Base Breakdown Voltage	V _{EB0}	5	-	-	V	I _E =50μA
Collector-Base Cutoff Current	I _{CB0}	-	-	0.5	μA	V _{CB} =50V
Emitter-Base Cutoff Current	I _{EB0}	-	-	0.5	μA	V _{EB} =4V
Collector-Emitter Saturation Voltage	V _{CE(sat)}	-	-	0.3	V	I _C =1mA, I _B =0.1mA
DC Current Gain	h _{FE}	100	-	600	-	V _{CE} =5V, I _C =1mA
Input Resistance	R	70	100	130	kΩ	-
Transition Frequency	f _T	-	250	-	MHz	V _{CE} =10V, I _C =5mA, f=100MHz *

* Transition frequency of the device

Ordering Information

Device	Package	Shipping	Marking
DTC115TS3	SOT-323 (Pb-free & Halogen-free package)	3000 pcs / Tape & Reel	8U

Characteristic Curves

Current Gain vs Collector Current

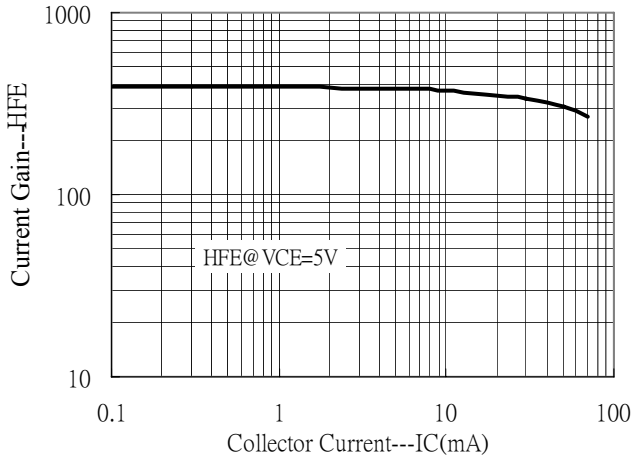

Saturation Voltage vs Collector Current

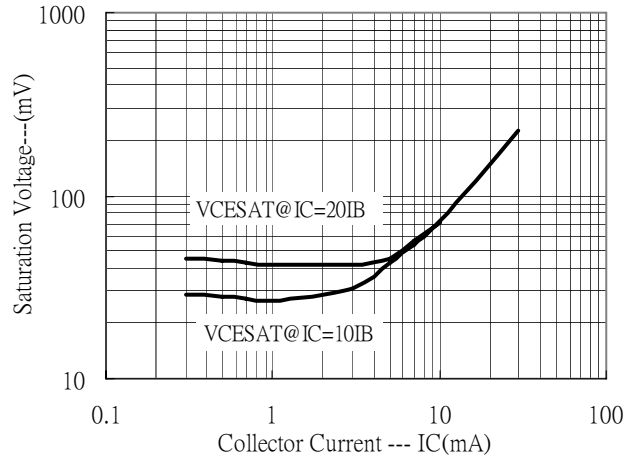

Power Derating Curve

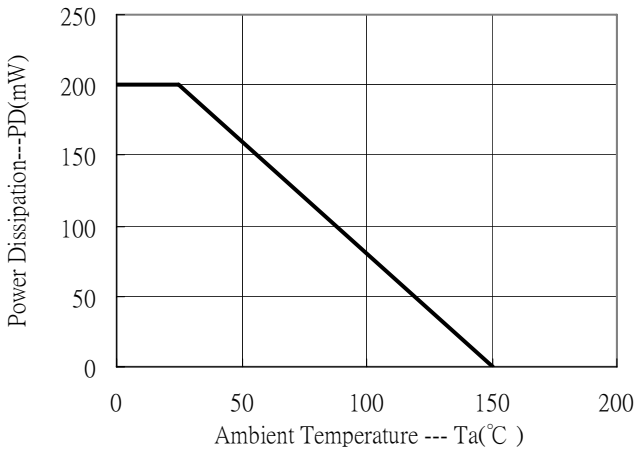

Reel Dimension

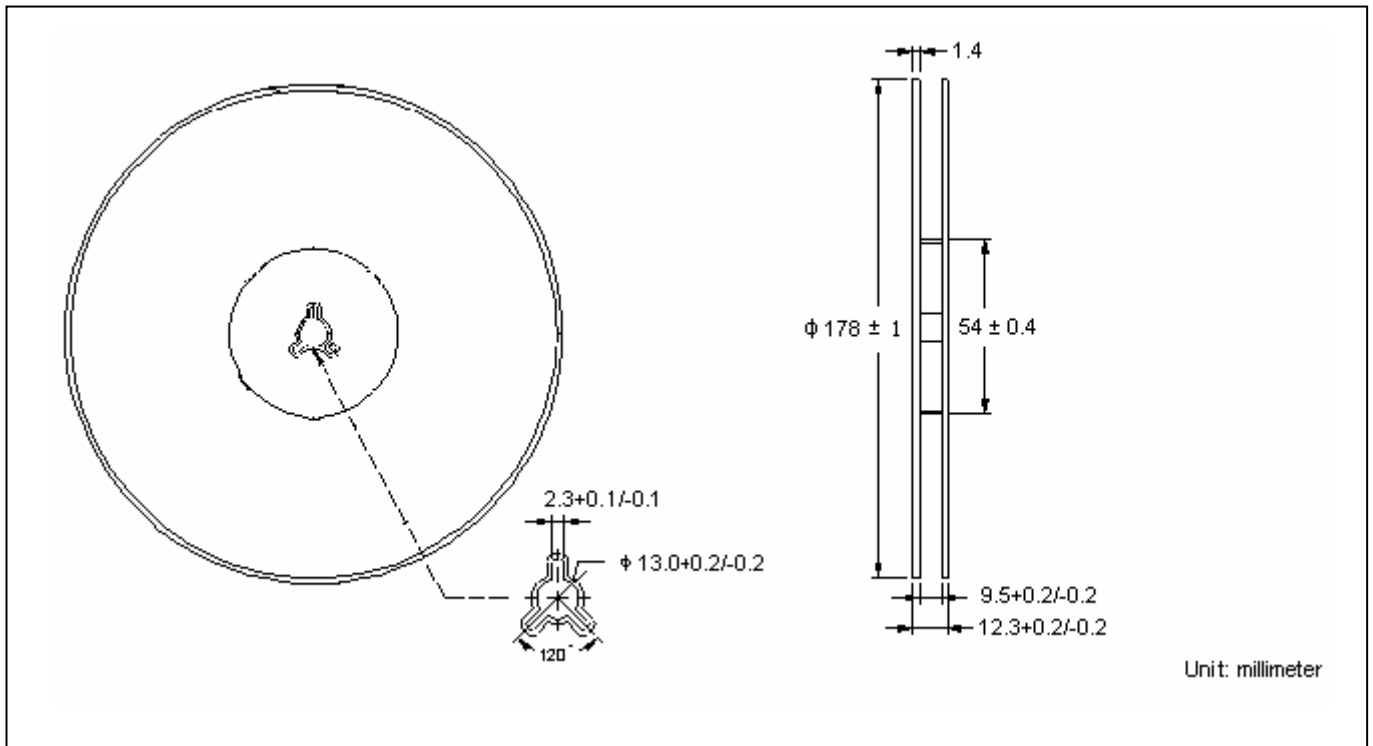

Carrier Tape Dimension

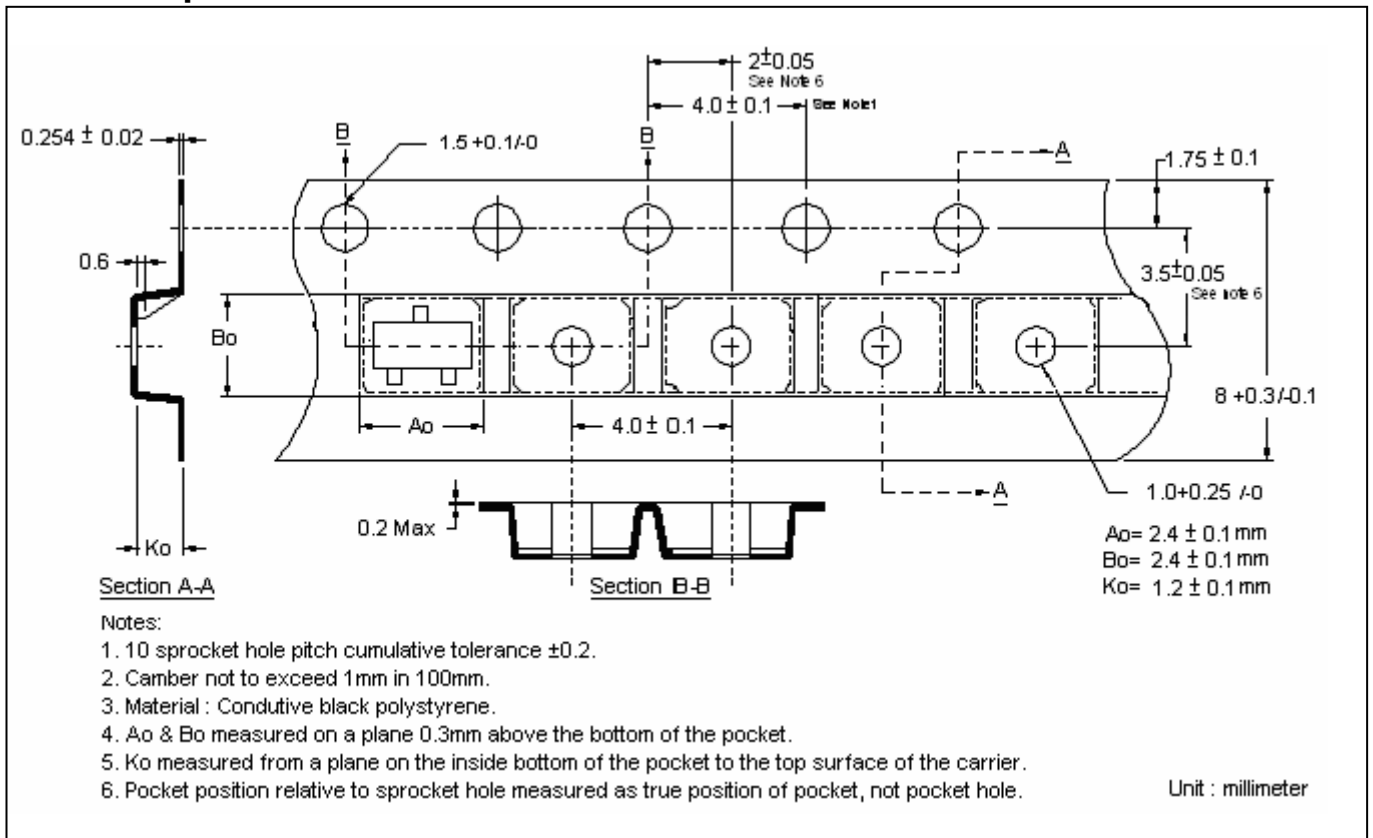

Recommended wave soldering condition

Product	Peak Temperature	Soldering Time
Pb-free devices	260 +0/-5 °C	5 +1/-1 seconds

Recommended temperature profile for IR reflow

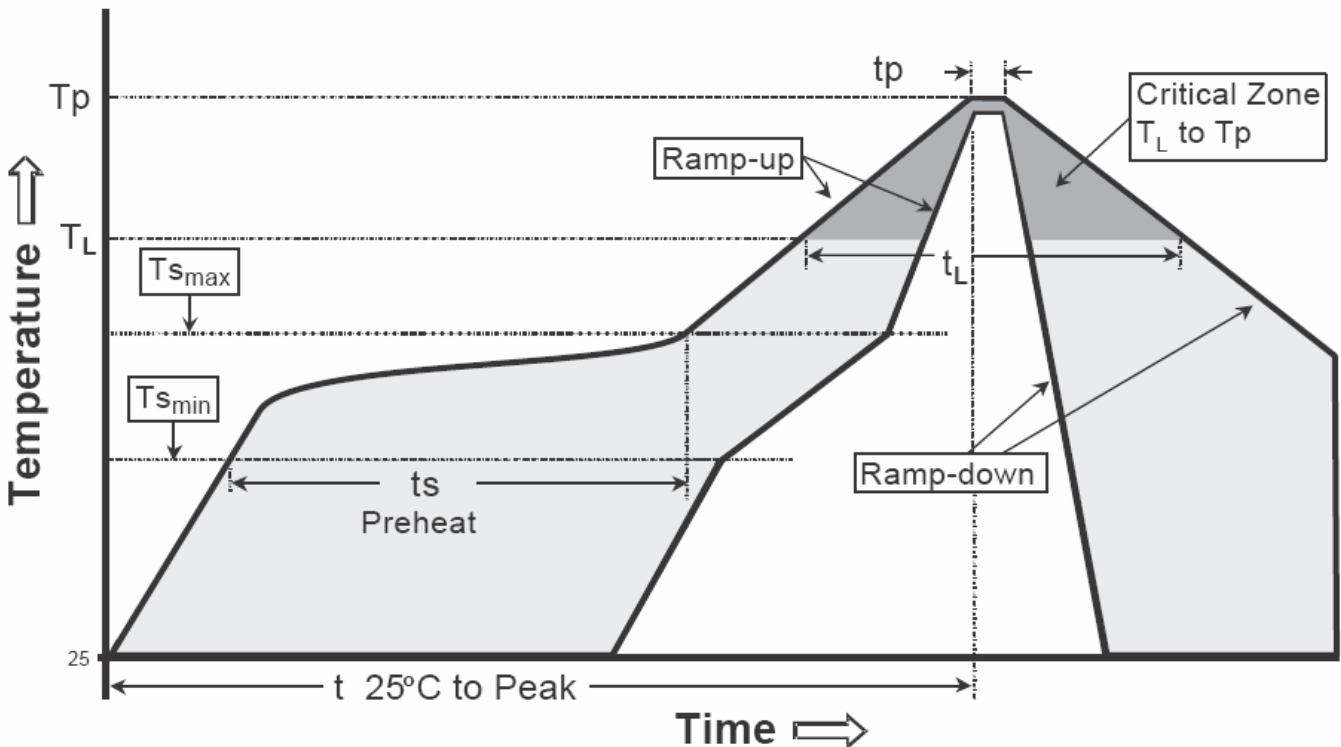

Profile feature	Sn-Pb eutectic Assembly	Pb-free Assembly
Average ramp-up rate (Tsmax to Tp)	3°C/second max.	3°C/second max.
Preheat		
-Temperature Min($T_{s_{min}}$)	100°C	150°C
-Temperature Max($T_{s_{max}}$)	150°C	200°C
-Time($t_{s_{min}}$ to $t_{s_{max}}$)	60-120 seconds	60-180 seconds
Time maintained above:		
-Temperature (T_L)	183°C	217°C
- Time (t_L)	60-150 seconds	60-150 seconds
Peak Temperature(T_p)	240 +0/-5 °C	260 +0/-5 °C
Time within 5°C of actual peak temperature(t_p)	10-30 seconds	20-40 seconds
Ramp down rate	6°C/second max.	6°C/second max.
Time 25 °C to peak temperature	6 minutes max.	8 minutes max.

Note : All temperatures refer to topside of the package, measured on the package body surface.

SOT-323 Dimension

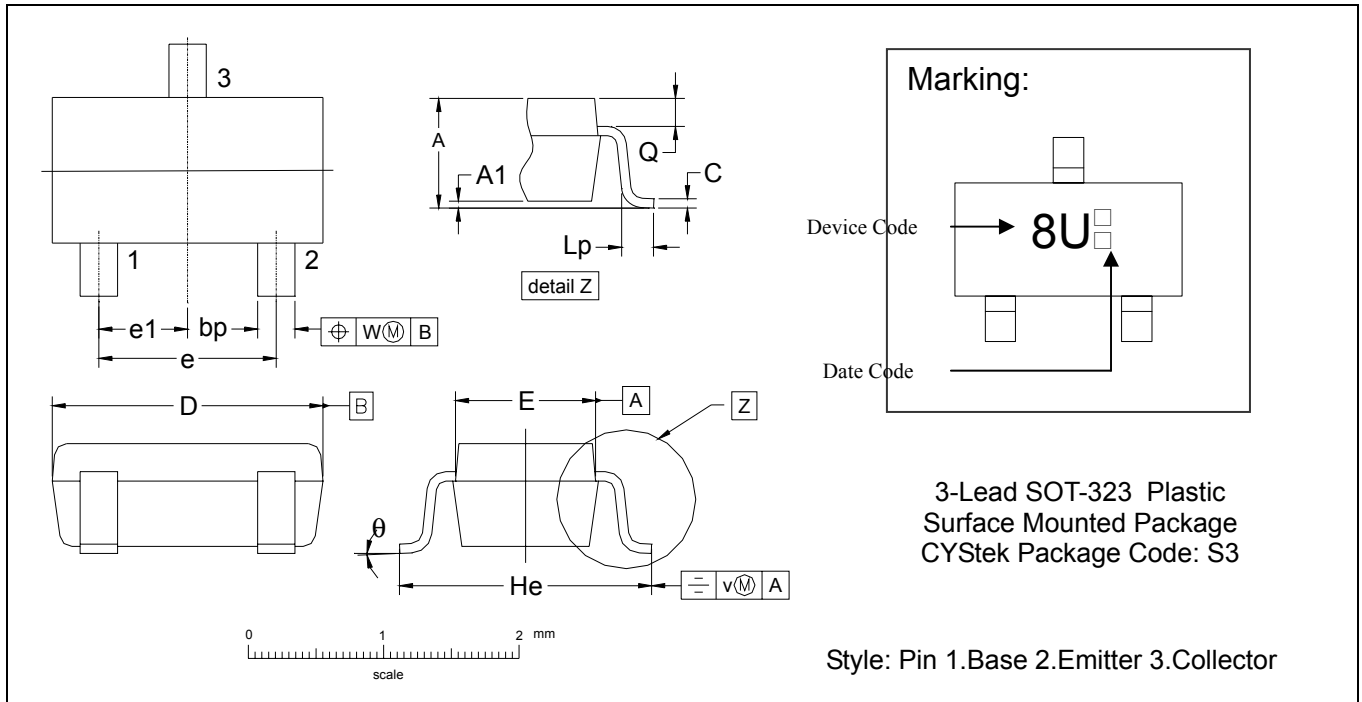

*: Typical

DIM	Inches		Millimeters		DIM	Inches		Millimeters	
	Min.	Max.	Min.	Max.		Min.	Max.	Min.	Max.
A	0.0315	0.0433	0.80	1.10	e1	0.0256*		0.65*	
A1	0.0000	0.0039	0.00	0.10	He	0.0787	0.0965	2.00	2.45
bp	0.0118	0.0157	0.30	0.40	Lp	0.0059	0.0181	0.15	0.46
C	0.0031	0.0098	0.08	0.25	Q	0.0051	0.0091	0.13	0.23
D	0.0709	0.0866	1.80	2.20	v	0.0079	-	0.2	-
E	0.0453	0.0531	1.15	1.35	w	0.0079	-	0.2	-
e	0.0472	0.0551	1.20	1.40	θ	0°	10°	0°	10°

Notes: 1.Controlling dimension: millimeters.
 2.Maximum lead thickness includes lead finish thickness, and minimum lead thickness is the minimum thickness of base material.
 3.If there is any question with packing specification or packing method, please contact your local CYStek sales office.

Material:

- Lead: Pure tin plated.
- Mold Compound: Epoxy resin family, flammability solid burning class: UL94V-0.

Important Notice:

- All rights are reserved. Reproduction in whole or in part is prohibited without the prior written approval of CYStek.
- CYStek reserves the right to make changes to its products without notice.
- CYStek **semiconductor products are not warranted to be suitable for use in Life-Support Applications, or systems.**
- CYStek assumes no liability for any consequence of customer product design, infringement of patents, or application assistance.