

### GENERAL DESCRIPTION

The PT1206 is a high efficiency 1.5MHz synchronous step-down DC-DC regulator IC capable of delivering up to 1A current. The PT1206 operates over a wide input voltage range from 2.5V to 6V; the main switch and the synchronous switch have been integrated with very low  $R_{DS(ON)}$  to minimize the conduction loss.

Low output voltage ripples with small external inductor and capacitor size are achieved with 1.5MHz switching frequency.

### FEATURES

- Low  $R_{DS(ON)}$  for internal switches (top/bottom) 250m $\Omega$ /200m $\Omega$
- 2.5V~6.0V input voltage range
- 1.5MHz switching frequency minimizes the external components
- Internal soft-start limits the inrush current
- 100% duty-cycle operation
- RoHS compliant

### APPLICATIONS

- Portable Navigation Device
- Smart phone
- USB Dongle
- Set Top Box
- Media Player

### ORDERING INFORMATION

PACKAGE	TEMPERATURE RANGE	ORDERING PART NUMBER	TRANSPORT MEDIA	MARKING
SOT23-5	-40°C to 85°C	PT1206E23F	Tape and Reel 3000 units	1206

### TYPICAL APPLICATION CIRCUIT

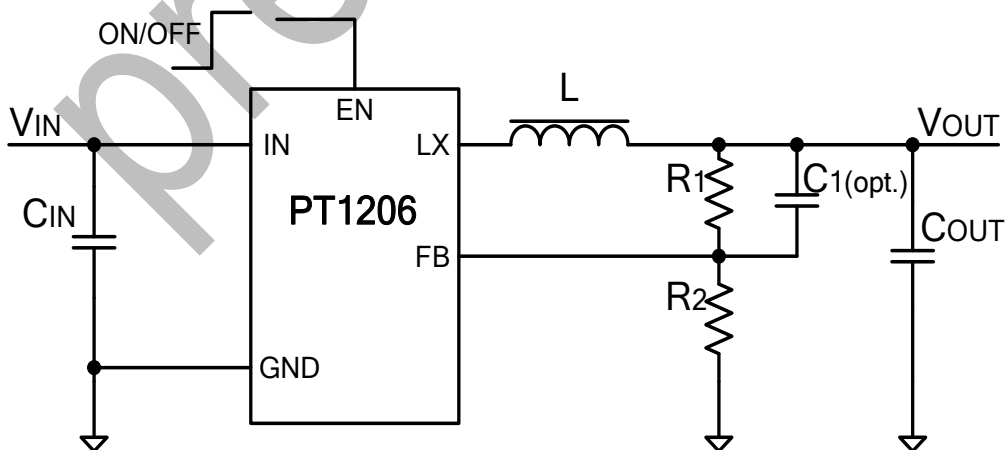

### PIN ASSIGNMENT

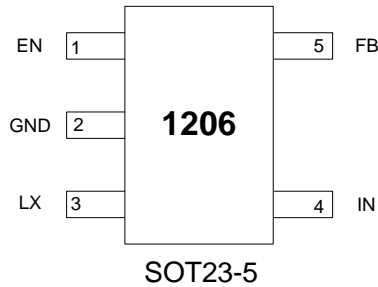

### PIN DESCRIPTIONS

PIN	SYMBOL	DESCRIPTION
1	EN	Enable control. Pull high to turn on. Do not float.
2	GND	Ground pin
3	LX	Inductor pin. Connect this pin to the switching node of inductor.
4	IN	Input pin. Decouple this pin to GND pin with at least 1 $\mu$ F ceramic cap.
5	FB	Output Feedback Pin. Connect this pin to the center point of the output resistor divider to program the output voltage: $V_{OUT}=0.6*(1+R1/R2)$ .

preliminary

### ABSOLUTE MAXIMUM RATINGS (Note1)

SYMBOL	PARAMETER	VALUE	UNIT
$V_{IN}$	Supply Input Voltage	8.0	V
$V_{EN}$	Enable Voltage	$V_{IN}$	V
$V_{FB}$	FB Voltage	8.0	V
$\theta_{JA}$	Package Thermal Resistance	250	$^{\circ}C/W$
$\theta_{JC}$	Package Thermal Resistance	130	$^{\circ}C/W$
$T_{LEAD}$	Lead Temperature	260	$^{\circ}C$
$T_{STG}$	Storage Temperature	-65~150	$^{\circ}C$
	ESD Susceptibility Human Body Mode	2000	V

Note1: Exceeding these ratings may cause damage to the device.

### RECOMMENDED OPERATING CONDITIONS (Note 2)

SYMBOL	PARAMETER	VALUE	UNIT
$V_{IN}$	Supply Input Voltage	2.5 ~ 6.0	V
$T_J$	Junction Temperature Range	-40 ~ 125	$^{\circ}C$
$T_A$	Ambient Temperature Range	-40 ~ 85	$^{\circ}C$

Note2: The device is not guaranteed to function outside of its operating rating.

### FUNCTIONAL BLOCK DIAGRAM

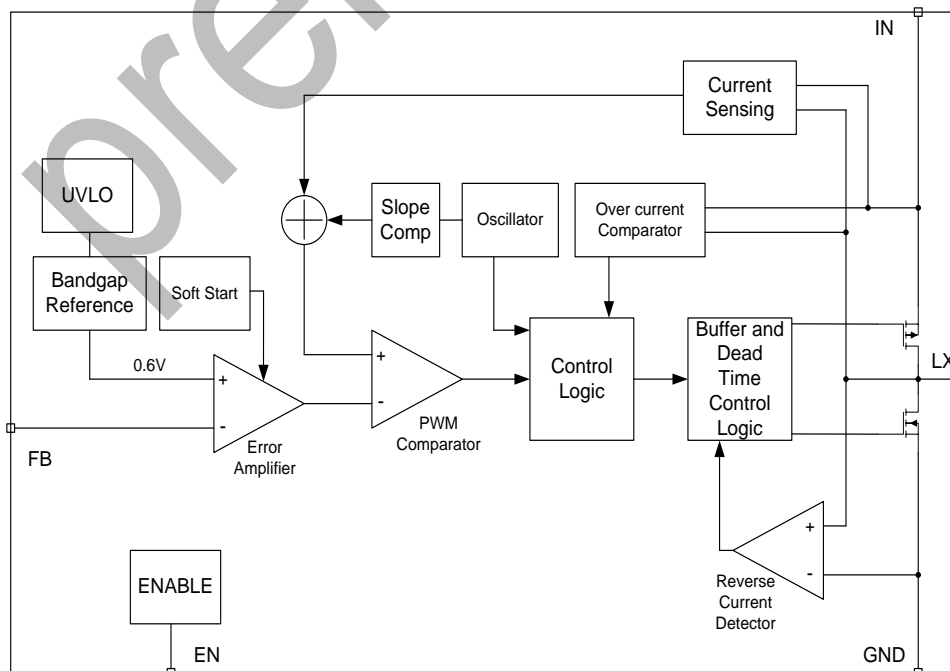

### ELECTRICAL CHARACTERISTICS

( $V_{IN}=5V$ ,  $V_{OUT}=2.5V$ ,  $L=2.2\mu H$ ,  $C_{OUT}=10\mu F$ ,  $T_A=25^\circ C$ , unless otherwise specified)

SYMBOL	PARAMETER	TEST CONDITION	MIN	TYP	MAX	UNIT
$V_{IN}$	Supply Input Voltage		2.5	-	6.0	V
$I_Q$	Quiescent Current	$I_{OUT} = 0 A$ , $V_{FB} = 0.8 V$	-	230	-	$\mu A$
$I_{SHDN}$	Shut Down Current	$EN = 0 V$	-	0.1	1.0	$\mu A$
$\%/\Delta V_{IN}$	Output Voltage Line Regulation	$V_{IN} = 2.5V$ to $6.0V$	-	0.08	-	$\%/V$
$\%/\Delta I_{OUT}$	Output Voltage Load Regulation	$I_{OUT} = 200mA$ to $1A$	-	0.12	-	$\%/A$
$V_{FB}$	FB Reference Voltage	$V_{IN} = 2.5V$ to $6.0V$	0.588	0.600	0.612	V
$I_{FB}$	FB Input Current	$V_{FB} = V_{IN}$	-50	-	50	nA
$R_{DS(ON),P}$	LX High Side PMOS ON Resistance		-	250	-	m $\Omega$
$R_{DS(ON),N}$	LX Low Side NMOS ON Resistance		-	200	-	m $\Omega$
$I_{LIM,P}$	LX High Side PMOS Current Limit		-	1.5	-	A
$V_{EN}$	EN Threshold Voltage		1.1	1.5	2.0	V
$\Delta V_{EN}$	EN Threshold Voltage Hysteresis		-	0.2	-	V
$V_{UVLO}$	Input Under-voltage Lockout Threshold		-	-	2.4	V
$\Delta V_{UVLO}$	Under-voltage Lockout Threshold Hysteresis		-	0.2	-	V
$F_{OSC}$	Oscillator Frequency	$I_{OUT} = 200mA$	-	1.5	-	MHz
$T_{ON,MIN}$	Minimum ON Time		-	50	-	ns
$D_{MAX}$	Maximum Duty Cycle		-	100	-	%
$T_{SD}$	Thermal Shutdown Threshold		-	160	-	$^\circ C$
$\Delta T_{SD}$	Thermal Shutdown Threshold Hysteresis		-	30	-	$^\circ C$

### OPERATION DESCRIPTION

PT1206 is a synchronous buck regulator IC that integrates the PWM control, top and bottom switches on the same die to minimize the switching transition loss and conduction loss. With ultra low  $R_{DS(ON)}$  power switches and proprietary PWM control, this regulator IC can achieve the highest efficiency and the highest switch frequency simultaneously to minimize the external inductor and capacitor size, and thus achieving the minimum solution footprint. The internal softstart time is about 1ms.

### APPLICATION INFORMATION

#### Output Voltage Programming

Choose R1 and R2 to program the proper output voltage. To minimize the power consumption under light loads, it is desirable to choose large resistance values for both R1 and R2. A value of between 100kΩ and 1MΩ is highly recommended for both resistors. If R2=120kΩ is chosen, then R1 can be calculated to be:

$$R_1 = \frac{(V_{OUT} - 0.6) \cdot R_2}{0.6}$$

#### Input Capacitor Selection

With the maximum load current at 2A, the maximum ripple current through input capacitor is about 0.6A-rms. A typical X7R or better grade ceramic capacitor with 6V rating and greater than 4.7μF capacitance can handle this ripple current well. In order to minimize the potential noise problem, this ceramic capacitor need to be placed really close to the IN and GND pins. Care should be taken to minimize the loop area formed by CIN, and IN/GND pins.

#### Output Capacitor Selection

The output capacitor is selected to handle the

output ripple noise requirements. Both steady state ripple and transient requirements must be taken into consideration when selecting this capacitor. For the best performance, it is recommended to use X7R or better grade ceramic capacitor with 6V rating and greater than 10μF capacitance.

#### Inductor Selection

There are several considerations in choosing this inductor.

1) Choose the inductance to provide the desired ripple current. It is suggested to choose the ripple current to be about 40% of the maximum output current. The inductance is calculated as:

$$L = \frac{V_{OUT} \cdot (1 - V_{OUT} / V_{IN,MAX})}{F_{SW} \times I_{OUT,MAX \times 40\%}}$$

Where Fsw is the switching frequency and I<sub>OUT,max</sub> is the maximum load current.

The PT1206 regulator IC is quite tolerant to different ripple current amplitude. Consequently, the final selection of inductance can be slightly off with the calculated value without significantly impact to the performance.

2) The saturation current rating of the inductor must be selected to be greater than the peak inductor current under full load conditions.

$$I_{SAT,MIN} > I_{OUT,MAX} + \frac{V_{OUT} \cdot (1 - V_{OUT} / V_{IN,MAX})}{2 \cdot F_{SW} \cdot L}$$

3) The DCR of the inductor and the core loss at the switching frequency must be low enough to achieve the target efficiency requirement. It is desirable to choose an inductor with DCR<50mΩ to achieve a good overall efficiency.

#### Layout Design

The layout design of PT1206 regulator is relatively simple. For the best efficiency and minimum noise

problems, we should place the following components close to the IC: CIN, L, R1 and R2.

- 1) It is desirable to maximize the PCB copper area connecting to GND pin to achieve the best thermal and noise performance. If the budget allowed, a ground plane is highly desirable.
- 2) CIN must be close to pin IN and GND. The loop area formed by CIN and GND must be minimized.
- 3) The PCB copper area associated with LX pin must be minimized to avoid the potential noise problem.
- 4) The components R1, R2, and the trace connecting to the FB pin must NOT be adjacent to the LX net on the PCB layout to avoid the noise problem.
- 5) If the system chip interfacing with the EN pin has a high impedance state at shutdown mode and the

IN pin is connected directly to a power source such as a Li-ion battery, it is desirable to add a pull down 1M $\Omega$  resistor between the EN and GND pins to prevent the noise from false triggering a turn on to the regulator at shutdown mode.

### Load Transient Considerations

The PT1206 regulator IC integrates the compensation components to achieve good stability and fast transient responses. In some applications, adding a 22pF ceramic cap in parallel with R1 may further speed up the load transient responses and is recommended for applications with large load transient step requirements.

preliminary

### TYPICAL PERFORMANCE CHARACTERISTICS

Efficiency vs Load Current

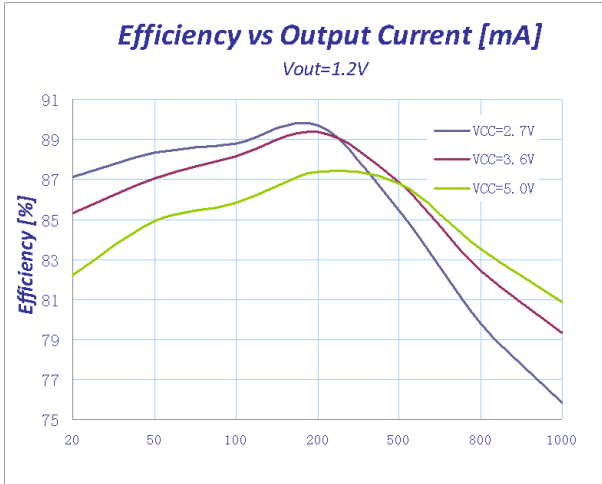

Efficiency vs Load Current

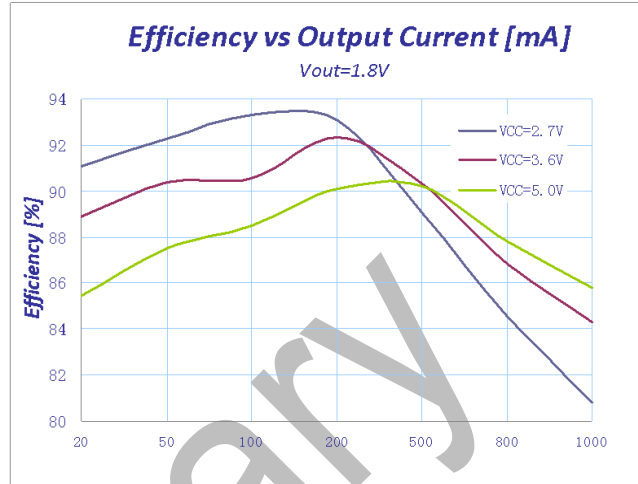

Efficiency vs Load Current

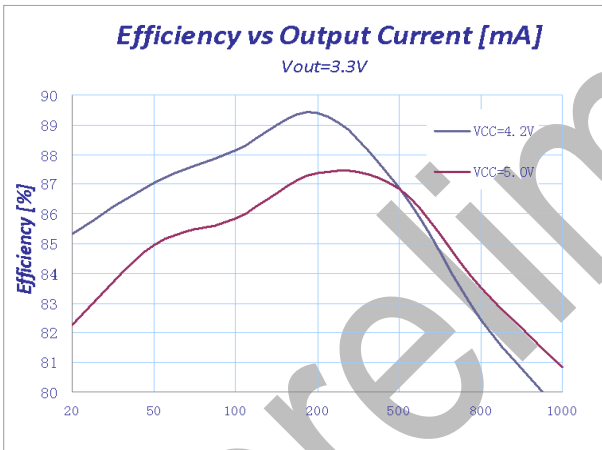

Normal Operation

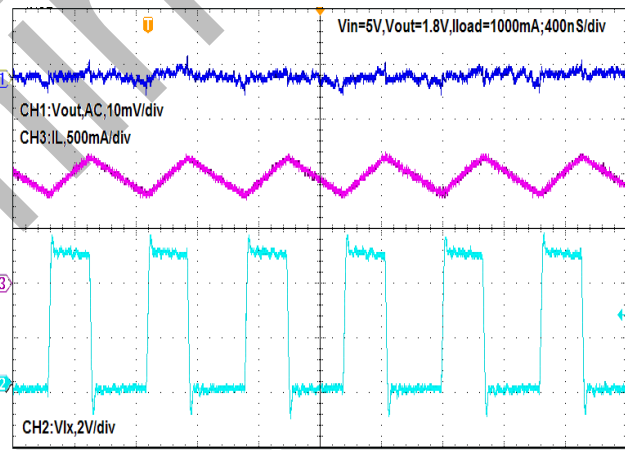

Load Transient

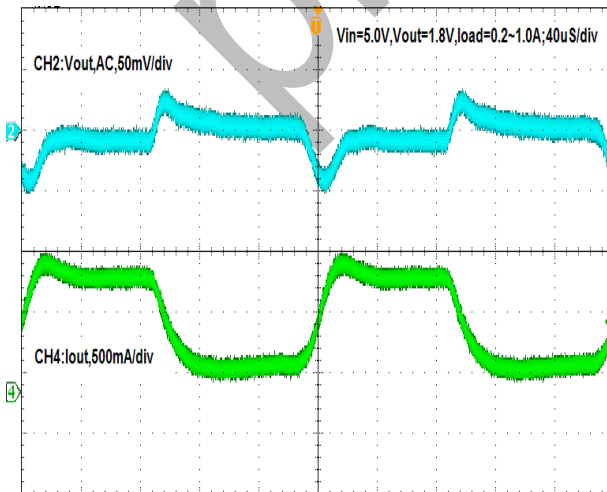

Startup

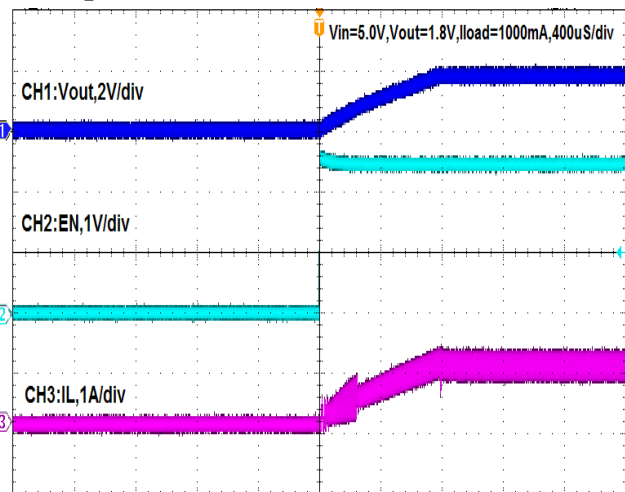

**Shutdown**

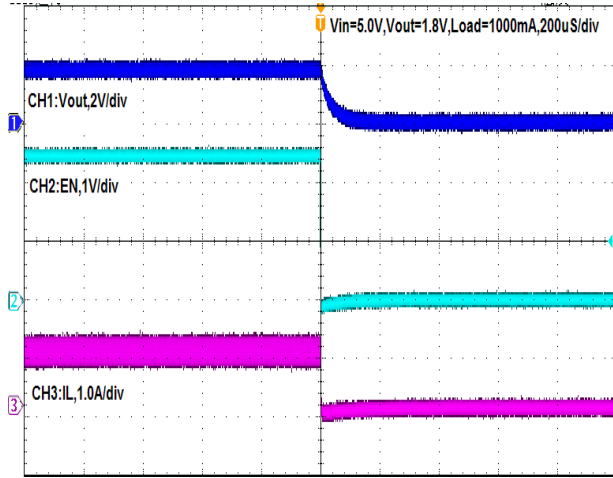



### PACKAGE INFORMATION

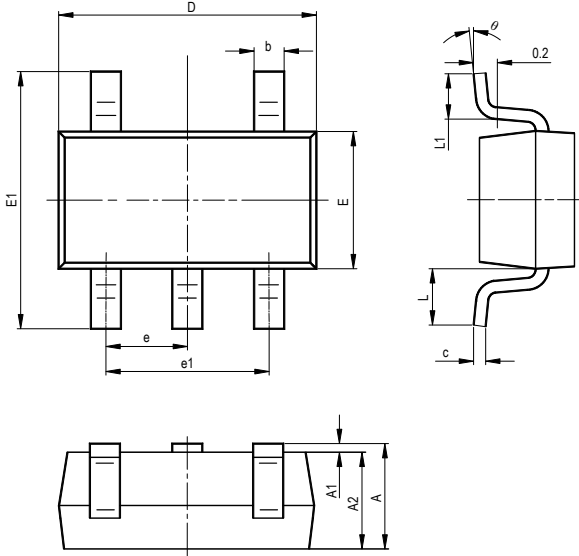

Symbol	Millimeters		Inches	
	Min	Max	Min	Max
A	-	1.450	-	0.057
A1	0	0.150	0	0.006
A2	0.900	1.300	0.035	0.051
b	0.300	0.500	0.012	0.020
c	0.080	0.220	0.003	0.009
D	2.820	3.020	0.111	0.119
E	1.500	1.700	0.059	0.067
E1	2.600	2.950	0.102	0.116
e	0.950TYP		0.037TYP	
e1	1.800	2.000	0.071	0.079
L	0.600REF		0.024REF	
L1	0.300	0.600	0.012	0.024
θ	0°	8°	0°	8°

preliminary