

**NPN SILICON PLANAR EPITAXIAL TRANSISTOR**

**CML1207**

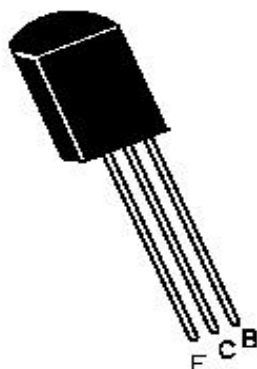

**TO-92L  
Plastic Package**

**Power Amplifier and Switching Applications**

**ABSOLUTE MAXIMUM RATINGS**

DESCRIPTION	SYMBOL	VALUE	UNITS
Collector Base Voltage	$V_{CBO}$	50	V
Collector Emitter Voltage	$V_{CEO}$	50	V
Emitter Base Voltage	$V_{EBO}$	5.0	V
Collector Current	$I_C$	1.0	A
Emitter Current	$I_E$	1.0	A
Collector Power Dissipation @ $T_a=25^\circ\text{C}$	$P_C$	1.0	W
Junction Temperature	$T_j$	150	$^\circ\text{C}$
Storage Temperature Range	$T_{stg}$	- 55 to +150	$^\circ\text{C}$

**ELECTRICAL CHARACTERISTICS ( $T_a=25^\circ\text{C}$  unless specified otherwise)**

DESCRIPTION	SYMBOL	TEST CONDITION	MIN	TYP	MAX	UNITS
Collector Cut Off Current	$I_{CBO}$	$V_{CB}=50\text{V}, I_E=0$			0.1	$\mu\text{A}$
Emitter Cut Off Current	$I_{EBO}$	$V_{EB}=5\text{V}, I_C=0$			0.1	$\mu\text{A}$
Collector Emitter Voltage	$V_{CEO}$	$I_C=1\text{mA}, I_B=0$	50			V
Emitter Base Voltage	$V_{EBO}$	$I_E=1\text{mA}, I_C=0$	5.0			V
DC Current Gain	$h_{FE}$	* $I_C=0.5\text{A}, V_{CE}=2\text{V}$ $I_C=1\text{A}, V_{CE}=2\text{V}$	60 20		240	
Collector Emitter Saturation Voltage	$V_{CE(sat)}$	$I_C=500\text{mA}, I_B=50\text{mA}$ $I_C=1\text{A}, I_B=100\text{mA}$			0.4 0.6	V V
Base Emitter Saturation Voltage	$V_{BE(sat)}$	$I_C=1\text{A}, I_B=100\text{mA}$			1.2	V
Transition Frequency	$f_T$	$I_C=100\text{mA}, V_{CE}=2\text{V}$		100		MHz
Output Capacitance	$C_{ob}$	$I_E=0, V_{CB}=10\text{V}, f=1\text{MHz}$		4.0		pF

**Switching Time**

DESCRIPTION	SYMBOL	TEST CONDITION	MIN	TYP	MAX	UNITS
Turn On Time	$t_{on}$	$V_{CC}=30\text{V}, I_{B1}=-I_{B2}=50\text{mA},$ Duty Cycle $\leq 1\%$		0.1		$\mu\text{s}$
Turn Off Time	$t_{off}$			1.1		$\mu\text{s}$

<b>*<math>h_{FE}</math> Classification</b>	<b>O 60 - 140, Y 120 - 240</b>
--	--------------------------------

CML1207Rev020106E

TO-92L Leaded Plastic Package

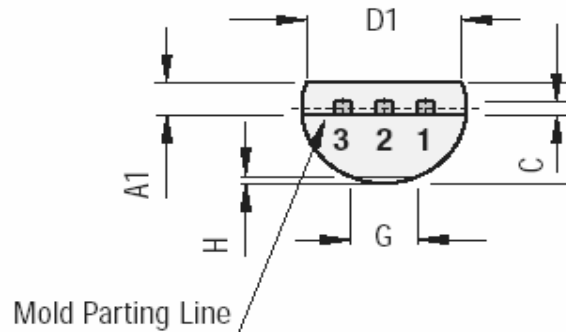
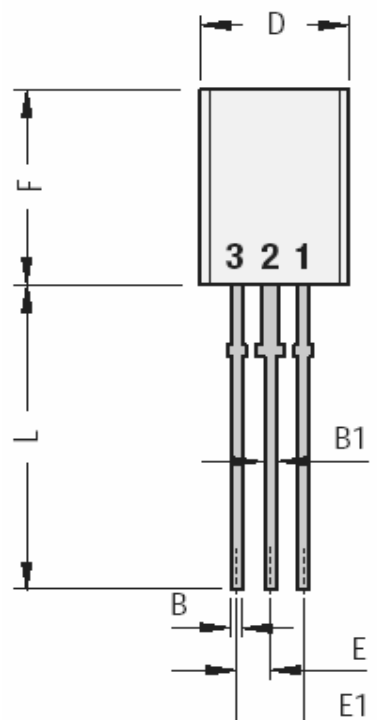

DIM	Min	Max
A	3.70	4.10
A1	1.28	1.58
B	0.35	0.55
B1	0.60	0.80
C	0.35	0.45
D	4.70	5.10
D1	4.00	—

DIM	Min	Max
E	1.27 Typ	
E1	2.44	2.64
F	7.80	8.20
G	—	1.60
H	0.00	0.30
L	13.60	14.20

All Dimensions are in mm

Pin Configurations

CDIL Case Style	Pin 1	Pin 2	Pin 3
TO-92L-1	Base	Collector	Emitter

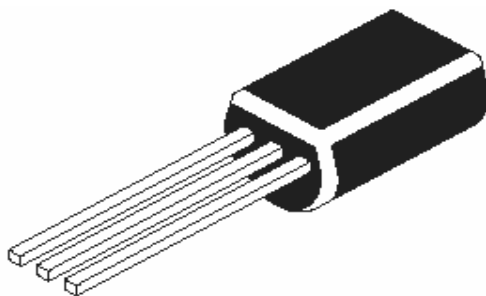

TO-92L Packaging Tape

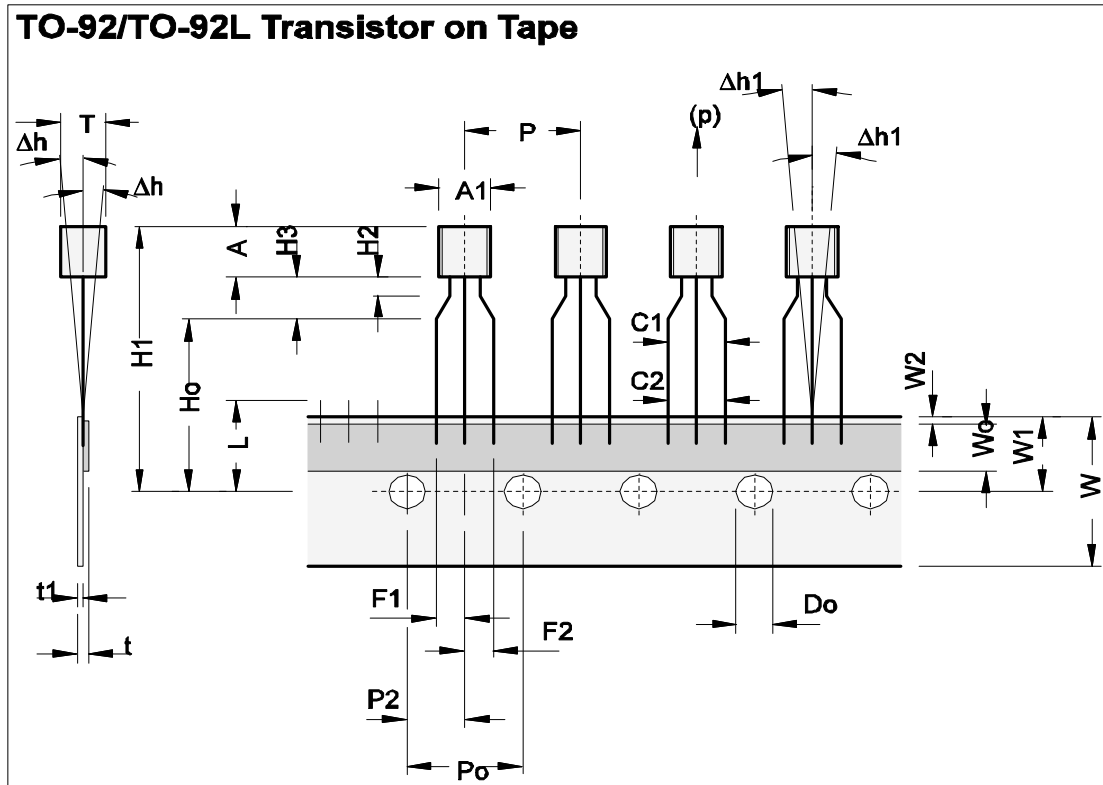

Taping Specifications		TO-92L			
Item description	Symbol	Min	Nom	Max	Tol
Body width	A1	4.7		5.1	
Body height	A	7.8		8.2	
Body thickness	T	3.7		4.1	
Pitch of component <sup>Cr</sup>	P		12.7		±0.3
Feed hole pitch <sup>S1</sup>	Po		12.7		±0.2
Feed hole center to component centre <sup>S2</sup>	P2		6.35		±0.3
Comp. alignment, Side view <sup>S3</sup>	Dh		0		±1.0
Comp. alignment, Front view <sup>S3</sup>	Dh1		0		±1.0
Tape width <sup>Cr</sup>	W		18.0		+1.0 -0.5
Hold down tape width <sup>Cr</sup>	W0		6.0		±0.5
Hole position	W1		9.0		±0.5
Hold-down tape position	W2			1.0	
Lead wire clinch height	Ho		16.0		±0.5
Component height	H1			29.0	
Length of clipped leads	L			11.0	
Feed hole diameter <sup>Cr</sup>	Do		4.0		±0.2
Total tape thickness <sup>S4</sup>	t		0.2		±0.5
Lead-to-lead distance <sup>Cr</sup>	F1, F2	2.2		2.8	
Stand off	H2	0.45		1.45	
Clinch height	H3			4.0	
Lead parallelism <sup>Cr</sup>	C1-C2			0.22	
Pull-out force	(p)	6N			

All Dimensions are in mm

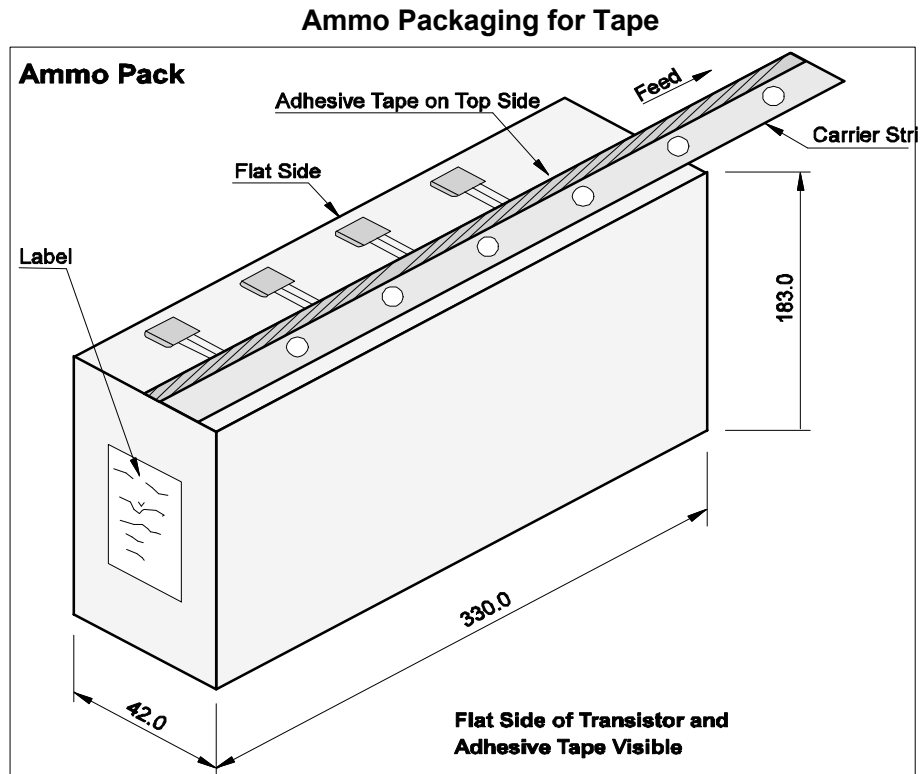

§1 Cumulative pitch error 1.0 mm/20 pitch.

§2 To be measured at bottom of clinch.

§3 At top of body.

§4  $t_1 = 0.3 - 0.6$  mm

**Cr** Critical Dimension.

- Maximum alignment deviation between leads not to be greater than 0.20 mm.
- Maximum non-cumulative variation between tape feed holes shall not exceed 1 mm in 20 pitches.
- Hold down tape not to exceed beyond the edge(s) carrier tape and there shall be no exposure of adhesive.
- No more than 3 consecutive missing components is permitted.
- A tape trailer, having at least three feed holes is required after the last component.
- Splices shall not interfere with the sprocket feed holes.

## Packaging Information

Package/ Case Type	Packaging Type	Std. Packing Qty	Inner Carton			Outer Carton		
			Qty	Size L x W x H (cm)	Gross Weight (Kg)	Qty	Size L x W x H (cm)	Gross Weight (Kg)
TO-92L	Bulk	5,000	5K	19 x 19 x 8	1.2	80K	43 x 38 x 34	30.0
	T & A	2,000	2K	35 x 4.5 x 20	0.72	40K	44 x 38 x 34	16.0

All Dimensions are in mm

Bulk: Lose in Poly bags

T & A: Tube and Ammo Pack

## RoHS Compliant Device Part Numbers and Marking on CDIL Devices and Packaging

Packing Slip (PM) and inner carton boxes of all RoHS Compliant Semiconductor Devices carry a ' T ' mark in green colour.

The marking on the CDIL's RoHS Compliant Devices will be as specified below:

Documentation – Standard CDIL part numbers will be prefixed with ' T ' and specified on the Invoice and Shipping Documents.

Physical Marking - The marking on these Devices shall also carry the 'T' mark, generally as a prefix. However, in case of physical space constraint on the package, 'T' mark may be put as a suffix or in the next line.

**Component Disposal Instructions**

1. CDIL Semiconductor Devices are RoHS compliant, customers are requested to please dispose as per prevailing Environmental Legislation of their Country.
2. In Europe, please dispose as per EU Directive 2002/96/EC on Waste Electrical and Electronic Equipment (WEEE).

**Disclaimer**

The product information and the selection guides facilitate selection of the CDIL's Semiconductor Device(s) best suited for application in your product(s) as per your requirement. It is recommended that you completely review our Data Sheet(s) so as to confirm that the Device(s) meet functionality parameters for your application. The information furnished in the Data Sheet and on the CDIL Web Site/CD are believed to be accurate and reliable. CDIL however, does not assume responsibility for inaccuracies or incomplete information. Furthermore, CDIL does not assume liability whatsoever, arising out of the application or use of any CDIL product; neither does it convey any license under its patent rights nor rights of others. These products are not designed for use in life saving/support appliances or systems. CDIL customers selling these products (either as individual Semiconductor Devices or incorporated in their end products), in any life saving/support appliances or systems or applications do so at their own risk and CDIL will not be responsible for any damages resulting from such sale(s).

CDIL strives for continuous improvement and reserves the right to change the specifications of its products without prior notice.



CDIL is a registered Trademark of  
Continental Device India Limited

C-120 Naraina Industrial Area, New Delhi 110 028, India.

Telephone + 91-11-2579 6150, 4141 1112 Fax + 91-11-2579 5290, 4141 1119

email@cdil.com www.cdilsemi.com