

isc Silicon PNP Power Transistor

2SB1289

DESCRIPTION

- High Collector Current:: $I_C = -7A$
- Low Collector Saturation Voltage
: $V_{CE(sat)} = -1.0V(\text{Max}) @ I_C = -4A$
- Wide Area of Safe Operation
- Complement to Type 2SD1580

APPLICATIONS

- Designed for low frequency power amplifier applications.

ABSOLUTE MAXIMUM RATINGS($T_a=25^\circ\text{C}$)

SYMBOL	PARAMETER	VALUE	UNIT
V_{CBO}	Collector-Base Voltage	-80	V
V_{CEO}	Collector-Emitter Voltage	-80	V
V_{EBO}	Emitter-Base Voltage	-5	V
I_C	Collector Current-Continuous	-7	A
I_{CM}	Collector Current-Peak	-10	A
P_C	Total Power Dissipation @ $T_C=25^\circ\text{C}$	40	W
T_J	Junction Temperature	150	$^\circ\text{C}$
T_{stg}	Storage Temperature Range	-55~150	$^\circ\text{C}$

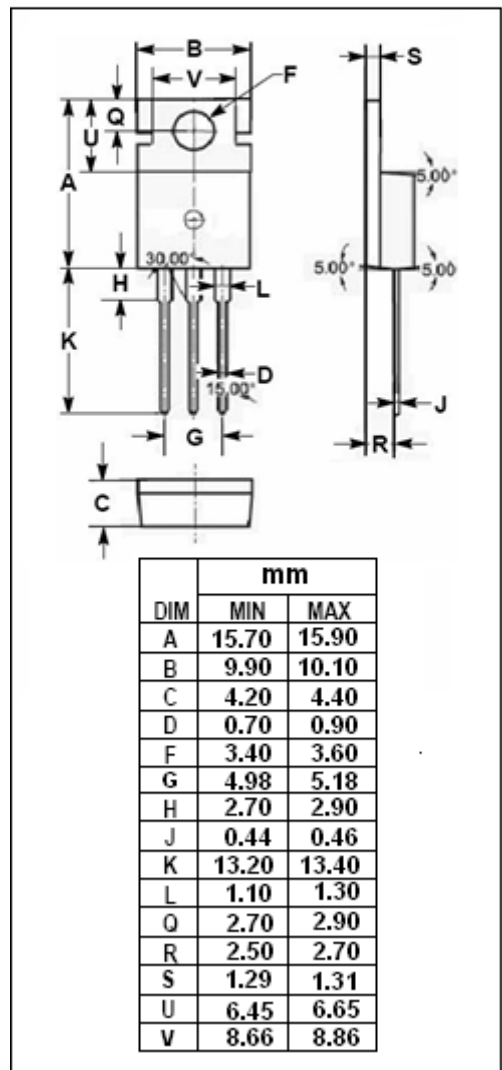
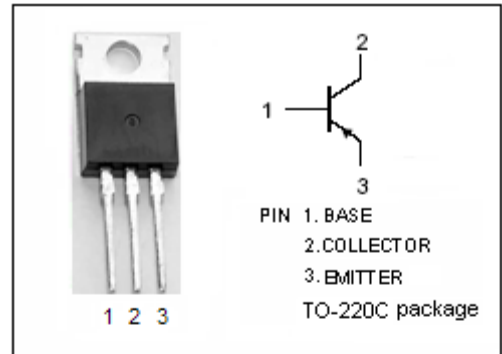

isc Silicon PNP Power Transistor

2SB1289

ELECTRICAL CHARACTERISTICS

 $T_C=25^{\circ}\text{C}$ unless otherwise specified

SYMBOL	PARAMETER	CONDITIONS	MIN	TYP.	MAX	UNIT
$V_{(BR)CEO}$	Collector-Emitter Breakdown Voltage	$I_C = -1\text{mA}; I_B = 0$	-80			V
$V_{(BR)CBO}$	Collector-Base Breakdown Voltage	$I_C = -50\ \mu\text{A}; I_E = 0$	-80			V
$V_{(BR)EBO}$	Emitter-Base Breakdown Voltage	$I_E = -50\ \mu\text{A}; I_C = 0$	-5			V
$V_{CE(sat)}$	Collector-Emitter Saturation Voltage	$I_C = -4\text{A}; I_B = -0.4\text{A}$			-1.0	V
$V_{BE(sat)}$	Base-Emitter Saturation Voltage	$I_C = -4\text{A}; I_B = -0.4\text{A}$			-1.5	V
I_{CBO}	Collector Cutoff Current	$V_{CB} = -80\text{V}; I_E = 0$			-10	μA
I_{EBO}	Emitter Cutoff Current	$V_{EB} = -4\text{V}; I_C = 0$			-10	μA
h_{FE}	DC Current Gain	$I_C = -1\text{A}; V_{CE} = -5\text{V}$	60		320	
C_{OB}	Output Capacitance	$I_E = 0; V_{CB} = -10\text{V}; f = 1\text{MHz}$		200		pF
f_T	Current-Gain—Bandwidth Product	$I_E = 0.5\text{A}; V_{CE} = -5\text{V}$		12		MHz

◆ h_{FE} Classifications

D	E	F
60-120	100-200	160-320