

DWC. NO.		221-510-0007G	
REV	DESCRIPTION	BY DATE	APPD
A	ECN 2384	JHM 8/3/00	JJY

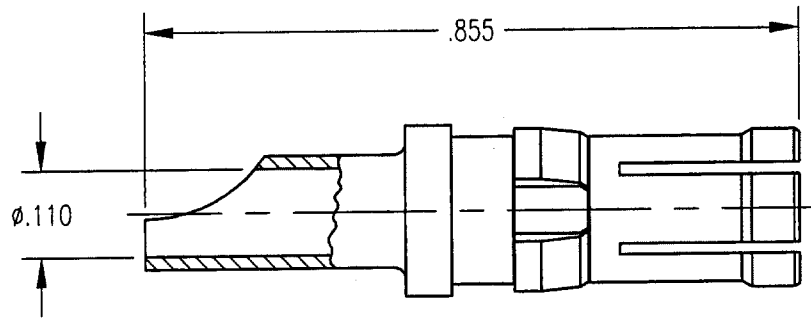

NOTES:

1. MATERIAL:
 BODY: BERYLLIUM COPPER PER ASTM B196.
 CLIP RING: BERYLLIUM COPPER PER ASTM B194.
2. FINISH:
 BODY: .000030 MIN. GOLD PER MIL-G-45204 OVER
 .000050 MIN. NICKEL PER QQ-N-290.
 CLIP RING: .000050 NICKEL MIN.
3. ELECTRICAL:
 CURRENT RATING: 20 AMPS MIN.

PER ASME Y14.5M-1994 UNLESS OTHERWISE SPECIFIED: DIMENSIONS ARE IN INCHES (MM)				Litton Winchester/Retconn			
TOLERANCES: DECIMALS .XX ± .01/0.254 .XXX ± .005/0.127 ANGLES ± 2°				400 Park Road Watertown, Connecticut 06795			
CUSTOMER DRAWING				TITLE HIGH POWER RECEPTACLE			
DRAWN JED	DATE 4/21/97	CHECKED JMC	DATE 4/21/97	SMT. OF 1 1		REV. A	
APPROVED AT		DATE 4/21/97		APPROVED AT		DATE 4/21/97	
A				221-510-0007G			