



TSV6390, TSV6390A, TSV6391, TSV6391A

Micropower (60 μ A), wide bandwidth (2.4 MHz) CMOS op-amps

Features

- Low offset voltage: 500 μ V max (A version)
- Low power consumption: 60 μ A typ at 5 V
- Low supply voltage: 1.5 V – 5.5 V
- Gain bandwidth product: 2.4 MHz typical
- Stable in gain configuration (-3 or +4)
- Low power shutdown mode: 5 nA typical
- High output current: 63 mA at $V_{CC} = 5$ V
- Low input bias current: 1 pA typical
- Rail-to-rail input and output
- Extended temperature range: -40°C to +125°C
- 4 kV human body model

Applications

- Battery-powered applications
- Portable devices
- Signal conditioning
- Active filtering
- Medical instrumentation

Description

The TSV6390 and TSV6391 devices are single operational amplifiers offering low voltage, low power operation and rail-to-rail input and output.

With a very low input bias current and low offset voltage (500 μ V maximum for the A version), the TSV6390 and TSV6391 are ideal for applications requiring precision. The devices can operate at power supplies ranging from 1.5 to 5.5 V, and are therefore ideal for battery-powered devices, extending battery life.

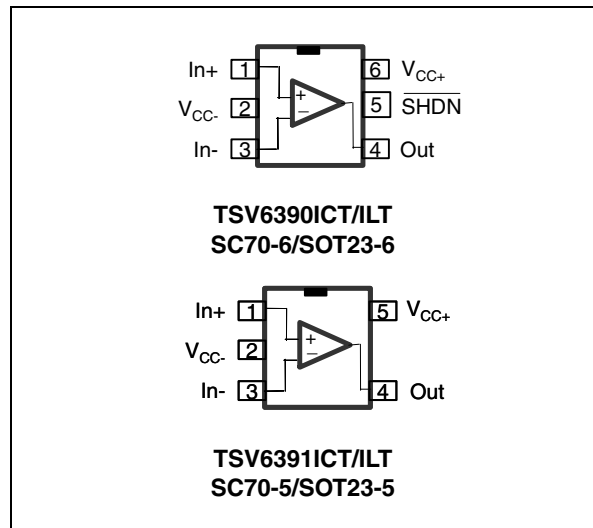

When used with a gain (above -3 or +4), these products feature an excellent speed/power consumption ratio, offering a 2.4 MHz gain bandwidth product while consuming only 60 μ A at a 5 V supply voltage.

The TSV6390 comes with a shutdown function.

Both the TSV6390 and TSV6391 have a high tolerance to ESD, sustaining 4 kV for the human body model.

Additionally, they are offered in micropackages, SC70-6 and SOT23-6 for the TSV6390 and SC70-5 and SOT23-5 for the TSV6391. They are guaranteed for industrial temperature ranges from -40° C to +125° C.

All these features combined make the TSV6390 and TSV6391 ideal for sensor interfaces, battery-supplied and portable applications, as well as active filtering.

Contents

1	Absolute maximum ratings and operating conditions	3
2	Electrical characteristics	4
3	Application information	11
3.1	Operating voltages	11
3.2	Rail-to-rail input	11
3.3	Rail-to-rail output	11
3.4	Shutdown function (TSV6390)	11
3.5	Optimization of DC and AC parameters	13
3.6	Driving resistive and capacitive loads	13
3.7	PCB layouts	13
3.8	Macromodel	13
4	Package information	14
4.1	SOT23-5 package mechanical data	15
4.2	SOT23-6 package mechanical data	16
4.3	SC70-5 (or SOT323-5) package mechanical data	17
4.4	SC70-6 (or SOT323-6) package mechanical data	18
5	Ordering information	20
6	Revision history	21

1 Absolute maximum ratings and operating conditions

Table 1. Absolute maximum ratings (AMR)

Symbol	Parameter	Value	Unit
V_{CC}	Supply voltage ⁽¹⁾	6	V
V_{id}	Differential input voltage ⁽²⁾	$\pm V_{CC}$	V
V_{in}	Input voltage ⁽³⁾	$V_{CC-} - 0.2$ to $V_{CC+} + 0.2$	V
I_{in}	Input current ⁽⁴⁾	10	mA
\overline{SHDN}	Shutdown voltage ⁽³⁾	$V_{CC-} - 0.2$ to $V_{CC+} + 0.2$	V
T_{stg}	Storage temperature	-65 to +150	°C
R_{thja}	Thermal resistance junction to ambient ⁽⁵⁾⁽⁶⁾		
	SC70-5	205	°C/W
	SOT23-5	250	
	SOT23-6	240	
SC70-6	232		
T_j	Maximum junction temperature	150	°C
ESD	HBM: human body model ⁽⁷⁾	4	kV
	MM: machine model ⁽⁸⁾	300	V
	CDM: charged device model ⁽⁹⁾	1.5	kV
	Latch-up immunity	200	mA

1. All voltage values, except differential voltages, are with respect to network ground terminal.
2. Differential voltages are the non-inverting input terminal with respect to the inverting input terminal.
3. $V_{CC-} - V_{in}$ must not exceed 6 V, V_{in} must not exceed 6 V.
4. Input current must be limited by a resistor in series with the inputs.
5. Short-circuits can cause excessive heating and destructive dissipation.
6. R_{th} are typical values.
7. Human body model: 100 pF discharged through a 1.5 kΩ resistor between two pins of the device, done for all couples of pin combinations with other pins floating.
8. Machine model: a 200 pF capacitor is charged to the specified voltage, then discharged directly between two pins of the device with no external series resistor (internal resistor < 5 Ω), done for all couples of pin combinations with other pins floating.
9. Charged device model: all pins plus package are charged together to the specified voltage and then discharged directly to the ground.

Table 2. Operating conditions

Symbol	Parameter	Value	Unit
V_{CC}	Supply voltage	1.5 to 5.5	V
V_{icm}	Common mode input voltage range	$V_{CC-} - 0.1$ to $V_{CC+} + 0.1$	V
T_{oper}	Operating free air temperature range	-40 to +125	°C

2 Electrical characteristics

Table 3. Electrical characteristics at $V_{CC+} = +1.8\text{ V}$ with $V_{CC-} = 0\text{ V}$, $V_{icm} = V_{CC}/2$, $T_{amb} = 25^\circ\text{ C}$ and R_L connected to $V_{CC}/2$ (unless otherwise specified)

Symbol	Parameter	Conditions	Min.	Typ.	Max.	Unit
DC performance						
V_{io}	Offset voltage	TSV6390-TSV6391 TSV6390A-TSV6391A			3 0.5	mV
		$T_{min} < T_{op} < T_{max}$ TSV6390-TSV6391 TSV6390A-TSV6391A			4.5 2	
DV_{io}	Input offset voltage drift			2		$\mu\text{V}/^\circ\text{C}$
I_{io}	Input offset current ⁽¹⁾ ($V_{out} = V_{CC}/2$)			1	10	pA
		$T_{min} < T_{op} < T_{max}$		1	100	
I_{ib}	Input bias current ⁽¹⁾ ($V_{out} = V_{CC}/2$)			1	10	pA
		$T_{min} < T_{op} < T_{max}$		1	100	
CMR	Common mode rejection ratio $20 \log (\Delta V_{ic}/\Delta V_{io})$	0 V to 1.8 V, $V_{out} = 0.9\text{ V}$	53	74		dB
		$T_{min} < T_{op} < T_{max}$	51			
A_{vd}	Large signal voltage gain	$R_L = 10\text{ k}\Omega$, $V_{out} = 0.5\text{ V to }1.3\text{ V}$	85	95		dB
		$T_{min} < T_{op} < T_{max}$	80			
V_{OH}	High level output voltage	$R_L = 10\text{ k}\Omega$	35	5		mV
		$T_{min} < T_{op} < T_{max}$	50			
V_{OL}	Low level output voltage	$R_L = 10\text{ k}\Omega$		4	35	mV
		$T_{min} < T_{op} < T_{max}$			50	
I_{out}	I_{sink}	$V_{out} = 1.8\text{ V}$	6	12		mA
		$T_{min} < T_{op} < T_{max}$	4			
	I_{source}	$V_{out} = 0\text{ V}$	6	10		mA
		$T_{min} < T_{op} < T_{max}$	4			
I_{CC}	Supply current SHDN = V_{CC}	No load, $V_{out} = V_{CC}/2$	40	50	60	μA
		$T_{min} < T_{op} < T_{max}$			62	
AC performance						
GBP	Gain bandwidth product	$R_L = 10\text{ k}\Omega$, $C_L = 100\text{ pF}$		2		MHz
Gain	Minimum gain for stability	Phase margin = 60° , $R_f = 10\text{ k}\Omega$, $R_L = 10\text{ k}\Omega$, $C_L = 20\text{ pF}$		+4 -3		V/V
SR	Slew rate	$R_L = 10\text{ k}\Omega$, $C_L = 100\text{ pF}$, $V_{out} = 0.5\text{ V to }1.3\text{ V}$		0.7		V/ μs
e_n	Equivalent input noise voltage	$f = 1\text{ kHz}$ $f = 10\text{ kHz}$		60 33		$\frac{\text{nV}}{\sqrt{\text{Hz}}}$

1. Guaranteed by design.

Table 4. Shutdown characteristics $V_{CC} = 1.8\text{ V}$ (TSV6390)

Symbol	Parameter	Conditions	Min.	Typ.	Max.	Unit
DC performance						
I_{CC}	Supply current in shutdown mode (all operators)	$\overline{\text{SHDN}} = V_{CC-}$		2.5	50	nA
		$T_{\min} < T_{\text{op}} < 85^\circ\text{C}$			200	nA
		$T_{\min} < T_{\text{op}} < 125^\circ\text{C}$			1.5	μA
t_{on}	Amplifier turn-on time	$R_L = 2\text{ k}\Omega$ $V_{\text{out}} = V_{CC-}$ to $V_{CC-} + 0.2\text{ V}$		300		ns
t_{off}	Amplifier turn-off time	$R_L = 2\text{ k}\Omega$ $V_{\text{out}} = V_{CC+} - 0.5\text{ V}$ to $V_{CC+} - 0.7\text{ V}$		20		ns
V_{IH}	$\overline{\text{SHDN}}$ logic high		1.3			V
V_{IL}	$\overline{\text{SHDN}}$ logic low				0.5	V
I_{IH}	$\overline{\text{SHDN}}$ current high	$\overline{\text{SHDN}} = V_{CC+}$		10		μA
I_{IL}	$\overline{\text{SHDN}}$ current low	$\overline{\text{SHDN}} = V_{CC-}$		10		μA
I_{OLeak}	Output leakage in shutdown mode	$\overline{\text{SHDN}} = V_{CC-}$		50		μA
		$T_{\min} < T_{\text{op}} < T_{\text{max}}$		1		nA

Table 5. $V_{CC+} = +3.3\text{ V}$, $V_{CC-} = 0\text{ V}$, $V_{icm} = V_{CC}/2$, $T_{amb} = 25^\circ\text{ C}$, R_L connected to $V_{CC}/2$
(unless otherwise specified)

Symbol	Parameter	Conditions	Min.	Typ.	Max.	Unit
DC performance						
V_{io}	Offset voltage	TSV6390-TSV6391 TSV6390A-TSV6391A			3 0.5	mV
		$T_{min} < T_{op} < T_{max}$ TSV6390-TSV6391 TSV6390A-TSV6391A			4.5 2	
DV_{io}	Input offset voltage drift			2		$\mu\text{V}/^\circ\text{C}$
I_{io}	Input offset current ⁽¹⁾			1	10	pA
		$T_{min} < T_{op} < T_{max}$		1	100	
I_{ib}	Input bias current ⁽¹⁾			1	10	pA
		$T_{min} < T_{op} < T_{max}$		1	100	
CMR	Common mode rejection ratio $20 \log (\Delta V_{ic}/\Delta V_{io})$	0 V to 3.3 V, $V_{out} = 1.65\text{ V}$	57	79		dB
		$T_{min} < T_{op} < T_{max}$	53			
A_{vd}	Large signal voltage gain	$R_L = 10\text{ k}\Omega$, $V_{out} = 0.5\text{ V to } 2.8\text{ V}$	88	98		dB
		$T_{min} < T_{op} < T_{max}$	83			
V_{OH}	High level output voltage	$R_L = 10\text{ k}\Omega$	35	6		mV
		$T_{min} < T_{op} < T_{max}$	50			
V_{OL}	Low level output voltage	$R_L = 10\text{ k}\Omega$		7	35	mV
		$T_{min} < T_{op} < T_{max}$			50	
I_{out}	I_{sink}	$V_{out} = 3.3\text{ V}$	23	45		mA
		$T_{min} < T_{op} < T_{max}$	20	42		
	I_{source}	$V_{out} = 0\text{ V}$	23	38		mA
		$T_{min} < T_{op} < T_{max}$	20			
I_{CC}	Supply current $\overline{\text{SHDN}} = V_{CC}$	No load, $V_{out} = V_{CC}/2$	43	55	64	μA
		$T_{min} < T_{op} < T_{max}$			66	μA
AC performance						
GBP	Gain bandwidth product	$R_L = 10\text{ k}\Omega$, $C_L = 100\text{ pF}$		2.2		MHz
Gain	Minimum gain for stability	Phase margin = 60° , $R_f = 10\text{ k}\Omega$, $R_L = 10\text{ k}\Omega$, $C_L = 20\text{ pF}$,		+4 -3		V/V
SR	Slew rate	$R_L = 10\text{ k}\Omega$, $C_L = 100\text{ pF}$, $V_{out} = 0.5\text{ V to } 2.8\text{ V}$		0.9		V/ μs
e_n	Equivalent input noise voltage	$f = 1\text{ kHz}$		65		$\frac{\text{nV}}{\sqrt{\text{Hz}}}$

1. Guaranteed by design.

Table 6. Electrical characteristics at $V_{CC+} = +5\text{ V}$ with $V_{CC-} = 0\text{ V}$, $V_{icm} = V_{CC}/2$, $T_{amb} = 25^\circ\text{ C}$ and R_L connected to $V_{CC}/2$ (unless otherwise specified)

Symbol	Parameter	Conditions	Min.	Typ.	Max.	Unit
DC performance						
V_{io}	Offset voltage	TSV6390-TSV6391 TSV6390A-TSV6391A			3 0.5	mV
		$T_{min} < T_{op} < T_{max}$ TSV6390-TSV6391 TSV6390A-TSV6391A			4.5 2	mV
DV_{io}	Input offset voltage drift			2		$\mu\text{V}/^\circ\text{C}$
I_{io}	Input offset current ⁽¹⁾ ($V_{out} = V_{CC}/2$)			1	10	pA
		$T_{min} < T_{op} < T_{max}$		1	100	
I_{ib}	Input bias current ⁽¹⁾ ($V_{out} = V_{CC}/2$)			1	10	pA
		$T_{min} < T_{op} < T_{max}$		1	100	
CMR	Common mode rejection ratio $20 \log(\Delta V_{io}/\Delta V_{io})$	0 V to 5 V, $V_{out} = 2.5\text{ V}$	60	80		dB
		$T_{min} < T_{op} < T_{max}$	55			
SVR	Supply voltage rejection ratio $20 \log(\Delta V_{CC}/\Delta V_{io})$	$V_{CC} = 1.8\text{ to }5\text{ V}$	75	93		dB
		$T_{min} < T_{op} < T_{max}$	73			
A_{vd}	Large signal voltage gain	$R_L = 10\text{ k}\Omega$, $V_{out} = 0.5\text{ V to }4.5\text{ V}$	89	98		dB
		$T_{min} < T_{op} < T_{max}$	84			
V_{OH}	High level output voltage	$R_L = 10\text{ k}\Omega$	35	7		mV
		$T_{min} < T_{op} < T_{max}$	50			
V_{OL}	Low level output voltage	$R_L = 10\text{ k}\Omega$		6	35	mV
		$T_{min} < T_{op} < T_{max}$			50	
I_{out}	I_{sink}	$V_{out} = 5\text{ V}$	40	65		mA
		$T_{min} < T_{op} < T_{max}$	35			
	I_{source}	$V_{out} = 0\text{ V}$	40	72		mA
		$T_{min} < T_{op} < T_{max}$	35			
I_{CC}	Supply current $\overline{\text{SHDN}} = V_{CC}$	No load, $V_{out} = V_{CC}/2$	50	60	69	μA
		$T_{min} < T_{op} < T_{max}$			72	
AC performance						
GBP	Gain bandwidth product	$R_L = 10\text{ k}\Omega$, $C_L = 100\text{ pF}$		2.4		MHz
Gain	Minimum gain for stability	Phase margin = 60° , $R_f = 10\text{ k}\Omega$, $R_L = 10\text{ k}\Omega$, $C_L = 20\text{ pF}$,		+4 -3		V/V
SR	Slew rate	$R_L = 10\text{ k}\Omega$, $C_L = 100\text{ pF}$		1.1		V/ μs

Table 6. Electrical characteristics at $V_{CC+} = +5\text{ V}$ with $V_{CC-} = 0\text{ V}$, $V_{icm} = V_{CC}/2$, $T_{amb} = 25^\circ\text{ C}$ and R_L connected to $V_{CC}/2$ (unless otherwise specified) (continued)

Symbol	Parameter	Conditions	Min.	Typ.	Max.	Unit
e_n	Equivalent input noise voltage	$f = 1\text{ kHz}$ $f = 10\text{ kHz}$		60 33		$\frac{\text{nV}}{\sqrt{\text{Hz}}}$
THD+N	Total harmonic distortion + noise	$A_v = -10$, $f_{in} = 1\text{ kHz}$, $R = 100\text{ k}\Omega$, $V_{icm} = V_{CC}/2$, $V_{in} = 40\text{ mVpp}$		0.11		%

1. Guaranteed by design.

Table 7. Shutdown characteristics $V_{CC} = 5\text{ V}$ (TSV6390)

Symbol	Parameter	Conditions	Min.	Typ.	Max.	Unit
DC performance						
I_{CC}	Supply current in shutdown mode (all operators)	$\overline{\text{SHDN}} = V_{CC-}$		5	50	nA
		$T_{min} < T_{op} < 85^\circ\text{ C}$			200	nA
		$T_{min} < T_{op} < 125^\circ\text{ C}$			1.5	μA
t_{on}	Amplifier turn-on time	$R_L = 2\text{ k}\Omega$ $V_{out} = V_{CC-}$ to $V_{CC-} + 0.2\text{ V}$		300		ns
t_{off}	Amplifier turn-off time	$R_L = 2\text{ }\Omega$, $V_{out} = V_{CC+} - 0.5\text{ V}$ to $V_{CC+} - 0.7\text{ V}$		30		ns
V_{IH}	$\overline{\text{SHDN}}$ logic high		4.5			V
V_{IL}	$\overline{\text{SHDN}}$ logic low				0.5	V
I_{IH}	$\overline{\text{SHDN}}$ current high	$\overline{\text{SHDN}} = V_{CC+}$		10		μA
I_{IL}	$\overline{\text{SHDN}}$ current low	$\overline{\text{SHDN}} = V_{CC-}$		10		μA
I_{OLeak}	Output leakage in shutdown mode	$\overline{\text{SHDN}} = V_{CC-}$		50		μA
		$T_{min} < T_{op} < T_{max}$		1		nA

Figure 1. Supply current vs. supply voltage at $V_{icm} = V_{CC}/2$

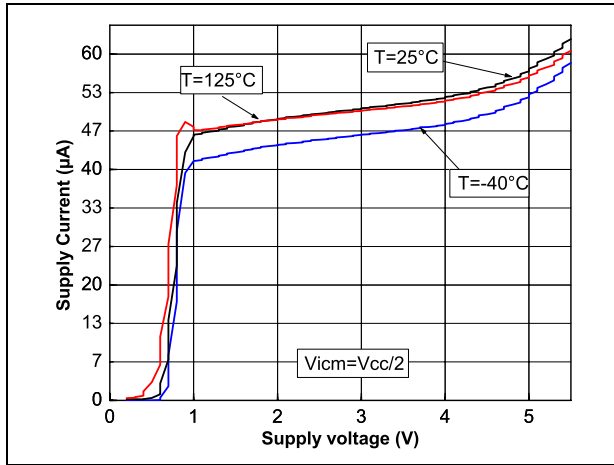

Figure 2. Output current vs. output voltage at $V_{CC} = 1.5 V$

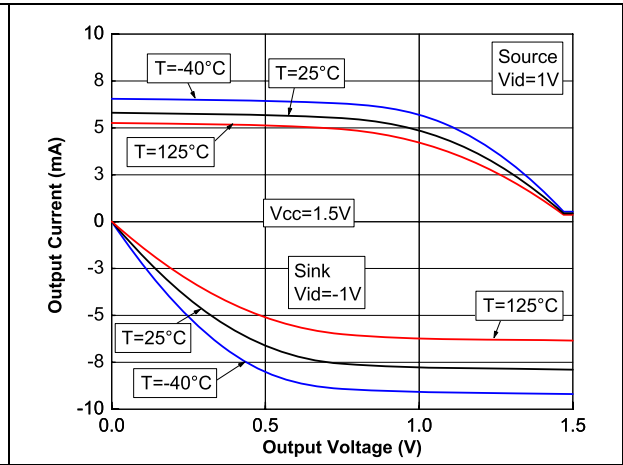

Figure 3. Output current vs. output voltage at $V_{CC} = 5 V$

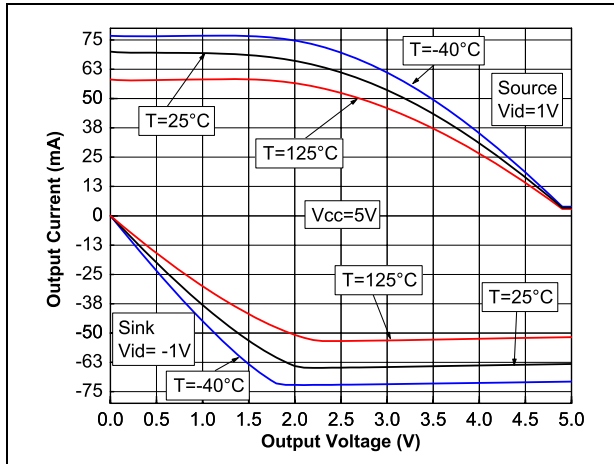

Figure 4. Peaking at closed loop gain = -10

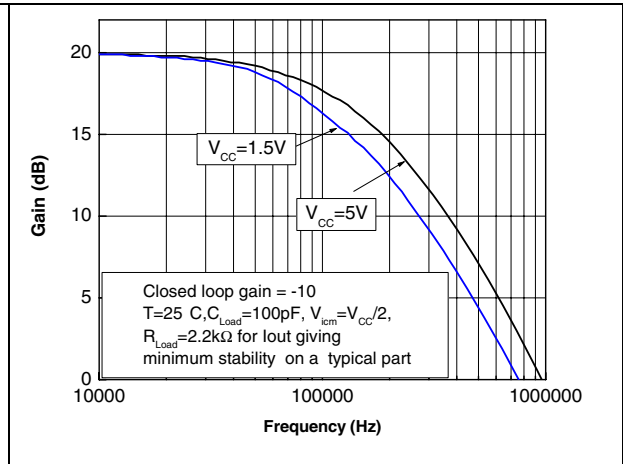

Figure 5. Peaking at closed loop gain = -3 at $V_{CC} = 1.5 V$

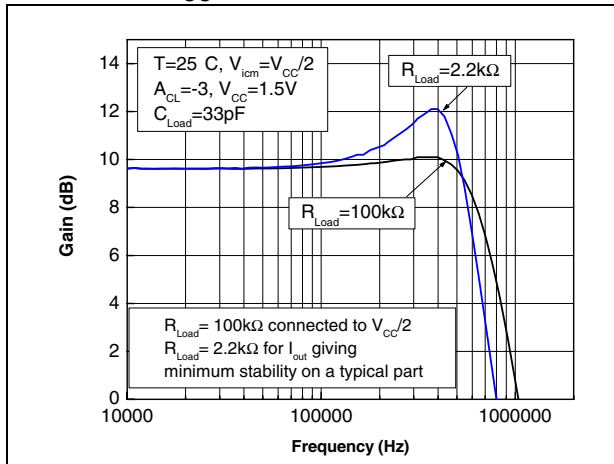

Figure 6. Peaking at closed loop gain = -3 at $V_{CC} = 5 V$

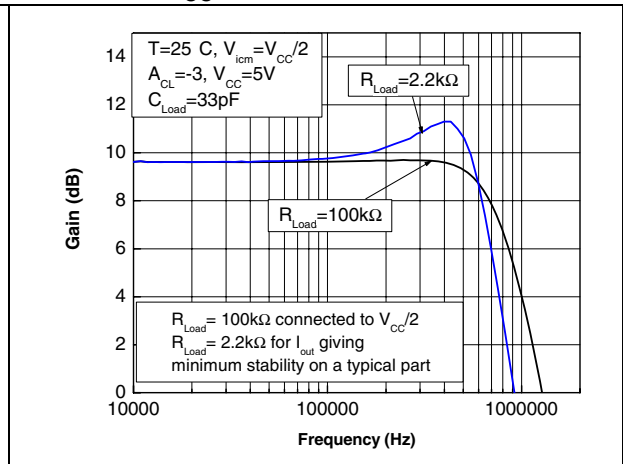

Figure 7. Positive slew rate vs. supply voltage

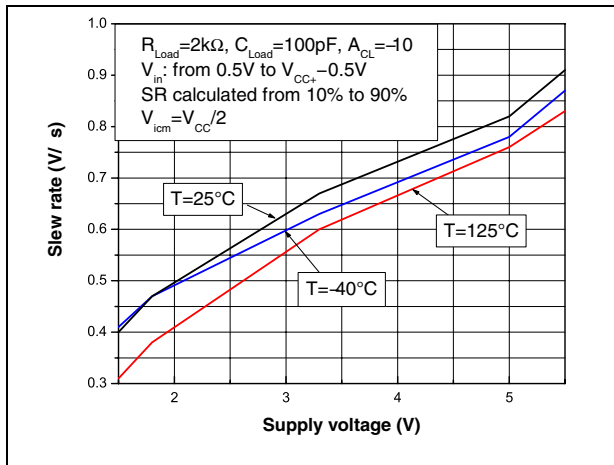

Figure 8. Negative slew rate vs. supply voltage

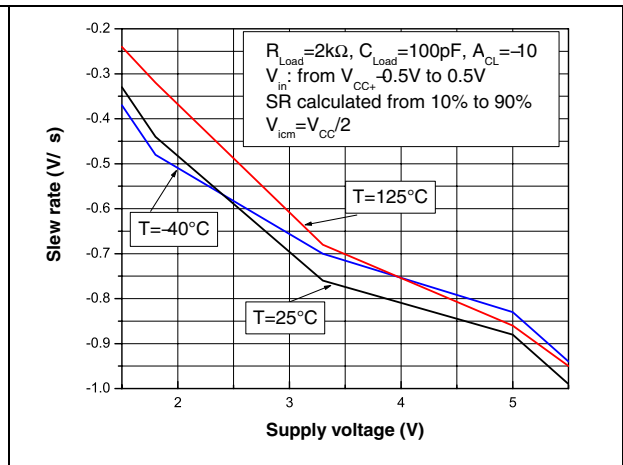

Figure 9. Distortion + noise vs. output voltage at V_{CC} = 1.8 V

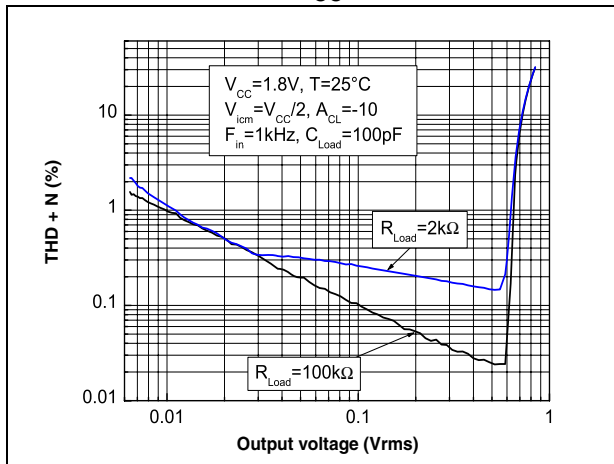

Figure 10. Distortion + noise vs. output voltage at V_{CC} = 5 V

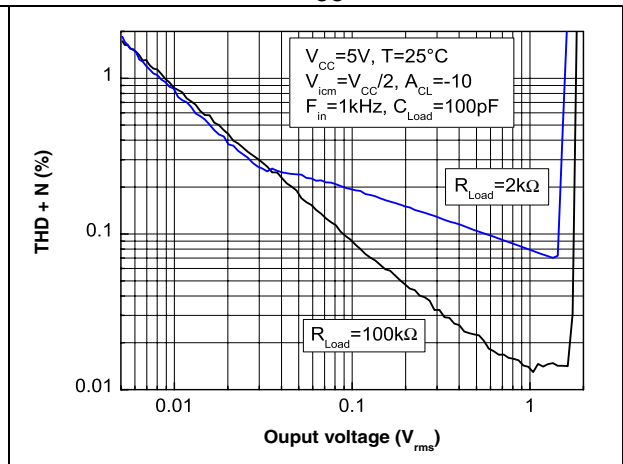

Figure 11. Slew rate timing

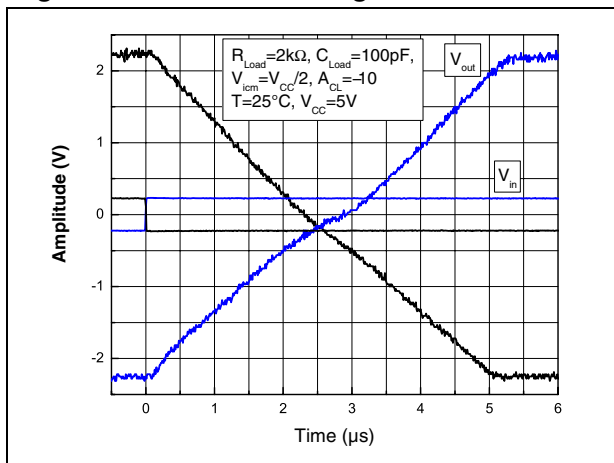
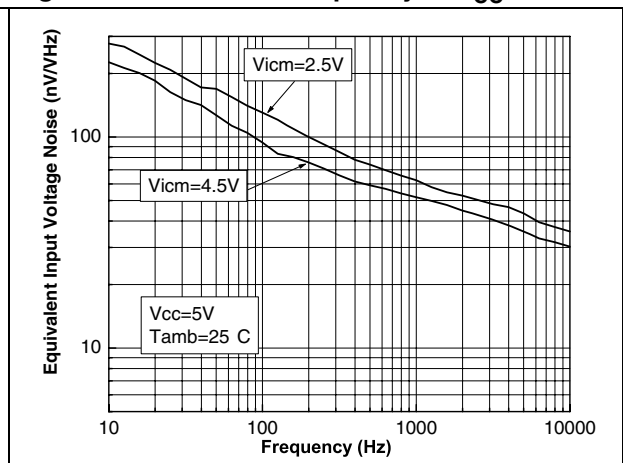

Figure 12. Noise vs. frequency at V_{CC} = 5 V



3 Application information

3.1 Operating voltages

The TSV6390 and TSV6391 can operate from 1.5 to 5.5 V. Their parameters are fully specified for 1.8, 3.3 and 5 V power supplies. However, the parameters are very stable in the full V_{CC} range and several characterization curves show the TSV639x characteristics at 1.5 V. Additionally, the main specifications are guaranteed in extended temperature ranges from -40°C to $+125^{\circ}\text{C}$.

3.2 Rail-to-rail input

The TSV6390 and TSV6391 are built with two complementary PMOS and NMOS input differential pairs. The devices have a rail-to-rail input, and the input common mode range is extended from $V_{CC-} - 0.1\text{ V}$ to $V_{CC+} + 0.1\text{ V}$. The transition between the two pairs appears at $V_{CC+} - 0.7\text{ V}$. In the transition region, the performance of CMRR, PSRR, V_{io} and THD is slightly degraded (as shown in [Figure 13](#) and [Figure 14](#) for V_{io} vs. V_{icm}).

Figure 13. Input offset voltage vs input common mode at $V_{CC} = 1.5\text{ V}$

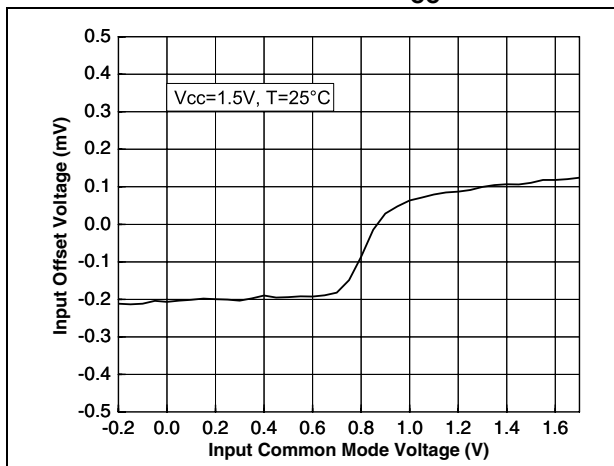
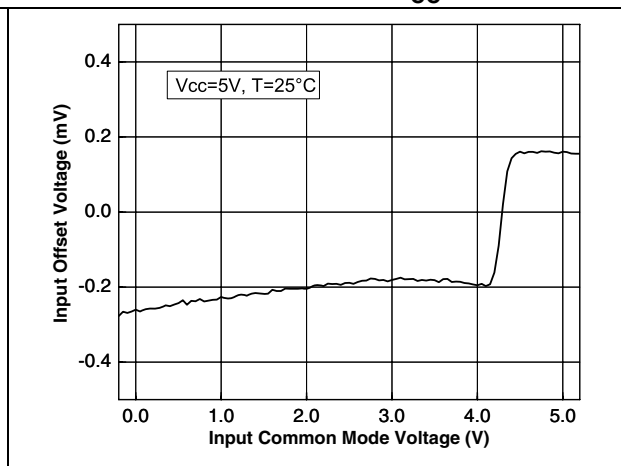

Figure 14. Input offset voltage vs input common mode at $V_{CC} = 5\text{ V}$



The devices are guaranteed without phase reversal.

3.3 Rail-to-rail output

The operational amplifiers' output levels can go close to the rails: 35 mV maximum above and below the rail when connected to a 10 kΩ resistive load to $V_{CC}/2$.

3.4 Shutdown function (TSV6390)

The operational amplifier is enabled when the $\overline{\text{SHDN}}$ pin is pulled high. To disable the amplifier, the $\overline{\text{SHDN}}$ must be pulled down to V_{CC-} . When in shutdown mode, the amplifier's output is in a high impedance state. The $\overline{\text{SHDN}}$ pin must never be left floating, but tied to V_{CC+} or V_{CC-} .

The turn-on and turn-off times are calculated for an output variation of ± 200 mV (Figure 15 and Figure 16 show the test configurations).

Figure 15. Test configuration for turn-on time (Vout pulled down)

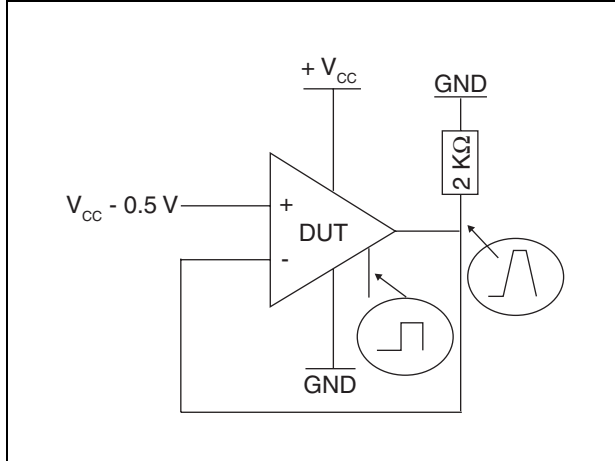

Figure 16. Test configuration for turn-off time (Vout pulled down)

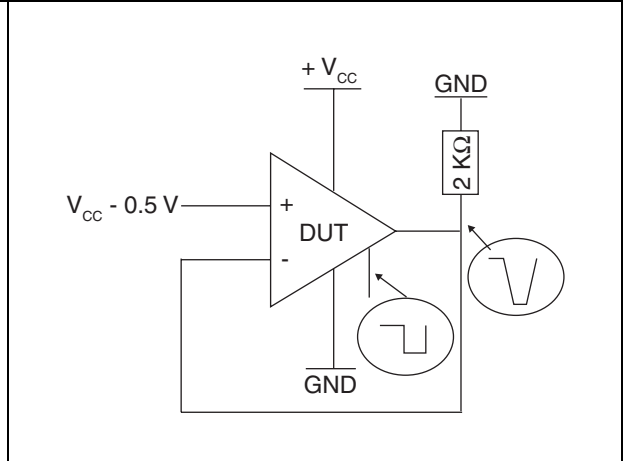

Figure 17. Turn-on time, $V_{CC} = 5$ V, V_{out} pulled down, $T = 25^\circ$ C

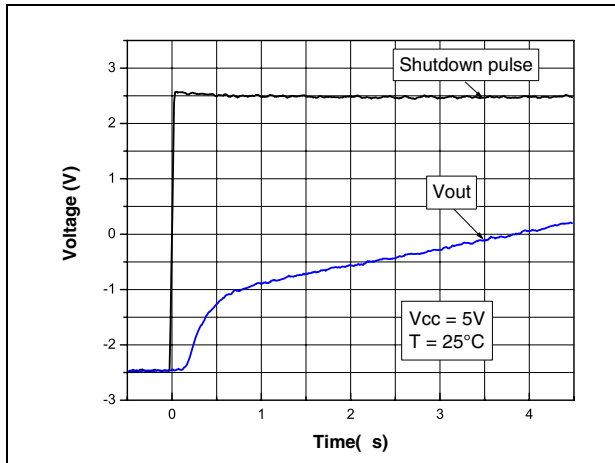
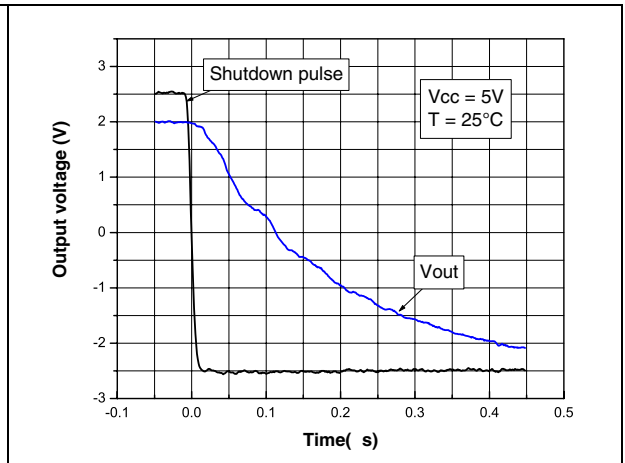

Figure 18. Turn-off time, $V_{CC} = 5$ V, V_{out} pulled down, $T = 25^\circ$ C



3.5 Optimization of DC and AC parameters

These devices use an innovative approach to reduce the spread of the main DC and AC parameters. An internal adjustment achieves a very narrow spread of the current consumption (60 μA typical, min/max at $\pm 17\%$). Parameters linked to the current consumption value, such as GBP, SR and A_{Vd} , benefit from this narrow dispersion.

3.6 Driving resistive and capacitive loads

These products are micropower, low-voltage operational amplifiers optimized to drive rather large resistive loads, above 2 k Ω . For lower resistive loads, the THD level may significantly increase.

These operational amplifiers have a relatively low internal compensation capacitor, making them very fast while consuming very little. They are ideal when used in a non-inverting configuration or in an inverting configuration in the following conditions.

- $|Gain| \geq 3$ in an inverting configuration ($C_L = 20$ pF, $R_L = 100$ k Ω) or $|gain| \geq 10$ ($C_L = 100$ pF, $R_L = 100$ k Ω)
- $Gain \geq +4$ in a non-inverting configuration ($C_L = 20$ pF, $R_L = 100$ k Ω) or $gain \geq +11$ ($C_L = 100$ pF, $R_L = 100$ k Ω)

As these operational amplifiers are not unity gain stable, for a low closed-loop gain it is recommended to use the TSV62x (29 μA , 420 kHz) or TSV63x (60 μA , 880 kHz) which are unity gain stable.

Table 8. Related products

Part #	I _{cc} (μA) at 5 V	GBP (MHz)	SR (V/ μs)	Minimum gain for stability (C _{Load} = 100 pF)
TSV620-1	29	0.42	0.14	1
TSV6290-1	29	1.3	0.5	+11
TSV630-1	60	0.88	0.34	1
<i>TSV6390-1</i>	<i>60</i>	<i>2.4</i>	<i>1.1</i>	<i>+11</i>

3.7 PCB layouts

For correct operation, it is advised to add 10 nF decoupling capacitors as close as possible to the power supply pins.

3.8 Macromodel

An accurate macromodel of the TSV6390 and TSV6391 is available on STMicroelectronics' web site at www.st.com. This model is a trade-off between accuracy and complexity (that is, time simulation) of the TSV639x operational amplifiers. It emulates the nominal performances of a typical device within the specified operating conditions mentioned in the datasheet. It also helps to validate a design approach and to select the right operational amplifier, *but it does not replace on-board measurements*.

4 Package information

In order to meet environmental requirements, ST offers these devices in different grades of ECOPACK[®] packages, depending on their level of environmental compliance. ECOPACK[®] specifications, grade definitions and product status are available at: www.st.com. ECOPACK[®] is an ST trademark.

4.1 SOT23-5 package mechanical data

Figure 19. SOT23-5L package mechanical drawing

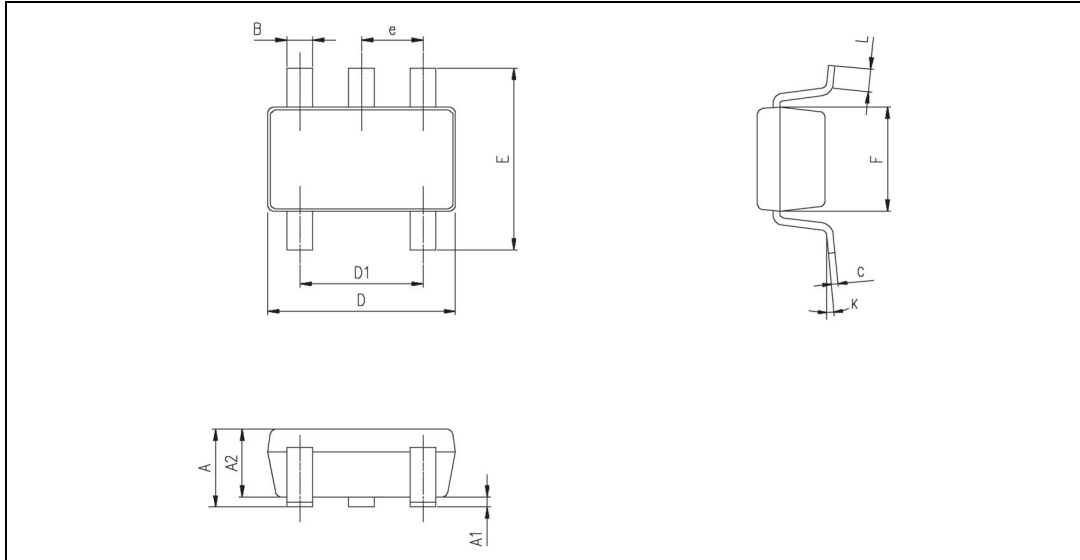

Table 9. SOT23-5L package mechanical data

Ref.	Dimensions					
	Millimeters			Inches		
	Min.	Typ.	Max.	Min.	Typ.	Max.
A	0.90	1.20	1.45	0.035	0.047	0.057
A1			0.15			0.006
A2	0.90	1.05	1.30	0.035	0.041	0.051
B	0.35	0.40	0.50	0.013	0.015	0.019
C	0.09	0.15	0.20	0.003	0.006	0.008
D	2.80	2.90	3.00	0.110	0.114	0.118
D1		1.90			0.075	
e		0.95			0.037	
E	2.60	2.80	3.00	0.102	0.110	0.118
F	1.50	1.60	1.75	0.059	0.063	0.069
L	0.10	0.35	0.60	0.004	0.013	0.023
K	0°		10°			

4.2 SOT23-6 package mechanical data

Figure 20. SOT23-6L package mechanical drawing

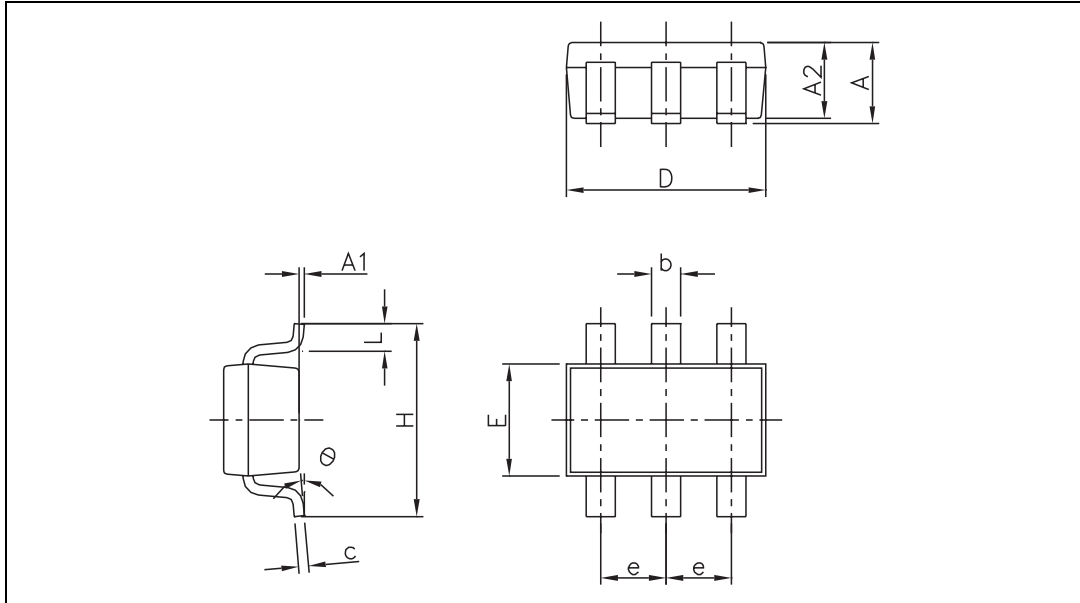

Table 10. SOT23-6L package mechanical data

Ref.	Dimensions					
	Millimeters			Inches		
	Min.	Typ.	Max.	Min.	Typ.	Max.
A	0.90		1.45	0.035		0.057
A1			0.10			0.004
A2	0.90		1.30	0.035		0.051
b	0.35		0.50	0.013		0.019
c	0.09		0.20	0.003		0.008
D	2.80		3.05	0.110		0.120
E	1.50		1.75	0.060		0.069
e		0.95			0.037	
H	2.60		3.00	0.102		0.118
L	0.10		0.60	0.004		0.024
°	0		10°			

4.3 SC70-5 (or SOT323-5) package mechanical data

Figure 21. SC70-5 (or SOT323-5) package mechanical drawing

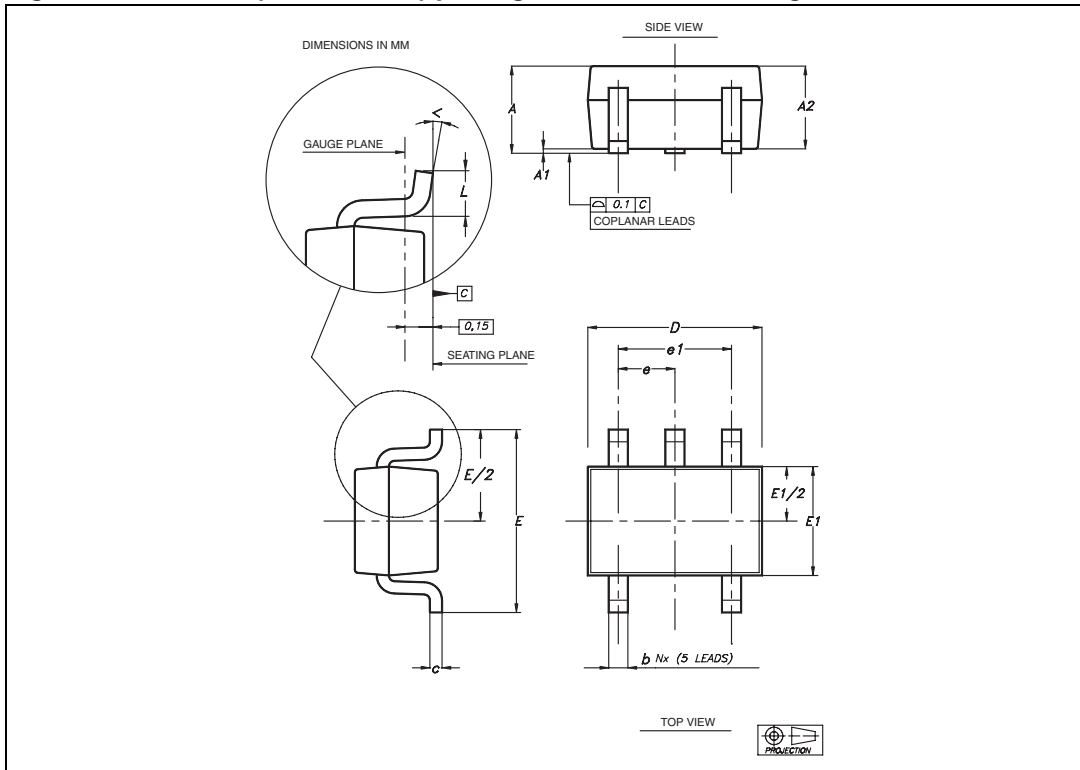

Table 11. SC70-5 (or SOT323-5) package mechanical data

Ref	Dimensions					
	Millimeters			Inches		
	Min	Typ	Max	Min	Typ	Max
A	0.80		1.10	0.315		0.043
A1			0.10			0.004
A2	0.80	0.90	1.00	0.315	0.035	0.039
b	0.15		0.30	0.006		0.012
c	0.10		0.22	0.004		0.009
D	1.80	2.00	2.20	0.071	0.079	0.087
E	1.80	2.10	2.40	0.071	0.083	0.094
E1	1.15	1.25	1.35	0.045	0.049	0.053
e		0.65			0.025	
e1		1.30			0.051	
L	0.26	0.36	0.46	0.010	0.014	0.018
<	0°		8°			

4.4 SC70-6 (or SOT323-6) package mechanical data

Figure 22. SC70-6 (or SOT323-6) package mechanical drawing

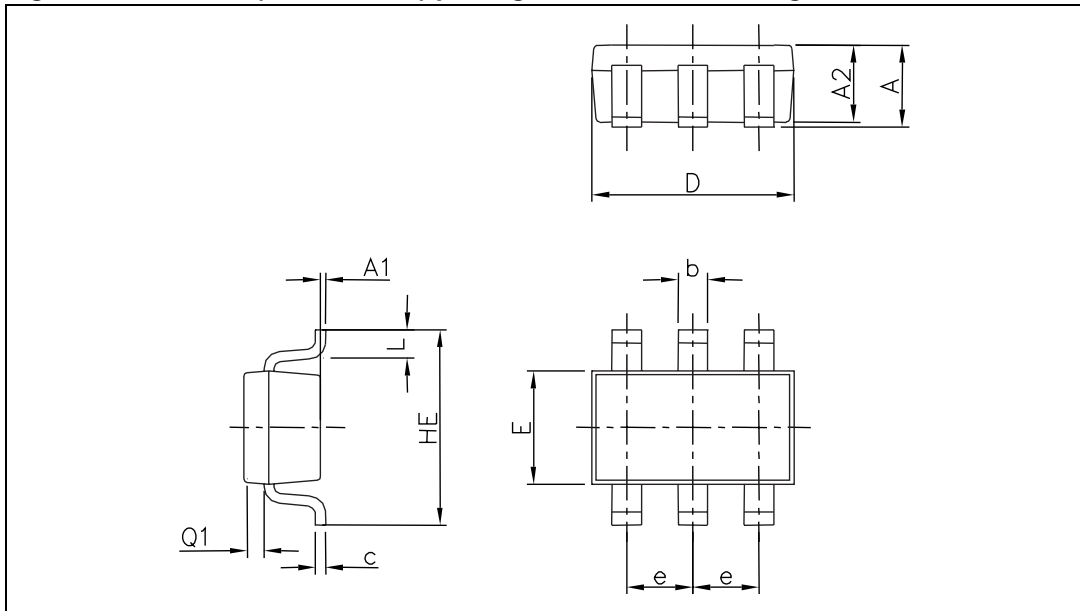
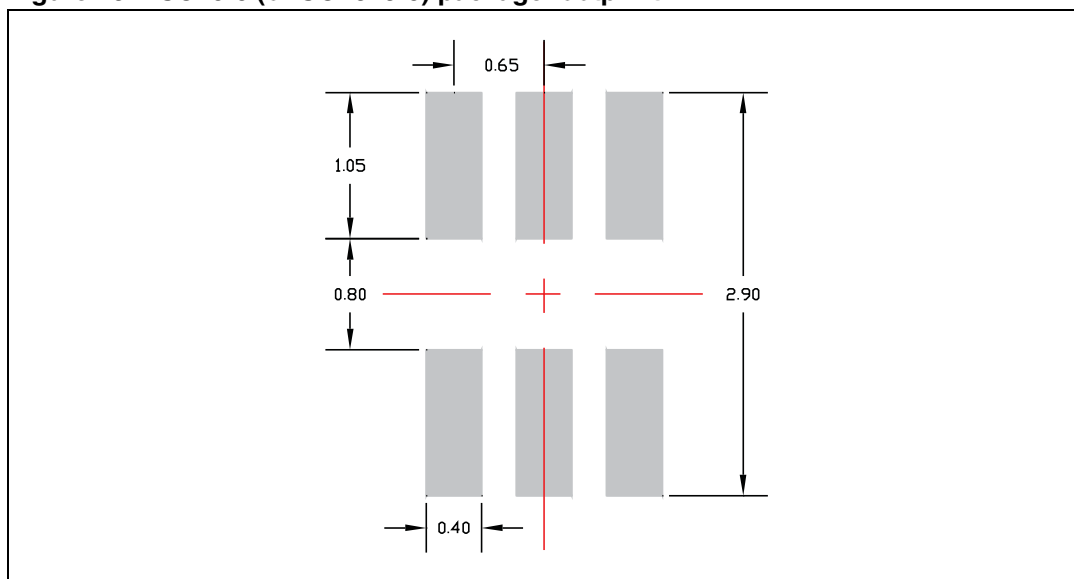

Table 12. SC70-6 (or SOT323-6) package mechanical data

Ref	Dimensions					
	Millimeters			Inches		
	Min.	Typ.	Max.	Min.	Typ.	Max.
A	0.80		1.10	0.031		0.043
A1			0.10			0.004
A2	0.80		1.00	0.031		0.039
b	0.15		0.30	0.006		0.012
c	0.10		0.18	0.004		0.007
D	1.80		2.20	0.071		0.086
E	1.15		1.35	0.045		0.053
e		0.65			0.026	
HE	1.80		2.40	0.071		0.094
L	0.10		0.40	0.004		0.016
Q1	0.10		0.40	0.004		0.016

Figure 23. SC70-6 (or SOT323-6) package footprint



5 Ordering information

Table 13. Order codes

Part number	Temperature range	Package	Packing	Marking
TSV6390ILT	-40°C to +125°C	SOT23-6	Tape & reel	K109
TSV6390ICT		SC70-6		K19
TSV6390AILT		SOT23-6		K142
TSV6390AICT		SC70-6		K42
TSV6391ILT		SOT23-5		K108
TSV6391ICT		SC70-5		K20
TSV6391AILT		SOT23-5		K141
TSV6391AICT		SC70-5		K41

6 Revision history

Table 14. Document revision history

Date	Revision	Changes
09-Mar-2010	1	Initial release.

Please Read Carefully:

Information in this document is provided solely in connection with ST products. STMicroelectronics NV and its subsidiaries ("ST") reserve the right to make changes, corrections, modifications or improvements, to this document, and the products and services described herein at any time, without notice.

All ST products are sold pursuant to ST's terms and conditions of sale.

Purchasers are solely responsible for the choice, selection and use of the ST products and services described herein, and ST assumes no liability whatsoever relating to the choice, selection or use of the ST products and services described herein.

No license, express or implied, by estoppel or otherwise, to any intellectual property rights is granted under this document. If any part of this document refers to any third party products or services it shall not be deemed a license grant by ST for the use of such third party products or services, or any intellectual property contained therein or considered as a warranty covering the use in any manner whatsoever of such third party products or services or any intellectual property contained therein.

UNLESS OTHERWISE SET FORTH IN ST'S TERMS AND CONDITIONS OF SALE ST DISCLAIMS ANY EXPRESS OR IMPLIED WARRANTY WITH RESPECT TO THE USE AND/OR SALE OF ST PRODUCTS INCLUDING WITHOUT LIMITATION IMPLIED WARRANTIES OF MERCHANTABILITY, FITNESS FOR A PARTICULAR PURPOSE (AND THEIR EQUIVALENTS UNDER THE LAWS OF ANY JURISDICTION), OR INFRINGEMENT OF ANY PATENT, COPYRIGHT OR OTHER INTELLECTUAL PROPERTY RIGHT.

UNLESS EXPRESSLY APPROVED IN WRITING BY AN AUTHORIZED ST REPRESENTATIVE, ST PRODUCTS ARE NOT RECOMMENDED, AUTHORIZED OR WARRANTED FOR USE IN MILITARY, AIR CRAFT, SPACE, LIFE SAVING, OR LIFE SUSTAINING APPLICATIONS, NOR IN PRODUCTS OR SYSTEMS WHERE FAILURE OR MALFUNCTION MAY RESULT IN PERSONAL INJURY, DEATH, OR SEVERE PROPERTY OR ENVIRONMENTAL DAMAGE. ST PRODUCTS WHICH ARE NOT SPECIFIED AS "AUTOMOTIVE GRADE" MAY ONLY BE USED IN AUTOMOTIVE APPLICATIONS AT USER'S OWN RISK.

Resale of ST products with provisions different from the statements and/or technical features set forth in this document shall immediately void any warranty granted by ST for the ST product or service described herein and shall not create or extend in any manner whatsoever, any liability of ST.

ST and the ST logo are trademarks or registered trademarks of ST in various countries.

Information in this document supersedes and replaces all information previously supplied.

The ST logo is a registered trademark of STMicroelectronics. All other names are the property of their respective owners.

© 2010 STMicroelectronics - All rights reserved

STMicroelectronics group of companies

Australia - Belgium - Brazil - Canada - China - Czech Republic - Finland - France - Germany - Hong Kong - India - Israel - Italy - Japan - Malaysia - Malta - Morocco - Philippines - Singapore - Spain - Sweden - Switzerland - United Kingdom - United States of America

www.st.com