



# WTC6208ASI 8 CHANNELS TOUCH SENSING BUTTON CHIP SPECIFICATION(V1.8)

1	Product Introduction .....	3
1.1	Brief Introduction .....	3
1.2	Technology .....	3
1.3	Sensibility Adjustment.....	4
1.4	Csel Value and Pannel Thickness .....	4
1.5	The Package Of WTC6208ASI .....	4
2	Features and Parameters .....	4
2.1	Key Features .....	4
2.1.1	Simple application circuit and fewer external Components .....	4
2.1.2	High Stability .....	4
2.1.3	Compact Keyboard with small Space .....	5
2.1.4	Excellent Waterproof .....	5
2.1.5	Excellent Anti-electromagnetic Interference .....	5
2.1.6	Unique Wire Length Self-adjustable Technology .....	5
2.1.7	Satisfying the requirements of industrial application.....	6
2.2	Parameters .....	6
2.2.1	Operating Voltage .....	6
2.2.2	Level Of Output.....	6
2.2.3	Panel (Insulated Media) Thickness .....	6
2.2.4	Effective Response Time Of Touch .....	6
2.2.5	Operating Temperature .....	6
2.2.6	Storage Temperature .....	6
3	Min Applications.....	7
4	Pin Assignment .....	7
5	Output Output Indication .....	8
5.1	The timing sequence chart .....	8
5.2	The truth table of WTC6208ASI .....	9
6	Typical Application Circuit.....	9





**WTC6208ASI**

---

6.1	The Application Circuit .....	9
6.2	The Requirement Of External components.....	10
7	Sensibility Setting .....	10
7.1	Select A Suitable Csel.....	10
7.2	The area of sense element.....	11
8	Power Supply.....	11
8.1	Voltage Regulator .....	12
8.2	The Place Of Regulator And External Components .....	12
8.3	Grounding .....	12
8.4	The Value Of C2 .....	12
8.5	High Noise Condition .....	12
8.6	Power Filter .....	12
8.7	Use +5V Power Of The Main System .....	13
9	Sense Element (Cap. Sensor) Used For WTC6208ASI.....	13
9.1	The Shape Of Sense Element.....	13
9.2	The Area Of Sense Element.....	14
9.3	The Interface Must Be Gapless.....	14
9.4	The Elastic Connection Methods.....	14
10	Treatment of Vacant Sensor Channel.....	15
11	Packing and Outline Dimensional Drawing of WTC6208ASI.....	15
12	Annex.....	17
12.1	Appendix 1: Attentions of PCB Layout.....	17
12.2	Appendix 1: The Example Operating Program of 8051 and WTC6208ASI Interface .....	20





# WTC6208ASI 8 CHANNELS TOUCH SENSING BUTTON CHIP SPECIFICATION(V1.8)

## 1 Product Introduction

### 1.1 Brief Introduction

WTC6208ASI is the Touch Sensing integrated circuit designed to realize the human touch interface. It may substitute the mechanical key to achieve the operator interface with waterproof, dustproof, sealing, separation, solid and good-looking performances. One WTC6208ASI can provide 3-8 independent keys and the users can use them flexibly as per the actual requirements.

### 1.2 Technology

WTC6208ASI product applies 16-bit high-precision CDC (capacitor digital converter) to identify the touch movement of human fingers via the capacitance changes on the IC detecting sense element (capacitance sensor). The data outputted from CDC will be processed by the built-in RISC processor with highly efficient and reliable algorithm, then BCD code output from the ports of WTC6208ASI to indicate the key status .

The internal block diagram of WTC6208ASI is shown as below:

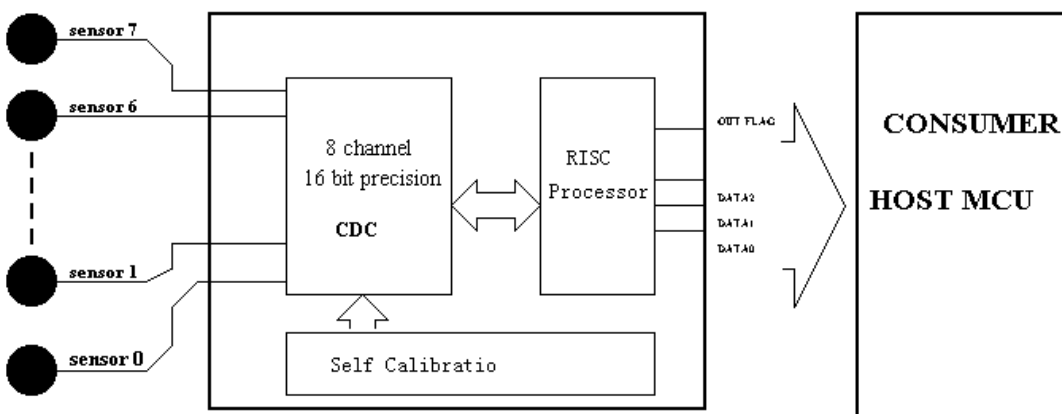



## WTC6208ASI

---

图 1: internal figure 1:block diagram of WTC6208ASI

### 1.3 Sensibility Adjustment

The sensibility of all channels may be adjusted by one capacitor Csel.

### 1.4 Csel Value and Pannel Thickness

By adjusting the capacitance value of Csel and the area of sense element properly, WTC6208ASI can apply to the insulation panels with different thickness spanning from 0 to 20mm.

### 1.5 The Package Of WTC6208ASI

The WTC6208ASI is packaged with the standard 16PIN NSOP (150mil).

## 2 Features and Parameters

### 2.1 Key Features

#### 2.1.1 Simple application circuit and fewer external Components

WTC6208ASI is built in dedicated metrical circuit, self-calibration circuit and RISC processor, designed by Wincom Technology independently, with fewer external components.

#### 2.1.2 High Stability

Production commissioning-free and excellent long-term operation stability

It's unnecessary to calibrate the system after the sensibility is determined after the capacitor Csel value is pre-set. The system can automatically overcome the disturbances caused by the electrostatic discharge, electromagnetic interference, temperature variation, humidity and





## WTC6208ASI

---

pollutants piled on the surface, so as to provide sound precision and operation consistency in various environments. It may be transported for a long distance and used in various conditions. The unique compensation algorithm and high-intensity anti-interference design can ensure the product free from accidental operation in case of long-term operation.

### 2.1.3 Compact Keyboard with small Space

The users can use the compact keyboard with small spaces. The adjacent key suppression function can prevent the accidental operation of adjacent keys. The users can use the compact keyboard with fewer spaces (space less than 2mm).

### 2.1.4 Excellent Waterproof

It's designed with special waterproof feature. The WTC6208ASI can not only resist splash and water overflow, but also can be used normally after being flooded, different with the general products of other company sold on the market at present, those may be operated accidentally upon water splash and overflow and operate slowly after waterlogging, or may be operated accidentally after being pressed by fingers.

### 2.1.5 Excellent Anti-electromagnetic Interference

It may be used for the home appliance and products applied in general application conditions. The products can be good anti- RF signal interference performance even use the one layer PCBs, it can resist the interference of most RF interference source upon the IC, including GSM cell phones. Upon application for military purpose and other special case, it's recommended to use the two layers PCBs and design it as per the layout requirement offered by this datasheet.

### 2.1.6 Unique Wire Length Self-adjustable Technology

The identical products sold on the market at present are involved with the problems of great discrepancy of induction sensibility as the connection line from the sense element to IC pin varies. While the line length self-adjustable feature innovated by us may automatically correct the discrepancy. The users can obtain the almost consistent sensibility of all keys on the whole sense panel, without bothering with complicated adjustment.





### **2.1.7 Satisfying the requirements of industrial application**

The product can provide more reliable performances, more expansive application scope for the users.

## **2.2 Parameters**

### **2.2.1 Operating Voltage**

Single power  $3.3 < V_{cc} < 5.5V$

### **2.2.2 Level Of Output**

$GND < V_{out} < V_{cc}$

### **2.2.3 Panel (Insulated Media) Thickness**

0-20mm

### **2.2.4 Effective Response Time Of Touch**

: less than 150ms

### **2.2.5 Operating Temperature**

$-40^{\circ}C \sim +85^{\circ}C$

### **2.2.6 Storage Temperature**

$-50^{\circ}C \sim +125^{\circ}C$





WTC6208ASI

### 3 Min Applications

The product applies to various kitchen appliances, media players, air conditioners, sanitary electric appliances, lighting switches, security, instrument and meters, game pads, mobile phones, sport machines , educational machines, etc.

### 4 Pin Assignment

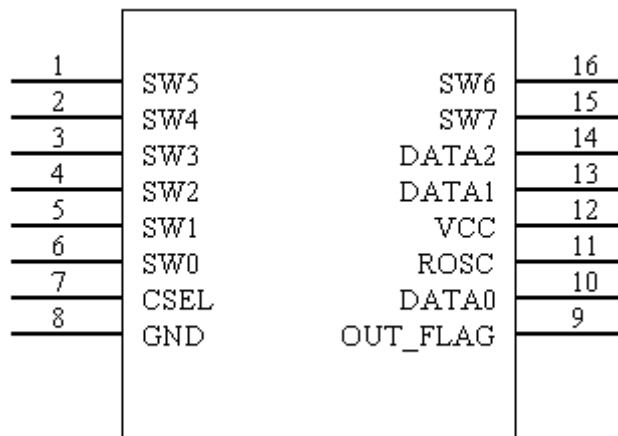

Figure 2: Figure of WTC6208ASI Pin assignment

Table 1: WTC6208ASI Pin Assignment

Pin Number	Pin Name	Usage	Function Description
1	SW5	I	Button(Sense Element)5 input
2	SW4	I	Button(Sense Element)4 input
3	SW3	I	Button(Sense Element)3 input
4	SW2	I	Button(Sense Element)2 input
5	SW1	I	Button(Sense Element)1 input
6	SW0	I	Button(Sense Element)0 input
7	CSEL	I	Sensibility Setting Capacitor Port
8	GND	I	Power GND
9	OUT_FLAG	O	Button Status Indication , effective touch is "0" , no





WTC6208ASI

			effective touch is "1"
10	DATA0	O	BCD Code DATA0 OUTPUT
11	ROSC	I	10K pull-up resistor
12	VCC	I	Power input
13	DATA1	O	BCD Code DATA1 output
14	DATA2	O	BCD Code DATA2 output
15	SW7	I	Button(Sense Element)6 input
16	SW6	I	Button(Sense Element)6 input

## 5 Output Output Indication

### 5.1 The timing sequence chart

When WTC6208ASI judges that any button( sense elements) is touched, it will output a low level signal within 100 ms from OUT\_ FLAG pin, and the BCD code of touched button will be output from DATA0,DATA1,DATA2 in the same time, HOST MCU can read the BCD code of touched button when OUT\_ FLAG signal is low.

Note: OUT\_FLAG serves as flag of any key is touched, instead of indicating the time of key is touched. The signal of OUT\_FLAG and the BCD code of touched key will be retained till the finger leaves it, we can just read the BCD code while the OUT\_FLAG signal is low .The reading program shall be query mode.

The timing sequence chart of WTC6208ASI show as below:

The initializing level of output is high

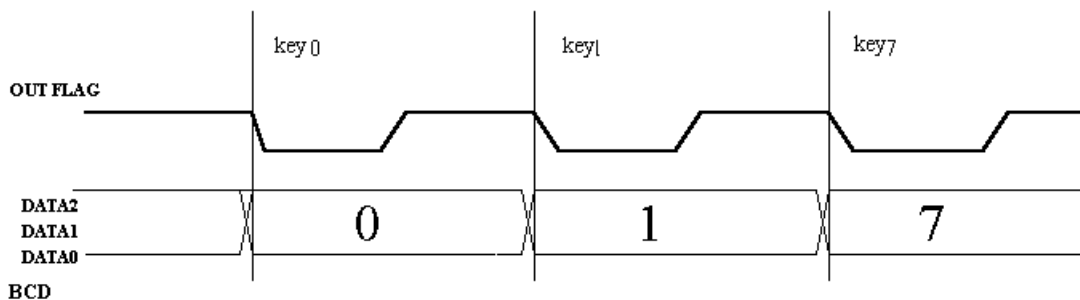

Figure 3 : The timing sequence chart of WTC6208ASI







WTC6208ASI

5.2 The truth table of WTC6208ASI

Output Input		OUT_FLAG	BCD code		
			DATA0	DATA1	DATA2
	Initial	H	H	H	H
SW0	Touch	L	L	L	L
	Leave	H	---	---	---
SW1	Touch	L	H	L	L
	Leave	H	---	---	---
SW2	Touch	L	L	H	L
	Leave	H	---	---	---
SW3	Touch	L	H	H	L
	Leave	H	---	---	---
SW4	Touch	L	L	L	H
	Leave	H	---	---	---
SW5	Touch	L	H	L	H
	Leave	H	---	---	---
SW6	Touch	L	L	H	H
	Leave	H	---	---	---
SW7	Touch	L	H	H	H
	Leave	H	---	---	---

6 Typical Application Circuit

6.1 The Application Circuit

The application schematic of WTC6208ASI is very simple, with only several resistance and capacitance parts. The key components are Csel and 1K resistor group.

The application circuit of WTC6208ASI operating in normal mechanical button mode is shown as below





### WTC6208ASI

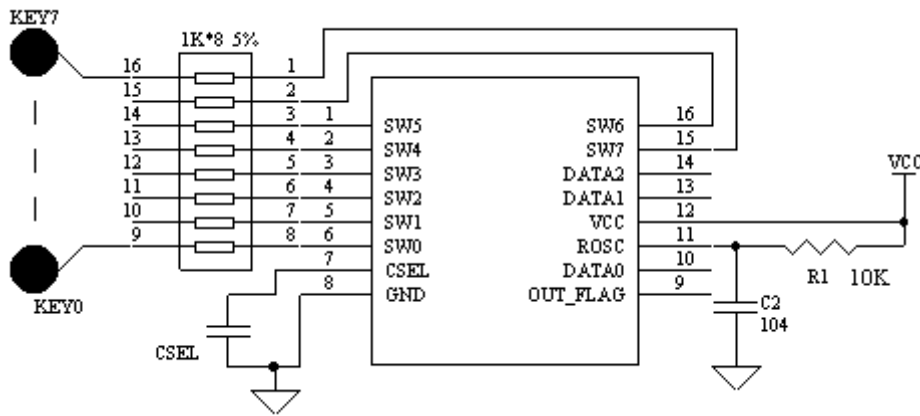

Figure 4: Application Circuit of WTC6208ASI

RP1 and RP2 are the matching resistors, please make sure to put them closer to IC.

CSEL are the 10% dacron capacitor 0.0047UF- 0.022UF or 10% X7R capacitor 0.0047UF- 0.022UF

## 6.2 The Requirement Of External components

Csel is sensibility adjusting capacitor, It's required to use the terylene capacitor, **X7R material surface mount** capacitor or **NPO material surface mount** capacitor with the precision of 10% or above for CSEL. 1K resistor groups are for impedance matching of each cap. sensor channel. 1K resistance group may provide the best and most stable measurement effect for WTC6208ASI. Note: **Please make sure to put CSEL and matching resistor closer to IC as much as possible when PCB layout.**

## 7 Sensibility Setting

With the sensibility setting of WTC6208ASI, the users can use the spacer media with various thicknesses for reliable and flexible touch functions.

The sensibility setting of WTC6208ASI is done by selecting CSEL value.

### 7.1 Select A Suitable Csel

Firstly, the users shall select the suitable capacitor Csel pursuant to their actual application. The thicker is the spacer media and the bigger is the capacity of Csel, the higher is the sensibility. Generally it's recommended to select the suitable capacitors between 0.0047UF and 0.022UF, from down to up. It's recommended to apply terylene





### WTC6208ASI

capacitor with the precision of 5% with small temperature coefficient for Csel, or the terylene capacitor with the precision of 10%. If surface mounted capacitors are used, please select X7R material surface mount capacitor or NPO material surface mount capacitor with the precision of 10% or above for CSEL.

## 7.2 The area of sense element

Increasing the area of sense element may help to improve the penetrating ability of touch sense.

## 8 Power Supply

WTC6208ASI is used to measure the tiny change of capacitance, requiring small ripples and noise of power supply, free from the external strong disturbance of power supply penetration, especially when it's applied to induction cooker and microwave furnace, the external interference and abrupt change of voltage should be effectively separated. So the power supply is required with higher stability. It's recommended to apply the stabilized pressure line composed of 78L05 as shown below.

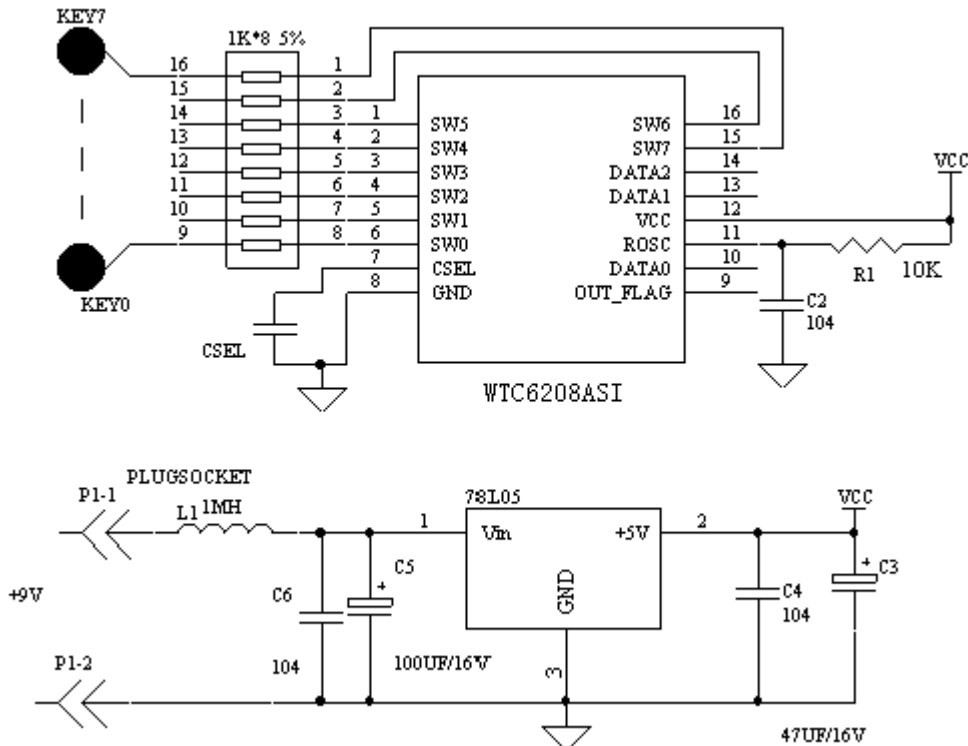



## WTC6208ASI

Figure 7: The Simple Operation Circuit With Voltage Regulator

### 8.1 Voltage Regulator

When PCB LAYOUT, the components of 78L05 power package must be put close to VCC pins of WTC6208ASI.

### 8.2 The Place Of Regulator And External Components

78L05, peripheral components and WTC104BLSI must be set on the same circuit board collectively, to avoid much noise caused by the extra long power supply line.

### 8.3 Grounding

The common grounds of components shown in the above figure must be separately connected into an independent group and then connect a separate point to the common ground of whole unit. (The astral one-point grounding shall be applied.) ,

### 8.4 The Value Of C2

C2 capacity would impact the discharge time after power fail, higher capacity requires longer reset time. The values in circles are the recommended values, the users can adjust the values as per the different application purposes.

### 8.5 High Noise Condition

When the product is applied in the environment with high noise, just avoid to stack the main board with high voltage (220V), large current and high frequency operation and the touch circuit boards. When it's inevitable, just put them far away from the components with high voltage and large current or add shielding device on the main board.

### 8.6 Power Filter

Upon PCB typesetting, it's recommended to reserve inductive L1(1MH) bonding pad, which may be not needed in some special applications. Input the power supply of 78L05, pay attention to the ripples and make sure the wave hollow of ripples not lower than DC 8V.



## 8.7 Use +5V Power Of The Main System

If the power supply of touch panel is from main system, just add power filter circuit before the VCC of WTC6208ASI. The requirements for PCB layout are the same with those for the foregoing circuit.

The power filter Circuit show in the following figure

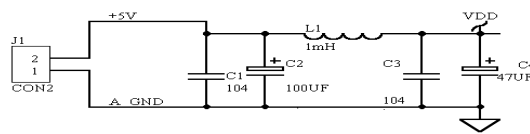

Figure 8: Power Supply Filter Circuit

The power supplies of analog and digital sections of circuit shall be separately connected with astral connection method and the sequence of capacitors shall be arranged as per that shown in the schematic diagram and shall not be arranged randomly.

### Note:

This circuit bears sound capacity restricting the power noise, but it is apt to generate self-excitation when it's connected to higher load. It's recommended that the users shall not connect other loads than touch module or touch chip set. The loads like relays and other ICs shall be connected before this circuit, with other filter voltage regulator added to it.

## 9 Sense Element (Cap. Sensor) Used For WTC6208ASI

### 9.1 The Shape Of Sense Element

The sense element (cap. sensor) may be the conductor in any shapes, but it shall bear some planar area. It's recommended to use the round sheet metal or other conductors whose diameter is above 3mm×3mm. The sense elements usually used include copper foil on PCB, spring, membrane circuit and ITO glass, etc...



Figure 9: PCB Copper Foil Sense Element

The sense elements may be solid or hollow rectangles, roundness or polygon.

## 9.2 The Area Of Sense Element

Make sure to keep the area of every sense element the same as much as possible to ensure the consistent sensibility.

## 9.3 The Interface Must Be Gapless

The air gap between the top surface of sense element and panel back surface will cause the sensibility decrease sharply, so the interface between them must be jointed closely, make sure no gap between them. The surfaces of sense elements shall be flat, free from any clearance with the panel.

## 9.4 The Elastic Connection Methods

Commonly used include

- A To use the sense elements with springs
- B To make the elastic connection with cylindrical conductive rubber
- C Affix the sense elements with imported high tenacity double sticky tape onto the panel and the double sticky tape shall be not too thick.



Figure 10: Spring Sense Element

## 10 Treatment of Vacant Sensor Channel

It's required to use at least 3 touch keys for WTC6208ASI, otherwise, the modules would not operate normally. When applied in the occasions less than 8 keys, there would be unoccupied sensor input channels among SW0-SW7. The vacant input channels cannot be suspended, just combine the vacant input channels together and then connect them with a 1K pull high resistor connect to VCC of WTC6208ASI.

## 11 Packing and Outline Dimensional Drawing of WTC6208ASI

SYMBOLS	DIMENSIONS LIMETER		
	MIN	NOM	MAX
A	1.35	1.60	1.75
A1	0.10	—	0.25
A2	—	1.45	—
B	0.33	—	0.51
C	0.19	—	0.25
D	9.80	—	10.00
E	3.80	—	4.00



WTC6208ASI

c	—	1.27	—
H	5.80	—	6.20
L	0.40	—	1.27
$\theta$	0.00	—	8.00

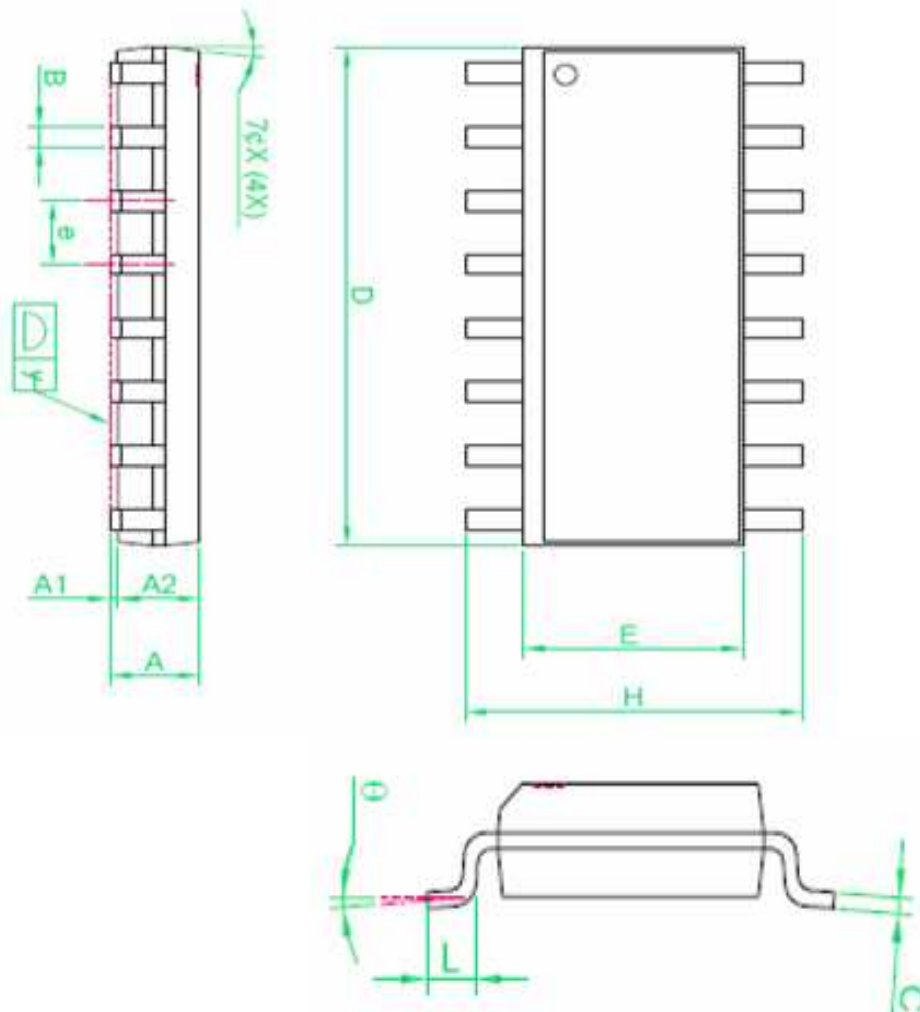

Figure10 : WTC6208ASI Outline Dimensions







## 12 Annex

### 12.1 Appendix 1: Attentions of PCB Layout

- 1: Use WTC series of touch chips. Upon PCB layout, please put 1K measurement matching resistance group and sensibility adjusting capacitors of Csel close to IC as much as possible.
- 2: Upon PCB layout, please make sure the basic balanced distance from the touch chip to the sense element, shown as below:

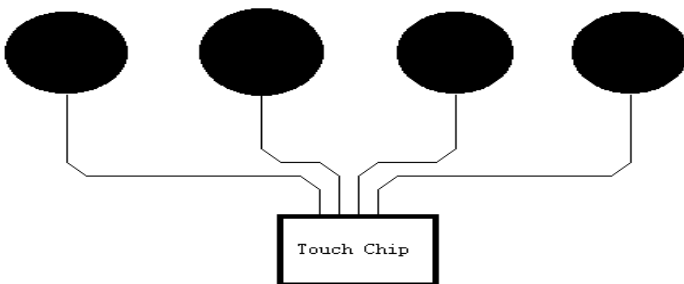

Figure 13: Rational PCB Layout

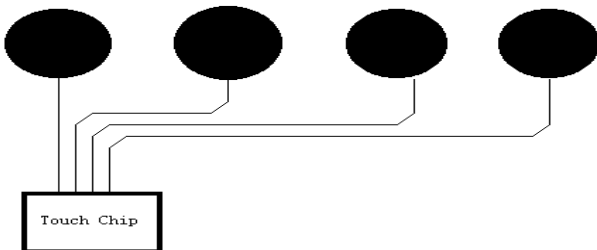

Figure 14: Irrational PCB Layout

- 3: The connection line between the sense element and touch chip shall be as thin and short as possible. It's recommended to apply 5 mil line width as much as possible if it's allowed by PCB technique.
- 4: The connection line between the sense element and touch chip shall not span over the signal wire with high distance and high frequency.
- 5: No other signal wires shall be connected within 0.5mm scope of the connection line between the sense element and touch chip.
- 6: If the users apply the copper foil patterns on the PCB directly as the touch sense element, they shall use the two layers PCBs. The connection line between the touch chip, sense element and IC pins shall be put on the back of sense element copper foil (BOTTOM). The sense element shall be put close to the touch panel.
- 7: The copper laid on the copper surface of sense element shall be done with grid patterns and the area of copper in the grids shall not exceed 40% of the total area of copper in grids. Copper shall be laid with more than 0.5mm distance from the sense element and touch chip. In principle, if copper is laid on the back of connection line between the sense element and IC, just apply the patterns in the way as shown in Figure 15, and the copper area shall not exceed 40% of the total area of copper in grids.



40%

Figure 15: Copper Pattern on the Surface of Sense Element



Top of PCB

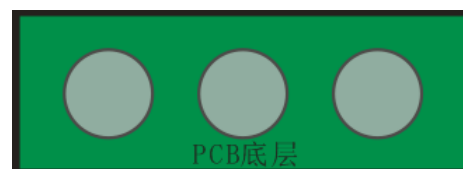

Bottom of PCB

Figure 16: Grid copper shall be laid outside the key sense element on top of PCB

Figure 17: Grid copper shall not be laid underneath the key sense element at the bottom of PCB

- 8: Copper to be laid on the back of sense element copper (BOTTOM) shall apply the solid copper sheet. But Copper shall be laid with more than 0.5mm distance from the sense element and touch chip. The back directly opposite to the sense element shall be not be laid with copper, any large-area copper foil and other signal wires are not allowed on the back directly opposite to the sense element.

- 9: Apply the connection method for the hole connection between the connection line and sense element shown in

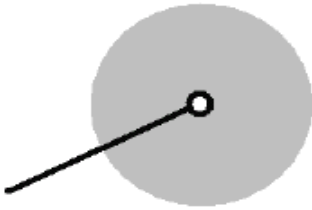

Figure 17.

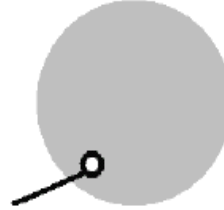

Figure 18: Poor Connection

Figure 19: Sound Connection

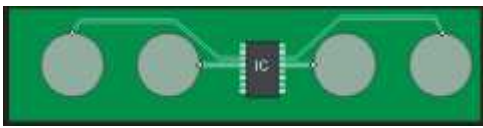

Figure 20: Sound Wiring Method

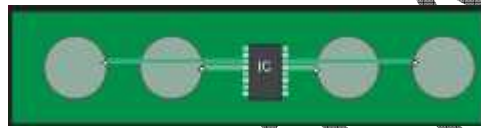

Figure 21: Poor Wiring Method

10:

PCB LAYOUT Example:

The copper foil of sense element shall be painted with green oil so that copper is not exposed.

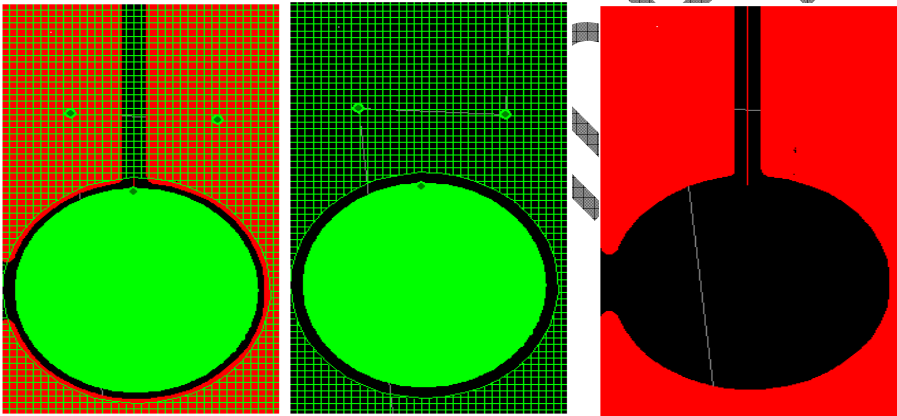
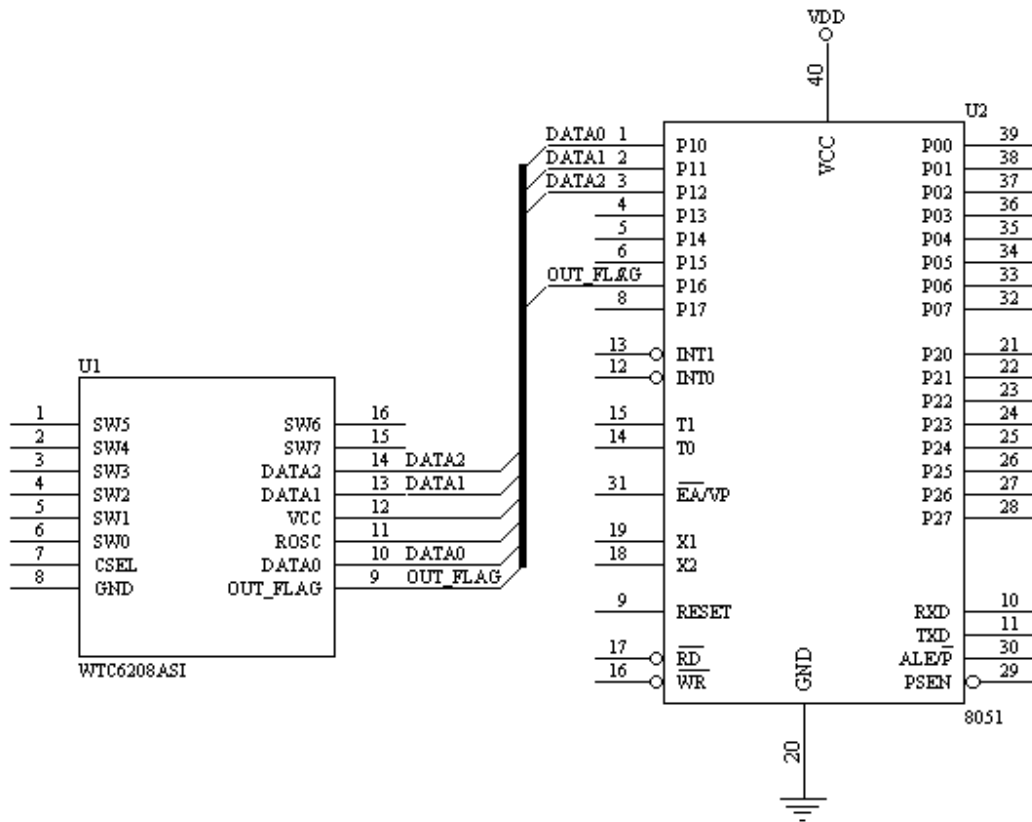

Figure 22: Example



## 12.2 Appendix 1: The Example Operating Program of 8051 and WTC6208ASI Interface

The function of example realized by this example procedure is to make 8051 to read the code of touched button of BCD bus of touch sensing chip, and to display with LED. Each LED would display the status of corresponding keys.



### The Example Operating Program of 8051 and WTC6208ASI Interface

```
#include <reg51.h>
#define uchar unsigned char
```





WTC6208ASI

```
#define      uint      unsigned int

//-----WTC6208ASI interface-----
#define      DaPort    P1
sbit      Out_Flag =    P1^6;
sbit      OUT_DA2   =   P1^2;
sbit      OUT_DA1   =   P1^1;
sbit      OUT_DA0   =   P1^0;

//-----LED display interface-----
sbit      LED7      =   P0^7;
sbit      LED6      =   P0^6;
sbit      LED5      =   P0^5;
sbit      LED4      =   P0^4;
sbit      LED3      =   P0^3;
sbit      LED2      =   P0^2;
sbit      LED1      =   P0^1;
sbit      LED0      =   P0^0;

//-----function-----
void      delay_loop(uchar i);      //delay function
void      led_on(uchar LedControler); // LED on
void      led_off(uchar LedControler); //LED off

//-----variable definition -----
uchar      GetKey;      //WTC6208ASI output BCD code
uchar      temp;      //middle variable

//-----
//
//-----

void main(void)
{
    while(1)
    {
        DaPort = 0xff;
        if(~Out_Flag)
        {
            //the indicating LED on when the button is touched
            GetKey = DaPort;
            GetKey &= 0x07;
        }
    }
}
```





```
        led_on(GetKey);
    }
    else
    {
        // the indicating LED off after finger left the button
        led_off(GetKey);
    }
}
}

//-----
void delay_loop(uchar i)
{
    while(i)
    {
        i--;
    }
}

//-----
void led_on(uchar LedControler)
{
    switch(LedControler)
    {
        case 0: LED0 = 0; break;
        case 1: LED1 = 0; break;
        case 2: LED2 = 0; break;
        case 3: LED3 = 0; break;
        case 4: LED4 = 0; break;
        case 5: LED5 = 0; break;
        case 6: LED6 = 0; break;
        case 7: LED7 = 0; break;
    }
}

//-----
void led_off(uchar LedControler)
{
    switch(LedControler)
    {
```





A Professional Touch Sensing Chip Supplier

<http://www.wincomtech.com>

WTC6208ASI

```
case 0: LED0 = 1; break;
case 1: LED1 = 1; break;
case 2: LED2 = 1; break;
case 3: LED3 = 1; break;
case 4: LED4 = 1; break;
case 5: LED5 = 1; break;
case 6: LED6 = 1; break;
case 7: LED7 = 1; break;
}
}
```

**Address of Shenzhen office:**

FLAT/RM. 12H, HAIXIA GE, HAIZHU CHENG CHUANG YE ROAD, NANSHAN  
DISTRICT, SHENZHEN, CHINA POST CODE: 518054

TEL: 86-755-26406919 13392806258

FAX: 86-755-26403148

[martin@wincomtech.com](mailto:martin@wincomtech.com), [szmartiny@yahoo.com.cn](mailto:szmartiny@yahoo.com.cn)

**HONGKONG ADD.:** FLAT RM M 4/F CONTINENTAL MANSION 300KING'S ROAD, HK.

TEL: (852) 6949328

CONFIDENTIAL

*End of Specification*

*Thanks!!*





**A Professional Touch Sensing Chip Supplier**

<http://www.wincomtech.com>

WTC6208ASI

---

CONFIDENTIAL

