

1

2

3

4

5

6

7

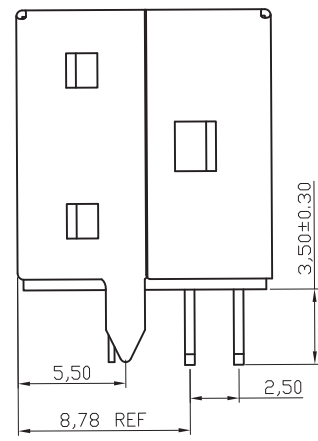
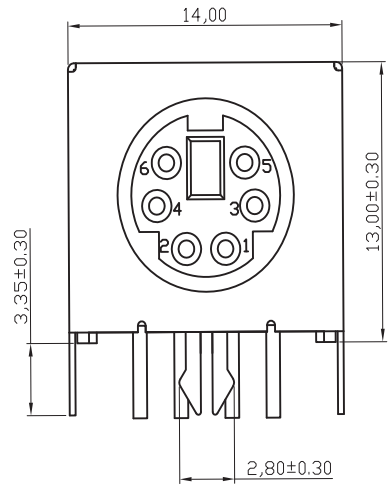

- 1.Material:
 Contacts :Brass
 Insulator:PBT+30%G.F UL94V-0
 Shell : Brass
- 2.Mechanical:
 Mating Force:45N max.
 Withdrawal Force:7N min.
 Durability:500 cycles min.
- 3.Electrical:
 Current-max[amps] 1.0A
 Voltage-max[volts] 30V
 Withstanding Voltage 750V AC
 Contact Resistance [ohms] 30 milliohms max
 Insulation Resistance [ohms] 1000 Megohms min
- 4.Plating:
 Contacts: Gold Flash Selective over Nickel
 Shell:Nickel
- 5.Environmental
 Temperature Range -55°C~+85°C

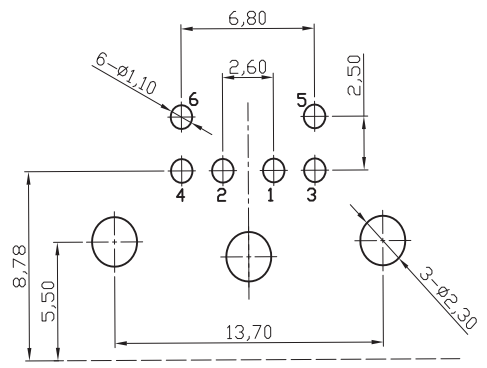
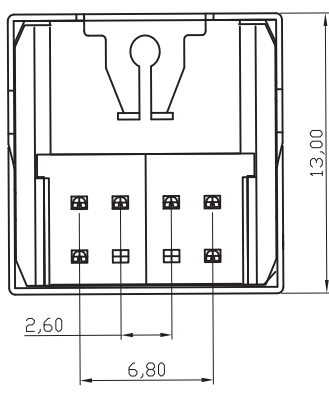

RECOMMENDED P.C.B. PATTERN LAYOUT
 TOP VIEW (TOLERANCE: ±0,05)

ASSMANN WSW P/N	HOUSING COLOR
A-DIO-FS06/GREEN	GREEN

RoHS compliant

Scale	1:1					Date	Name	
TOLERANCE						Drawn	15.07.2009	Rale
X.X	±0.38					Approved	25.11.2010	Gerber
X.XX	±0.25							
X.XXX	±0.15							
DIM	TOL	②	Change the manufacture plant	25.11.2010	Alex			
X.°	±1°							
X.X°	±X°	①	Drawn	15.07.2009	Rale			
Angle	TOL	Id.	Modification	Date	Name			

Customer-No.	
ASSMANN WSW-No. A-DIO-FS06/GREEN	
Drawing-No.	ASS 3567 CO
Replace	rev02
	Sheet

1

2

3

4

5

6

7