



---

A High Precision, Low Cost, Single Supply ADC for  
Positive and Negative Input Voltages

---

## Introduction

In general the ADC embedded in the ST7 microcontroller is enough for most applications. But, in some cases it is necessary to measure both positive and negative voltages. This requires an external ADC with this particular capability. Most external ADCs require a dual supply to be able to do this. However, microcontroller-based applications usually only have a positive supply available.

This application note describes a technique for implementing an ADC for measuring both positive and negative input voltages while operating from a single (positive) supply. This converter is based on a **Voltage-to-time Conversion** technique. Like other slope converters, this ADC also uses an **Integrating Capacitor**, but the measured time is inversely proportional to the input voltage. An additional comparator with a voltage reference is used to improve conversion accuracy.

As shown in the circuit diagram ([Figure 1](#)), the converter is implemented using an integrating capacitor, resistor, external op-amp, comparators and some I/O pins (the ST72F264 microcontroller is used in this example). The 16-bit timer of the microcontroller measures the time using its input capture pins (PB0 and PB2). These pins are connected to the output of the Comp1 and Comp2 comparators. The I/O pins PB1 and PB3 are used to switch the M1 and M2 switches ON or OFF. The circuit could also work with a microcontroller equipped with an 8-bit timer. Only a small modification to the software would be needed.

## Contents

<b>1</b>	<b>Circuit diagram</b> .....	<b>4</b>
<b>2</b>	<b>Theory of operation</b> .....	<b>5</b>
	2.1 Advantage of using two comparators .....	5
<b>3</b>	<b>Timing diagram</b> .....	<b>6</b>
<b>4</b>	<b>Circuit analysis</b> .....	<b>7</b>
<b>5</b>	<b>Vout vs time diagram for different input voltages</b> .....	<b>8</b>
<b>6</b>	<b>Characteristics of different slope converters</b> .....	<b>9</b>
	6.1 Single-slope converter .....	9
	6.1.1 Timing diagram .....	9
	6.2 Dual-slope converter .....	10
	6.2.1 Timing diagram .....	10
	6.3 Solution presented in this application note .....	10
<b>7</b>	<b>Error analysis / constraints</b> .....	<b>12</b>
	7.1 Input offset voltage .....	12
	7.2 Correction factor for the product of $R \cdot C$ .....	12
	7.3 Value of charging resistance $R$ .....	12
	7.4 Charging capacitor $C$ .....	12
	7.5 16-bit TIMER .....	13
	7.6 Effect of temperature .....	13
	7.7 Comparator .....	13
<b>8</b>	<b>Voltage references</b> .....	<b>14</b>
<b>9</b>	<b>Hardware setup</b> .....	<b>15</b>
<b>10</b>	<b>Algorithm</b> .....	<b>16</b>
<b>11</b>	<b>Result</b> .....	<b>17</b>

11.1	Positive input	17
11.2	Negative input	20
11.3	Effect of the capacitor value	22
<b>12</b>	<b>Conclusion</b>	<b>24</b>
<b>13</b>	<b>References and bibliography</b>	<b>25</b>
<b>Appendix A</b>	<b>Input stage conditions.</b>	<b>26</b>
A.1	Case 1: voltage measurement.	26
A.2	Case 2: Current measurement.	27
<b>Appendix B</b>	<b>Application board schematics</b>	<b>28</b>
<b>Appendix C</b>	<b>Bill of materials</b>	<b>29</b>
<b>Appendix D</b>	<b>Software flow</b>	<b>31</b>
D.1	Code size.	31

# 1 Circuit diagram

Figure 1. Circuit diagram

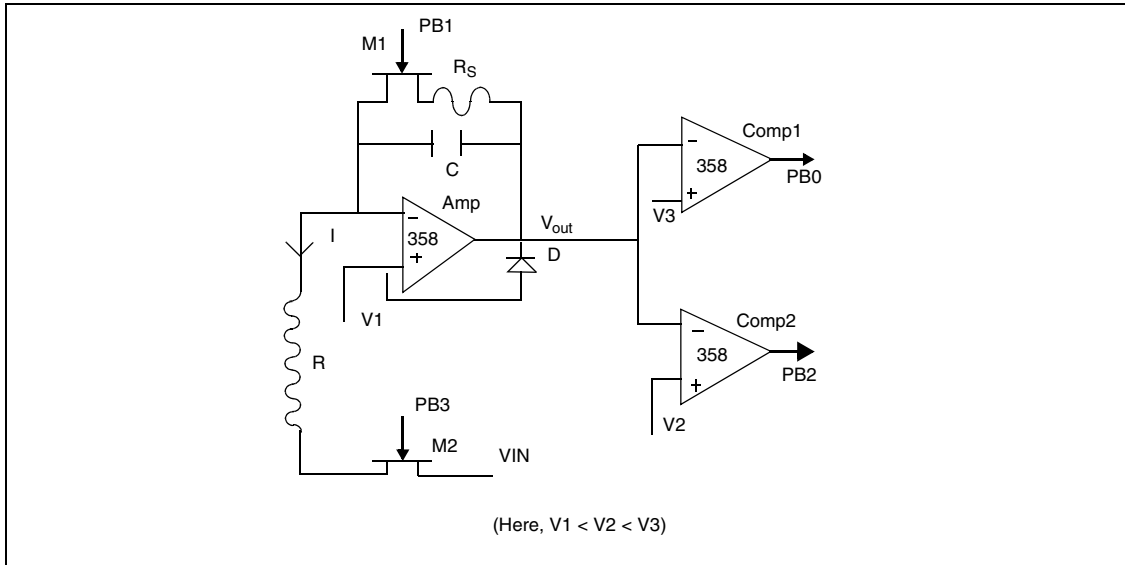

## 2 Theory of operation

$V_{in}$  is the Input voltage. The voltages across resistor R are the reference voltage  $V_1$  and the input voltage  $V_{in}$ . Due to the properties of the op-amp,  $V_1$  is output on the inverting pin of the op-amp. Therefore, for a given input voltage, the current flowing through resistor R will be constant. Let this current be I.

Current I charges the capacitor C, and output starts increasing in the positive direction for the input  $V_{in} \leq V_1$  (for input  $V_{in} > V_1$  it will charge in the opposite direction).

The output is captured at two instants using the two output comparators at voltage references  $V_2$  and  $V_3$ . The time corresponding to voltage levels  $V_2$  and  $V_3$  are  $T_2$  and  $T_3$  respectively. The final reading of time  $T_m$  is taken as the difference of  $T_3$  and  $T_2$ .

The input voltage is calculated from this difference through the formulae given in the circuit analysis.

This technique can only be used where the input voltage varies slowly, otherwise the charging of the capacitor will be non-linear.

### 2.1 Advantage of using two comparators

The purpose of using the second comparator (comp2) can be understood from the diagram below (*Figure 2*), which shows the relationship between the op-amp output (Amp in *Figure 1*) and the time for a given input value.

**Figure 2. Relationship between  $V_{out}$  and time for a given input**

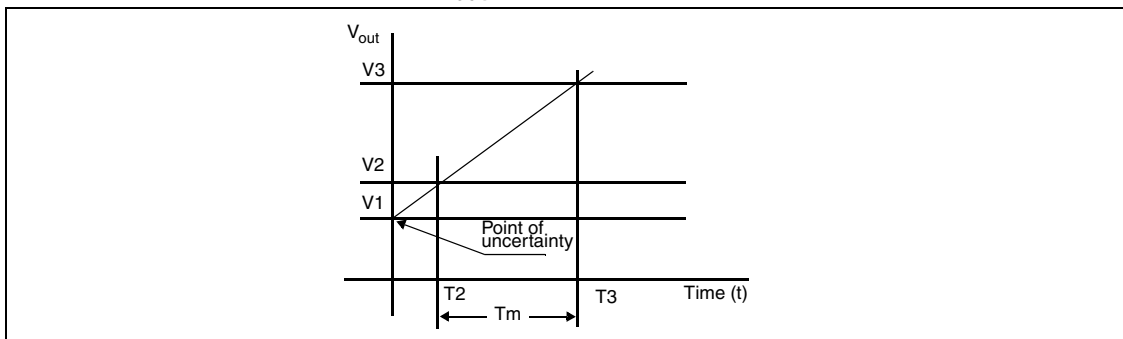

The time is measured as the difference of the two timer readings ( $T_3 - T_2$ ) for the same slope. So factors like the residual voltage of the capacitor ( $V_c(0+)$ ) and any other constant errors (like the effect of output offset voltage) on the output side of the op-amp are subtracted. So its performance is better than a single-slope converter.

### 3 Timing diagram

Figure 3 shows the overall operation of the ADC. Initially the capacitor is in the reset state (M1- ON and M2- OFF), the op-amp output  $V_{out}$  is at  $V_1$  and so, the output of both comparators, Comp1 and Comp2 is HIGH.

Capacitor charging can be started by switching M1 - OFF and M2 - ON. When the charging starts,  $V_{out}$  rises. When  $V_{out}$  becomes greater than  $V_2$ , a falling edge occurs on Comp1. This causes an input capture at pin PB2 and software reads the timer value  $T_2$ .

When  $V_{out}$  becomes greater than  $V_3$ , a falling edge occurs on Comp2. Again this causes an input capture at pin PB0 and software reads the timer value  $T_3$ .

The capacitor is discharged by switching M1 - ON and M2- OFF. After this, the ADC can be kept in reset condition by switching M1 - ON and M2 - OFF or we can continue repeating the same process and make more measurements.

Figure 3. Timing diagram

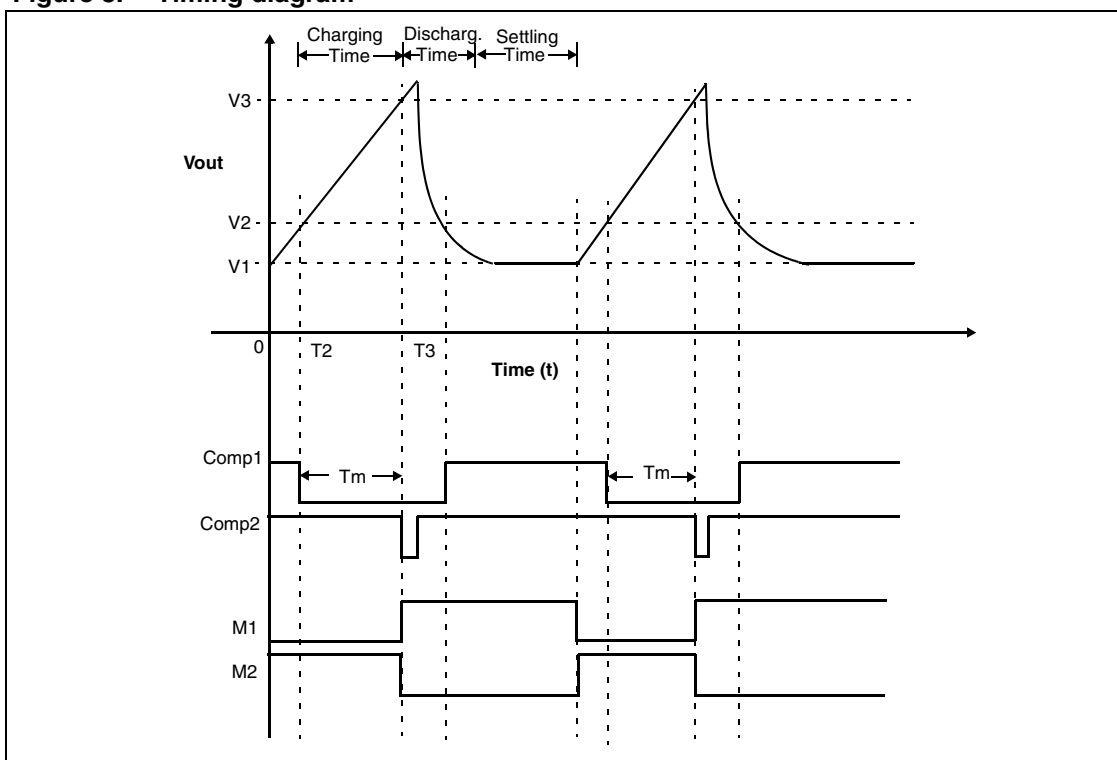

## 4 Circuit analysis

In this analysis, it is assumed that there is no noise present and the i/p offset voltage of the op-amp is negligible.

Now,

$$I = (V_1 - V_{in}) / R = C * dV_c / dt \text{ (where } V_c = V_{out} - V_1)$$

Where, current 'I' is constant for a given input. Applying the Laplace transform:

$$(V_1 - V_{in}) / s * R = C * (s V_c(s) - V_c(0+))$$

or,

$$(V_1 - V_{in}) / s^2 = (R * C) * (V_c(s) - V_c(0+) / s)$$

Applying the inverse Laplace transform, we get

$$(V_1 - V_{in}) * T = (R * C) * (V_c(t) - V_c(0+)) \quad \text{----- (1)}$$

Now as shown in the Timing Diagram -

$$\text{At } T = T_2; \quad V_c(T_2) = V_2 - V_1$$

$$\text{And, at } T = T_3; \quad V_c(T_3) = V_3 - V_1$$

So,

$$(V_1 - V_{in}) * T_2 = (R * C) * (V_2 - V_1 - V_c(0+)) \quad \text{----- (2)}$$

And,

$$(V_1 - V_{in}) * T_3 = (R * C) * (V_3 - V_1 - V_c(0+)) \quad \text{----- (3)}$$

Equation (2) and equation (3) can both be used as the characteristic equation for this converter, but factors like  $V_c(0+)$  and other constant errors remain present. But if we use both comparators, then we can remove these factors by subtracting equation (2) and equation (3).

Now after subtracting equation (2) from equation (1) and rearranging we get-

$$V_{in} = V_1 - (R * C) * (V_3 - V_2) / (T_3 - T_2) \quad \text{----- (4)}$$

Let measured time  $T_3 - T_2 = T_m$ . So we get:

$$V_{in} = V_1 - (R * C) * (V_3 - V_2) / T_m \quad \text{----- (5)}$$

By using equation (5) we can measure the value of  $V_{in}$  depending on the value of  $T_3$  and  $T_2$ .

## 5 Vout vs time diagram for different input voltages

In *Figure 4*, we can see the relationship between the  $V_{out}$  and time for different input voltages. From the figure, it is clear that the conversion time for a negative input voltage is less than the time taken for a positive input voltage.

**Figure 4. Vout Vs Time For Different Input Voltages**

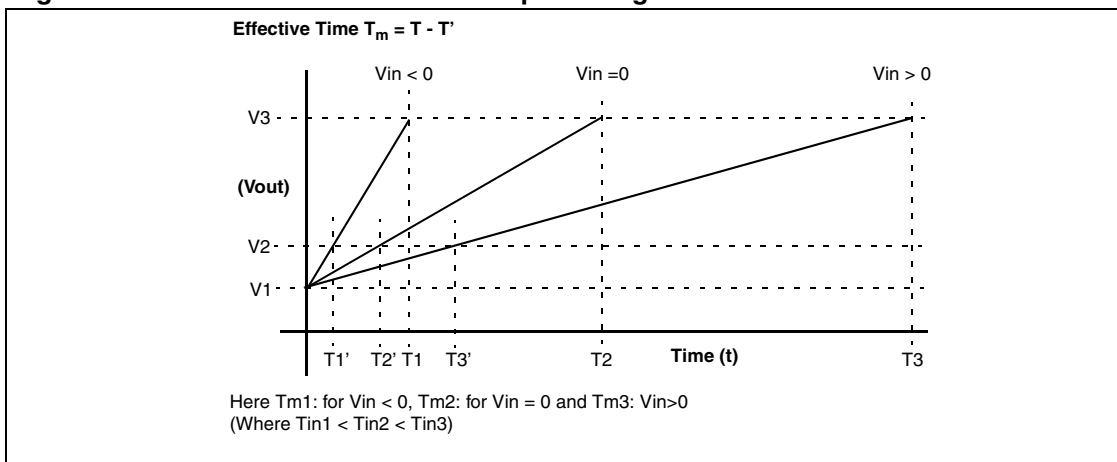

1. This ADC works for the range  $V_{in} \leq V_1$  but if the input voltage is greater than  $V_1$  the direction of current  $I$  will be inverted and the capacitor will start charging in the opposite direction and conversion will never take place.
2. For negative voltages current  $I$ , that depends on the difference  $V_1 - V_{in}$ , will be high, so the charging time for negative voltages will be less than the positive voltages.



## 6 Characteristics of different slope converters

### 6.1 Single-slope converter

Figure 5. Single-Slope Converter Circuit Diagram

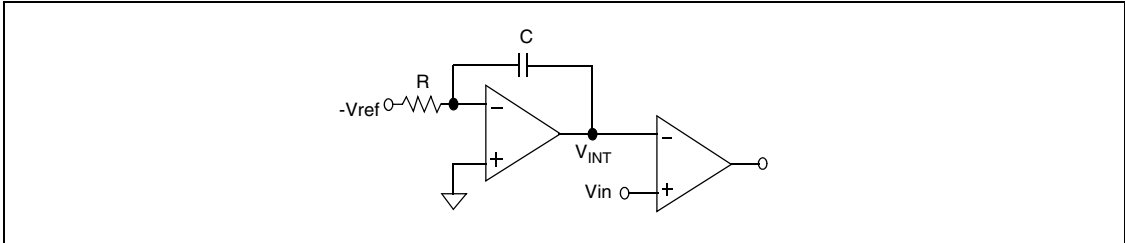

#### 6.1.1 Timing diagram

Here  $V_{in}$  is directly proportional to the time measured.

Figure 6. Single-slope converter timing diagram

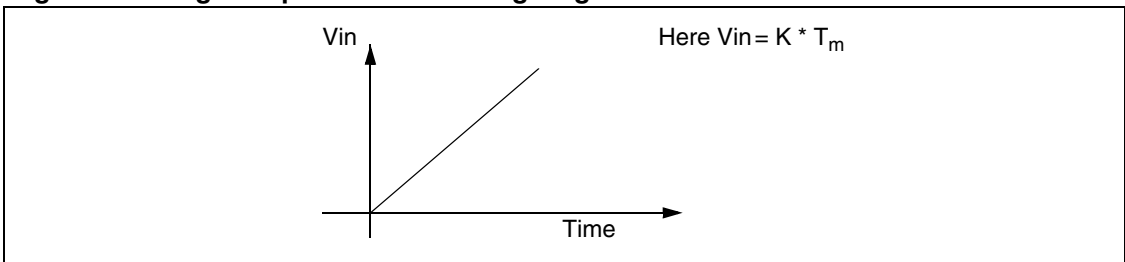

The major sources of conversion errors are the correction factor for the  $R \cdot C$  product and the input offset voltage.

A single-slope converter requires a dual supply voltage op-amp to be able to measure the positive and negative voltages.

## 6.2 Dual-slope converter

Figure 7. Dual-slope converter circuit diagram

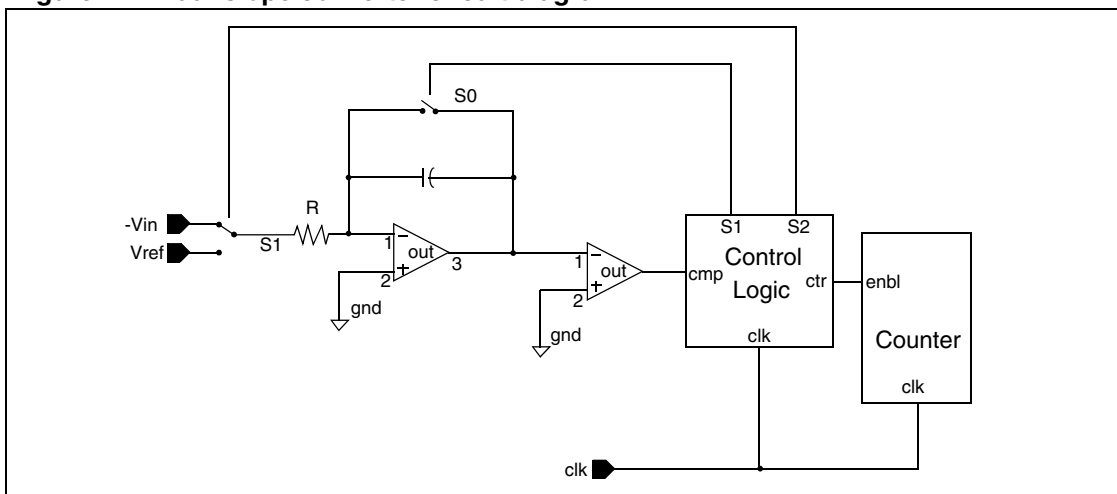

### 6.2.1 Timing diagram

As shown in [Figure 8](#) a dual-slope ADC has a charging phase followed by a fixed rate discharging phase.

Figure 8. Dual-slope converter timing diagram

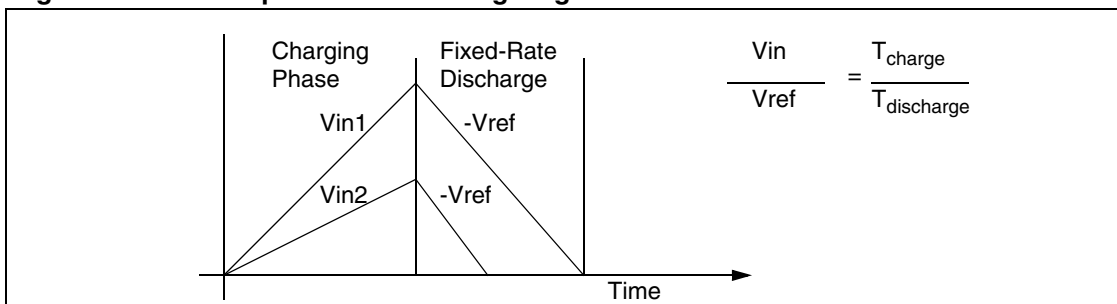

The advantage of a dual-slope ADC is that it is not dependent on the correction factor for the  $R \cdot C$  product. However, the input offset voltage problem still persists here and this ADC also requires a dual supply op-amp to be able to measure the positive and negative voltages.

## 6.3 Solution presented in this application note

In this converter, the input voltage is proportional to the inverse of the time measured. We can see in [Figure 9](#), as the input voltage becomes closer to  $V_1$ , the conversion time also increases. For an input of  $V_1$ , the conversion time will be infinite ( $1/T_m = 0$  in [Figure 9](#)). So the input voltage range depends on the value of  $V_1$  and the maximum delay that the application can tolerate.

Figure 9.  $V_{IN}$  versus Time in AN1812 solution

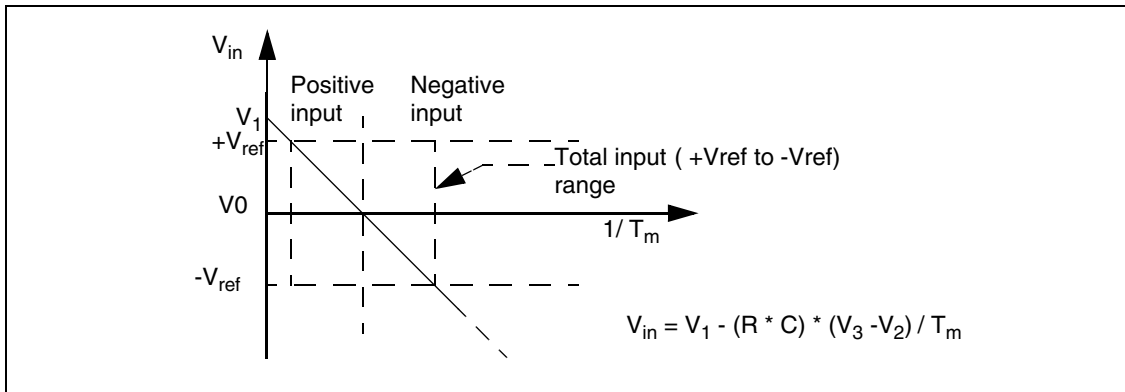

The significant advantage of this converter is the ability to measure positive and negative input voltages operating from single supply, while other solution require a dual supply. Also this converter does not require any negative voltage reference. Again, as in the single slope converter, the major sources of error are the correction factor for  $R * C$  product and the input offset voltage.

As shown [Figure 9](#), the ADC is capable of measuring the input voltage ranging  $+V_{ref}$  to  $-V_{ref}$ , where the absolute value of  $V_{ref}$  is mod  $(V_{ref}) < V_1$  so the input voltage range depends on the value of  $V_1$ .

## 7 Error analysis / constraints

This ADC can be used for measuring any slowly varying input (voltage/current), for example battery monitoring, and for measuring positive and negative input voltages. But besides the need for accurate power supply and voltage references, the following factors also affect the accuracy of the conversion.

### 7.1 Input offset voltage

As mentioned previously, the output offset voltage is subtracted from the input, but the input offset voltage of the op-amp (Amp) still remains present and is directly added to  $V_1$ . For measurement purposes, let's refer to the input offset voltage of the Op-amp as  $K_{\text{offset}}$ .

### 7.2 Correction factor for the product of R\*C

As the value of the R and C changes with time and temperature, the factor  $R * C$  will also change. Let the correction factor be  $K_{\text{gain}}$ .

Then eq(5) becomes,

$$V_{\text{in}} = V_1 + K_{\text{offset}} - K_{\text{gain}} * (R * C) * (V_3 - V_2) / T_m \quad \text{----- (6)}$$

The coefficients  $K_{\text{offset}}$  and  $K_{\text{gain}}$  can be calculated by measuring  $T_m$  for two known input values. These factors can also be compensated by software calibration techniques (like using look-up tables or storing some known values). In the present example the first method is used to calculate these coefficients.

### 7.3 Value of charging resistance R

If the **Charging Resistance R** is too high then the current 'I' will be comparable to the input bias current of the Op-amp, which can affect the output. Also if it is too low then the current flowing through it will be significant so the capacitor will be charged very fast. This will affect the measurement accuracy of the ADC.

### 7.4 Charging capacitor C

Up to this point we have assumed that capacitor C discharges completely from the previous conversion. However, this is not so in actual practice and a few millivolts worth of charge (which adds to the offset voltage), may remain on the capacitor. This effect is called capacitor dielectric absorption and varies depending on the capacitor's dielectric material voltage to which it was charged during the last charge cycle and the amount of time the capacitor has had to discharge. Also due to this effect, the output of the capacitor may not be linear over the whole conversion range. So it is very important to choose the right capacitor for your requirements. While Teflon capacitors exhibit the lowest dielectric absorption, polystyrene and polyethylene are also excellent. Ceramic, glass and mica are fair, while tantalum and electrolytic types are poor choices for A/D applications.

Also, as integrating ADC's are dependent on the integration of the current flowing through capacitor C, they basically do the averaging. So the larger the value of the capacitor, the longer

the conversion time and the better the accuracy will be. So there is always a trade-off between conversion time and accuracy.

## 7.5 16-bit TIMER

A 16-bit timer is used as the counter that measures the conversion time. Overflows are also taken into account, so we can also use an 8-bit timer. The resolution of the ADC depends on the operating frequency of the timer.

## 7.6 Effect of temperature

The value and characteristics of each component vary with temperature. The effect of temperature can be broadly categorized as offset drift and gain drift. So we need to compensate the ADC for each significant change in temperature.

## 7.7 Comparator

The comparators are the cornerstone of the A/D conversion process. The ability of the comparator to detect small voltage/current changes makes the comparator very important in the A/D conversion process. So any degradation of the intended behaviour of the comparator, which is most usually caused by unwanted noise, will lead to the degradation of the ADC's ability to measure low voltages.

## 8 Voltage references

The following circuit is used to produce the different voltage references.

**Figure 10. Voltage Reference**

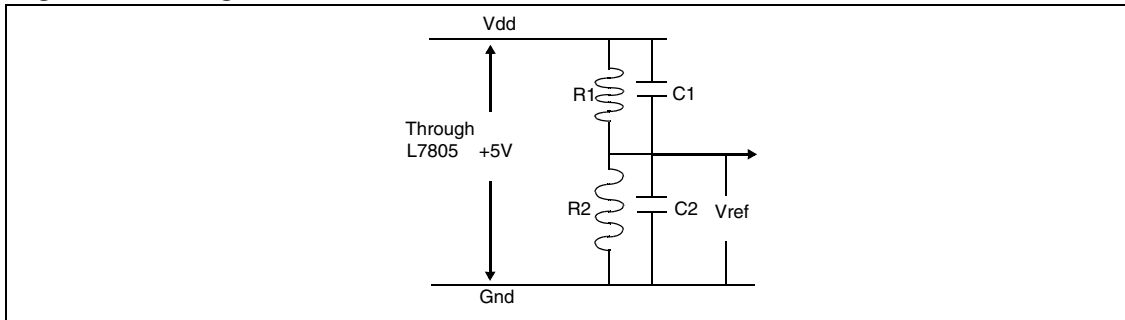

## 9 Hardware setup

Figure 11. Hardware Setup

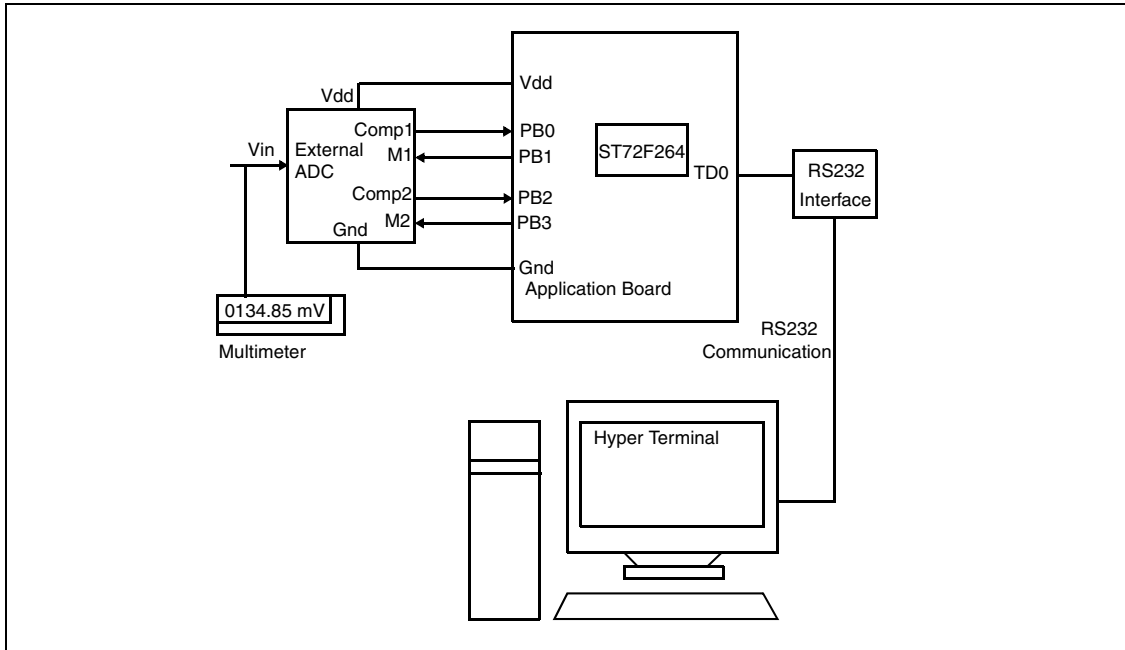

The external ADC is interfaced to the ST72F264. The input capture pins PB0 and PB2 are used for capturing the pulse from the comparators at two instants (when the output is equal to  $V_2$  and  $V_3$  respectively), while PB1 and PB3 are used for controlling the voltage at the gate of the M1 and M2 switches (ON / OFF the Mosfet). The results of the A/D conversion are displayed on the Windows HyperTerminal application through an RS232-SCI interface. The general schematics of the board are given in [Appendix B: Application board schematics](#).

# 10 Algorithm

Figure 12. Algorithm flowchart

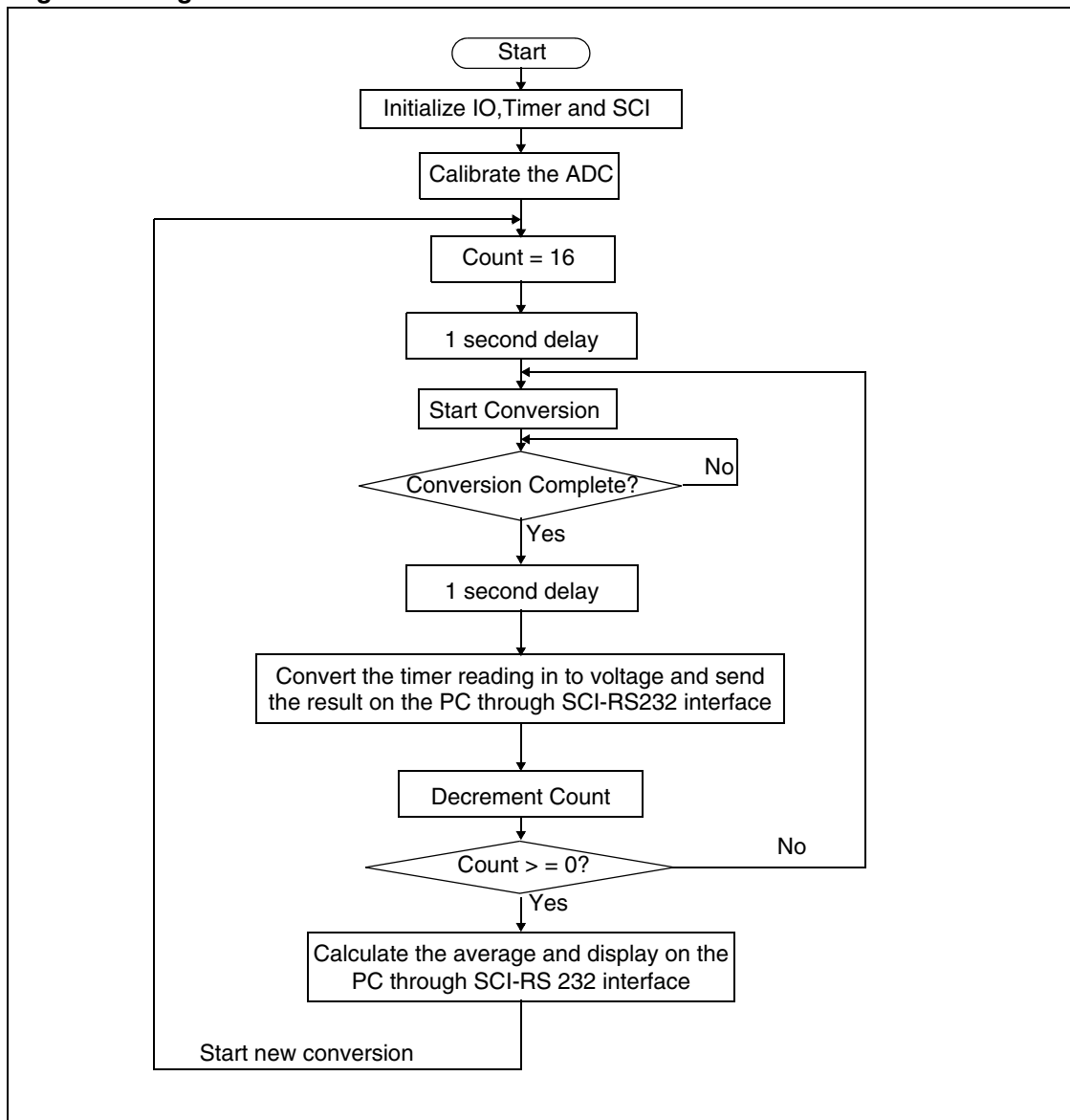



# 11 Result

The result is given for a capacitor value of 100 uF. So the conversion time is long. We can reduce the conversion time by choosing a capacitor with a lower value but accuracy will also be reduced. Other parameters are as follows:

$$R = 10 \text{ K}, V_1 = 1.5\text{V}, V_2 = 2\text{V} \text{ and } V_3 = 3\text{V}$$

So:

$$R * C = (10 \text{ K}) * (100 \text{ uF}) = 1\text{s}$$

The input range is taken as +1 V to -1 V, where mod ( $V_{ref}$ ) (= 1V) is less than  $V_1$ .

The conversion time is in the range 1 to 3s. The settling time (As shown in [Figure 3](#)) is kept fixed at 1s. The ADC is calibrated by reading two known input voltages and then  $K_{offset}$  and  $K_{gain}$  are calculated. The input voltage  $V_{in}$  is taken from a voltage source.

## 11.1 Positive input

In [Figure 13](#), an example of the readings measured by the converter, which is sent to Hyper Terminal, is shown. In this  $T_{avg}$  is the average of 16 conversions, and  $V_{avg}$  is the calculated value in terms of voltage. The difference of the maximum and minimum value among the 16 values is also shown.

**Figure 13. Results for positive input**

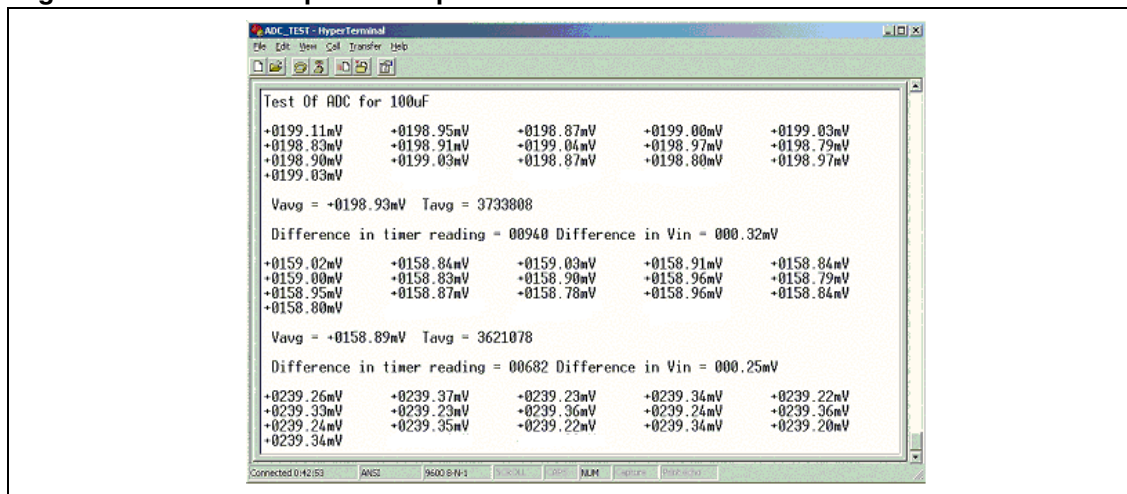

In [Table 1](#), the readings are shown for positive input voltages ranging from 0 to 1V. Here  $V_{in}$  is the voltage measured by the multimeter.  $V_{measured}$  (equal to  $V_{avg}$ ) is the average voltage measured by the converter in a loop of 16. The last column shows the difference in the maximum and minimum readings of the values measured by the converter in the loop. This shows the variations recorded in the readings.

**Table 1. Results for positive input voltages**

SI no	Vin ( Taken from Multi-meter) (mV)	Vmeasured (mV)	Difference (Vmeasured - Vin) (mV)	Error in Max and min input measured in the loop (mV)
1	8.93	8.93	0	0.45
2	18.94	18.98	0.04	0.25
3	28.82	28.87	0.05	0.21
4	38.72	38.78	0.06	0.39
5	49.07	49.13	0.06	0.46
6	58.93	59.02	0.09	0.38
7	68.82	68.92	0.1	0.08
8	79.12	79.25	0.13	0.39
9	88.98	89.07	0.09	0.33
10	98.85	98.98	0.13	0.12
11	108.75	108.9	0.15	0.37
12	119.05	119.19	0.14	0.43
13	128.95	129.13	0.18	0.29
14	138.57	138.76	0.19	0.24
15	158.75	158.96	0.25	0.25
16	178.97	179.18	0.21	0.4
17	198.68	198.91	0.23	0.1
18	218.83	219.1	0.27	0.37
19	239.08	239.35	0.27	0.34
20	258.55	258.83	0.28	0.14
21	278.8	279.11	0.31	0.19
22	299.02	299.34	0.32	0.31
23	318.68	319.09	0.41	0.37
24	338.93	339.29	0.36	0.35
25	358.38	358.78	0.4	0.39
26	378.62	378.98	0.36	0.36
27	398.85	399.25	0.4	0.27
28	438.84	439.23	0.39	0.15
29	478.64	478.93	0.29	0.35
30	498.75	499.23	0.48	0.09
31	519	519.41	0.41	0.32
32	538.69	539.1	0.41	0.28
33	558.91	559.3	0.39	0.11
34	578.63	579.03	0.4	0.3
35	598.65	599.01	0.36	0.28
36	638.6	638.99	0.39	0.26

Sl no	V <sub>in</sub> ( Taken from Multi-meter) (mV)	V <sub>measured</sub> (mV)	Difference (V <sub>measured</sub> - V <sub>in</sub> ) (mV)	Error in Max and min input measured in the loop (mV)
37	678.93	679.3	0.37	0.14
38	718.6	718.93	0.33	0.14
39	758.61	758.93	0.32	0.23
40	798.53	798.83	0.3	0.17
41	838.7	838.94	0.24	0.19
42	858.49	858.68	0.19	0.2
43	878.55	878.72	0.17	0.13
44	898.76	898.92	0.16	0.19
45	918.53	918.61	0.08	0.13
46	938.46	938.55	0.09	0.15
47	958.68	958.72	0.04	0.1
48	978.4	978.38	-0.02	0.14
49	998.63	998.56	-0.07	0.14
50	1018.8	1018.68	-0.12	0.18

Figure 14 shows the relationship between the voltage measured by the ADC V<sub>measured</sub> (Average of the 16 readings measured by the converter) and the input voltage V<sub>in</sub>.

Figure 14. Measured vs input for positive voltages

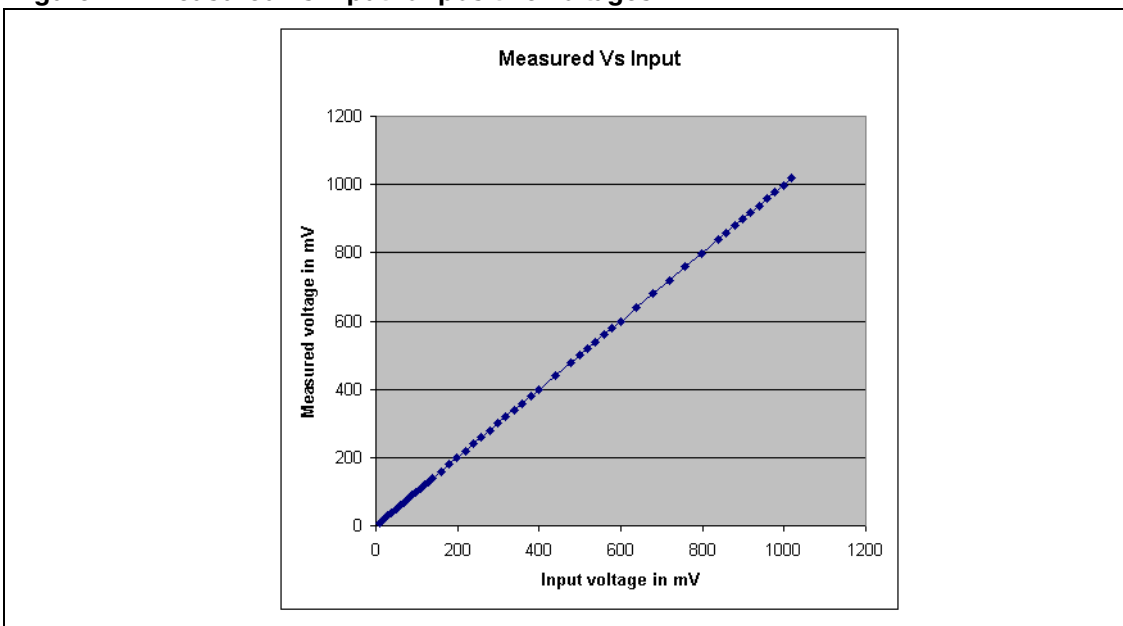
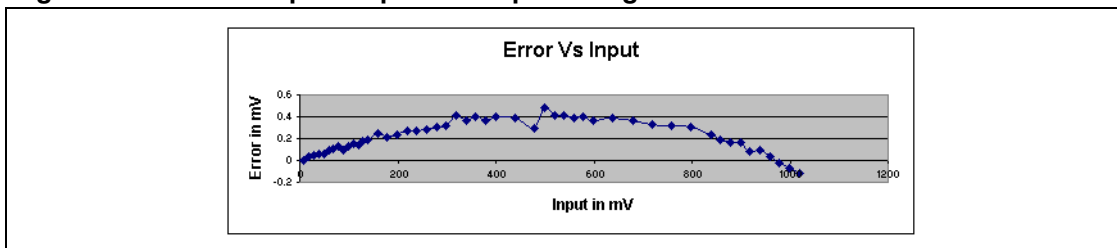

Figure 15 shows the relationship between the error voltage (As given in column “Difference (V<sub>measured</sub> - V<sub>in</sub>)” in Table 1) and the input voltage V<sub>in</sub>.

**Figure 15. Error vs input for positive input voltages**



*Note:* From the readings (Table 1, Figure 15), we can notice that for the positive input between 0 to 1V the maximum error is around 500  $\mu$ V for the average of 16 conversions. The difference between the maximum and minimum values in a loop of 16 is around 500  $\mu$ V. This shows that averaging has increased the accuracy. The accuracy without averaging is approx 1mV.

The variations in 16 values can be due to changes in the input voltage itself, as the time taken for 16 readings is very long (around 16 s).

## 11.2 Negative input

Similar to the positive input voltages, the readings for negative input voltages are taken in a loop of 16 as shown in Figure 16.

**Figure 16. Results for negative input**

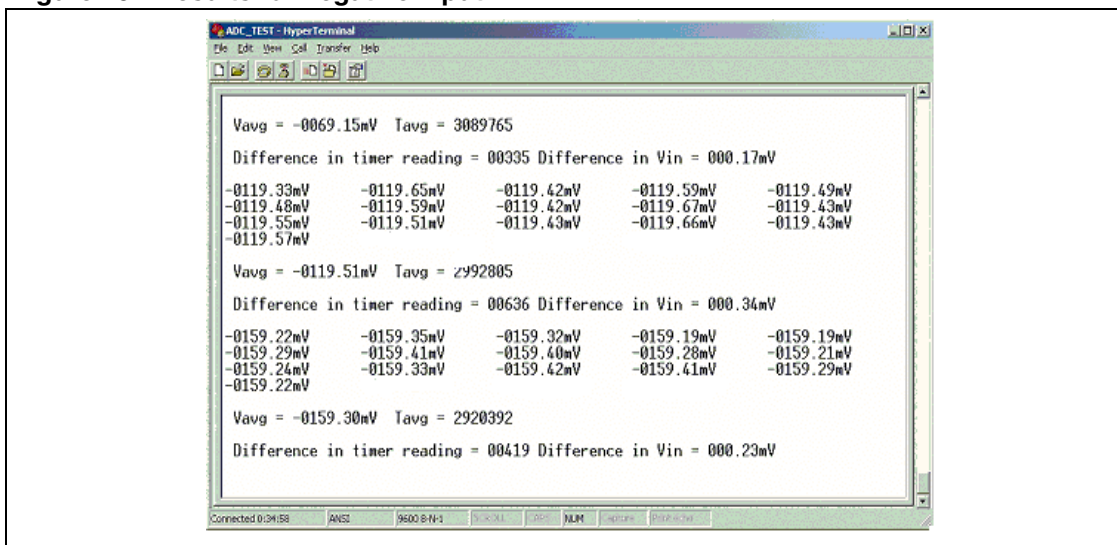

Table 2 shows the readings for negative input voltages ranging from 0 to -1V with same parameter notations.

**Table 2. Results for negative input voltages**

SI no	Vin (Taken from Multi-meter) (mV)	Vmeasured (mV)	Difference (Vmeasured - Vin) (mV)	Error in Max and min input measured (mV)
1	-9.23	-9.17	0.06	0.43
2	-18.92	-18.84	0.08	0.14
3	-28.96	-29.04	-0.08	0.27

Sl no	Vin (Taken from Multi-meter) (mV)	Vmeasured (mV)	Difference (Vmeasured - Vin) (mV)	Error in Max and min input measured (mV)
4	-38.76	-38.89	-0.13	0.38
5	-49.03	-49.14	-0.11	0.37
6	-58.88	-59	-0.12	0.24
7	-68.74	-68.9	-0.16	0.8
8	-79.03	-79.2	-0.17	0.22
9	-88.88	-89.06	-0.18	0.34
10	-98.76	-98.96	-0.2	0.4
11	-128.87	-129.13	-0.26	0.32
12	-148.76	-149.07	-0.31	0.32
13	-178.9	-179.21	-0.31	0.39
14	-198.6	-198.94	-0.34	0.11
15	-218.73	-219.12	-0.39	0.43
16	-248.59	-249.04	-0.45	0.2
17	-268.81	-269.32	-0.51	0.46
18	-298.91	-299.51	-0.6	0.15
19	-318.61	-319.25	-0.64	0.38
20	-348.67	-349.37	-0.7	0.37
21	-378.42	-379.23	-0.81	0.23
22	-398.71	-399.57	-0.86	0.48
23	-418.45	-419.33	-0.88	0.25
24	-448.52	-449.5	-0.98	0.47
25	-478.36	-479.41	-1.05	0.26
26	-498.56	-499.69	-1.13	0.4
27	-538.52	-539.73	-1.21	0.38
28	-578.4	-579.8	-1.4	0.47
29	-618.63	-620.1	-1.47	0.19
30	-658.52	-660.17	-1.65	0.53
31	-698.51	-700.28	-1.77	0.26
32	-738.65	-740.44	-1.79	0.16
33	-778.54	-780.59	-2.05	0.37
34	-818.25	-820.42	-2.17	0.43
35	-858.27	-860.61	-2.34	0.56
36	-898.57	-901.07	-2.5	0.2
37	-938.31	-940.94	-2.63	0.67
38	-978.21	-981.03	-2.82	0.43

Figure 17 shows the relationship between measured voltages  $V_{\text{measured}}$  (average of the 16 readings measured by the converter) and input voltage  $V_{\text{in}}$  (As measured by the multimeter) for negative voltages.

**Figure 17. Measured vs input for negative voltages**

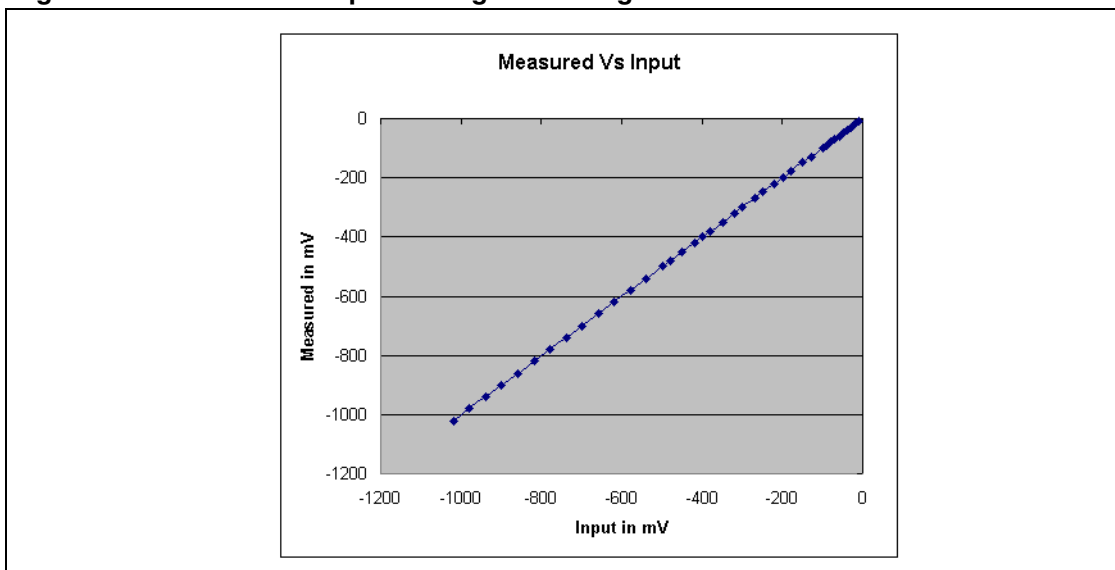

**Figure 18. Error vs input for negative input voltages**

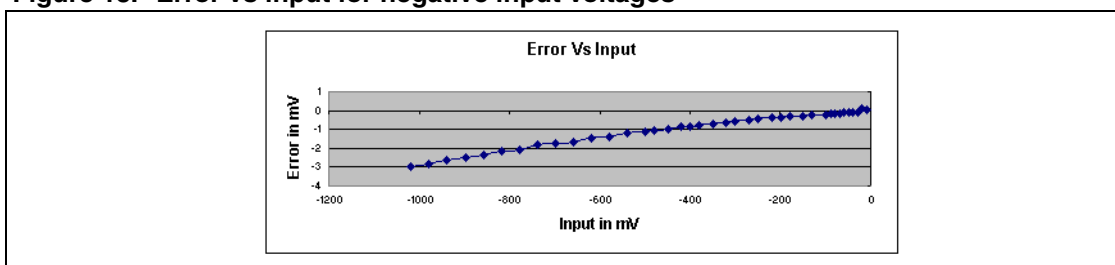

Note: In Figure 18, we see that for the negative input voltages varying from 0 to -1V, the maximum error is around -2.89mV for -1V input. The error of 0.5 mV occurs for the input value of -269 mV and it increases gradually afterwards. The maximum difference between maximum value and the minimum in loop is around 600  $\mu$ V. So the accuracy of the average value measured is around 3 mV, and without averaging the accuracy is around 3.6 mV.

### 11.3 Effect of the capacitor value

As discussed in error analysis ([Section 7](#)), reducing the  $R \cdot C$  time constant by reducing the value of R or C, will reduce the accuracy. We have also taken the reading for the capacitor value of 10  $\mu$ F. This shows that the accuracy of the ADC is reduced. An example is given in [Figure 19](#) of readings with a 10  $\mu$ F capacitor.

Figure 19. Results for positive input for 10uF

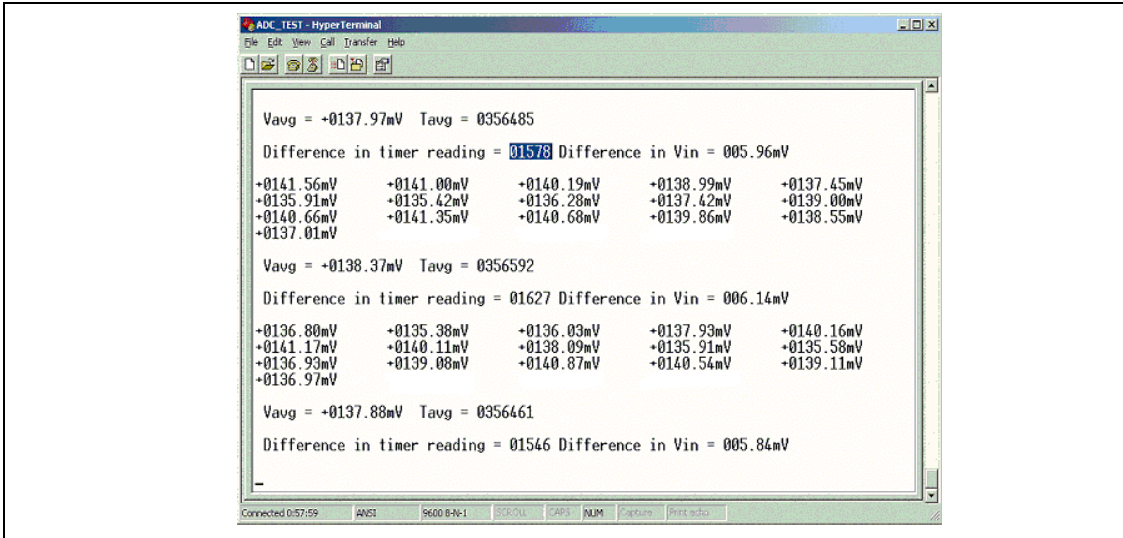

From the readings, we notice that the variation in the readings taken in a loop of 16 is around 5 - 6 mV which is approximately 10 times higher than the readings for the 100 uF. So there is always a trade-off between conversion time and the desired accuracy.

## 12 Conclusion

In this application note, a technique is given for implementing a positive supply ADC capable of measuring slowly-varying positive and negative input voltages with high precision.

The accuracy of the converter depends on the different parameters. Better results can be achieved with careful board design and more precise components and keeping in mind all the factors which are discussed in this Application Note.



## 13 References and bibliography

- ST72F264 Datasheet

In addition to the material directly referenced, the following articles and reports provide useful information:

1. AN1636 - "Understanding And Minimising ADC Conversion Errors".
2. "Comparators and Bistable Circuits", ECE60L Lecture Notes, Winter 2002.
3. "Selecting the Right Buffer Operational Amplifier for an A/D Converter", Application Report SLOA050 – August 2000, Texas Instruments.
4. "MOSFET Device Physics and Operation" by T. Ytterdal, Y. Cheng and T. A. Fjeldly  
© 2003 John Wiley & Sons, Ltd ISBN: 0-471-49869-6.
5. "Comparators and Offset Cancellation Techniques" by Jieh-Tsorng Wu February 25, 2003, National Chiao-Tung University Department of Electronics Engineering.
6. "Reducing Noise in Data Acquisition Systems" by Fred R. Schraff, P.E., IOtech Inc.  
Adapted from an article that appeared in the April 1996 edition of SENSORS Magazine, Helmers Publishing.
7. "How do ADCs work?" by Martin Rowe, Senior Technical Editor - 7/1/2002 Test & Measurement World.

## Appendix A Input stage conditions

We can use this ADC for measuring both voltage and current but with a slight change in the set-up in each case.

### A.1 Case 1: voltage measurement

There are two ways in which the input voltage will appear at the ADC input. The first condition is that input is coming directly from a voltage source as shown in [Figure 20](#).

**Figure 20. Voltage measurement**

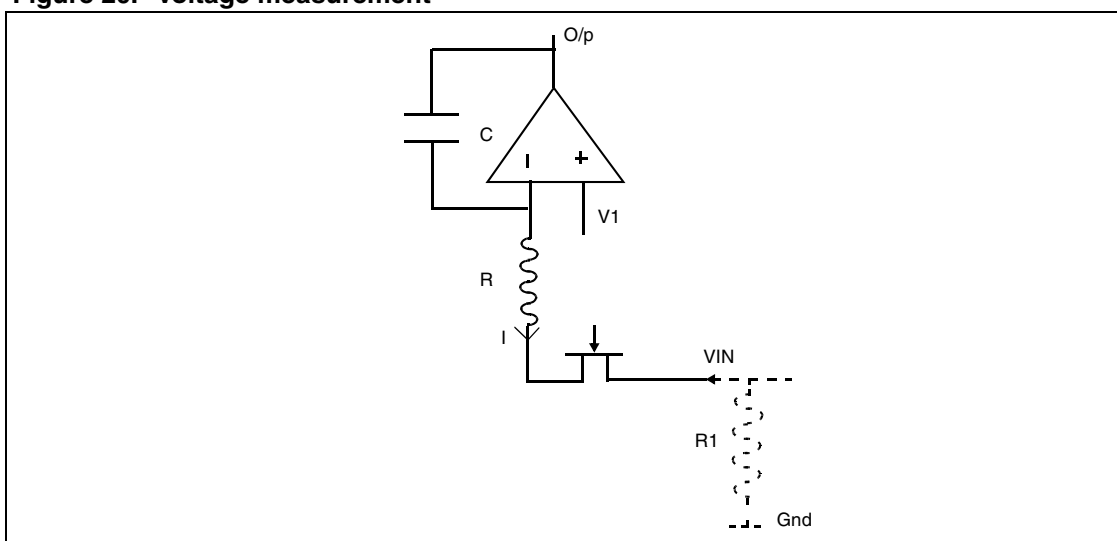

There is no problem in the above case. But if the input comes from a potential divider circuit as shown in [Figure 21](#) then the effective input voltage  $V_{in}$  is the result of the drop across  $R2$  due to the current  $I$  and current  $I_{in}$ .

**Figure 21. Potential divider**

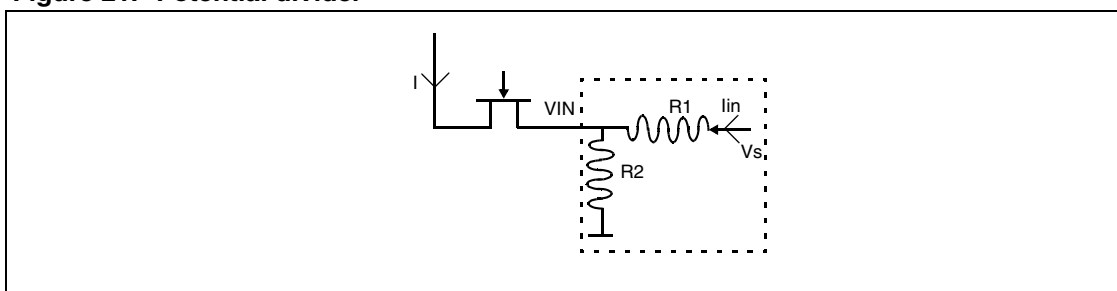

In this case we have to use an input buffer to overcome this problem as shown in [Figure 22](#).

**Figure 22. Use of Input buffer for voltage measurement**

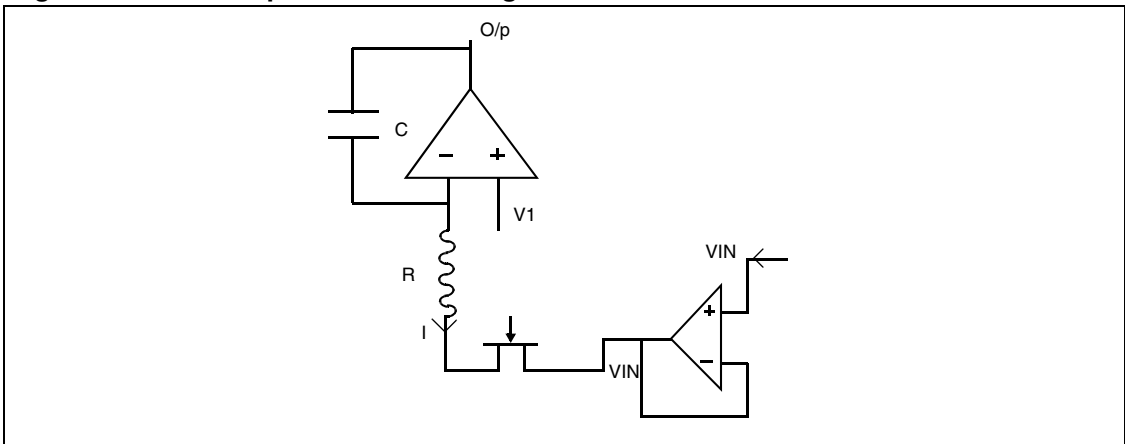

## A.2 Case 2: Current measurement

Figure 23 shows the current measurement circuit.

**Figure 23. Current measurement**

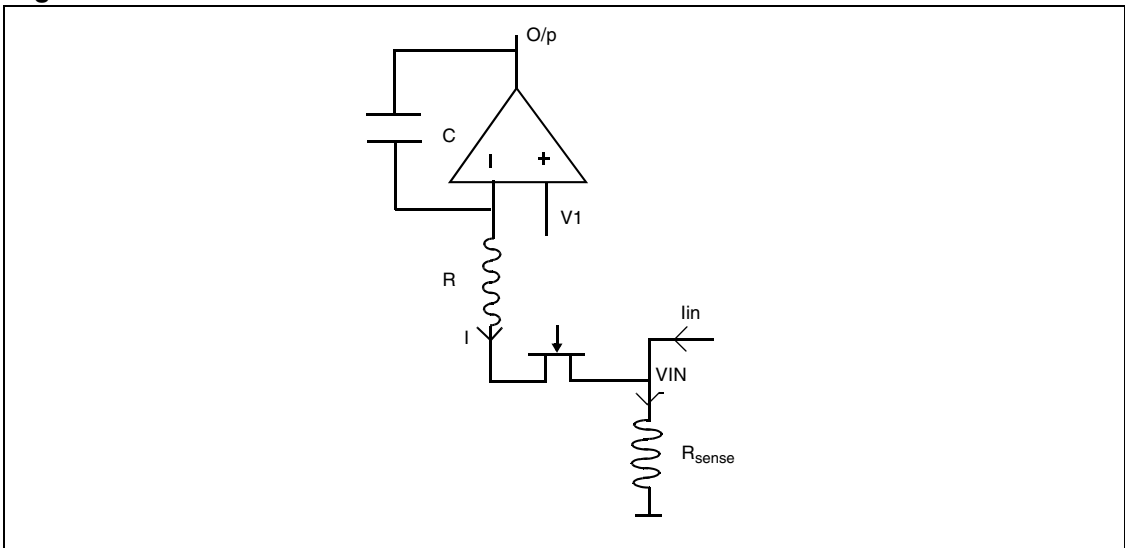

$$V_{in} = (I_{in} + I) * R_{sense} = I_{in} * (1 + I / I_{in}) * R_{sense} \quad \text{----- (1)}$$

$$I = (V_1 - V_{in}) / R = V_1 / (R * (1 + R_{sense} / R)) \quad \text{----- (2)}$$

So the following points should be kept in mind while using  $R_{sense}$ .

1.  $R_{sense}$  should be chosen to correspond to the range of the current to be measured.
2.  $R_{sense}$  affects the effective value of current I. To minimize its effect, it should be negligible compared to R. Otherwise ADC has to be compensated.

# Appendix B Application board schematics

Figure 24. Application board schematics

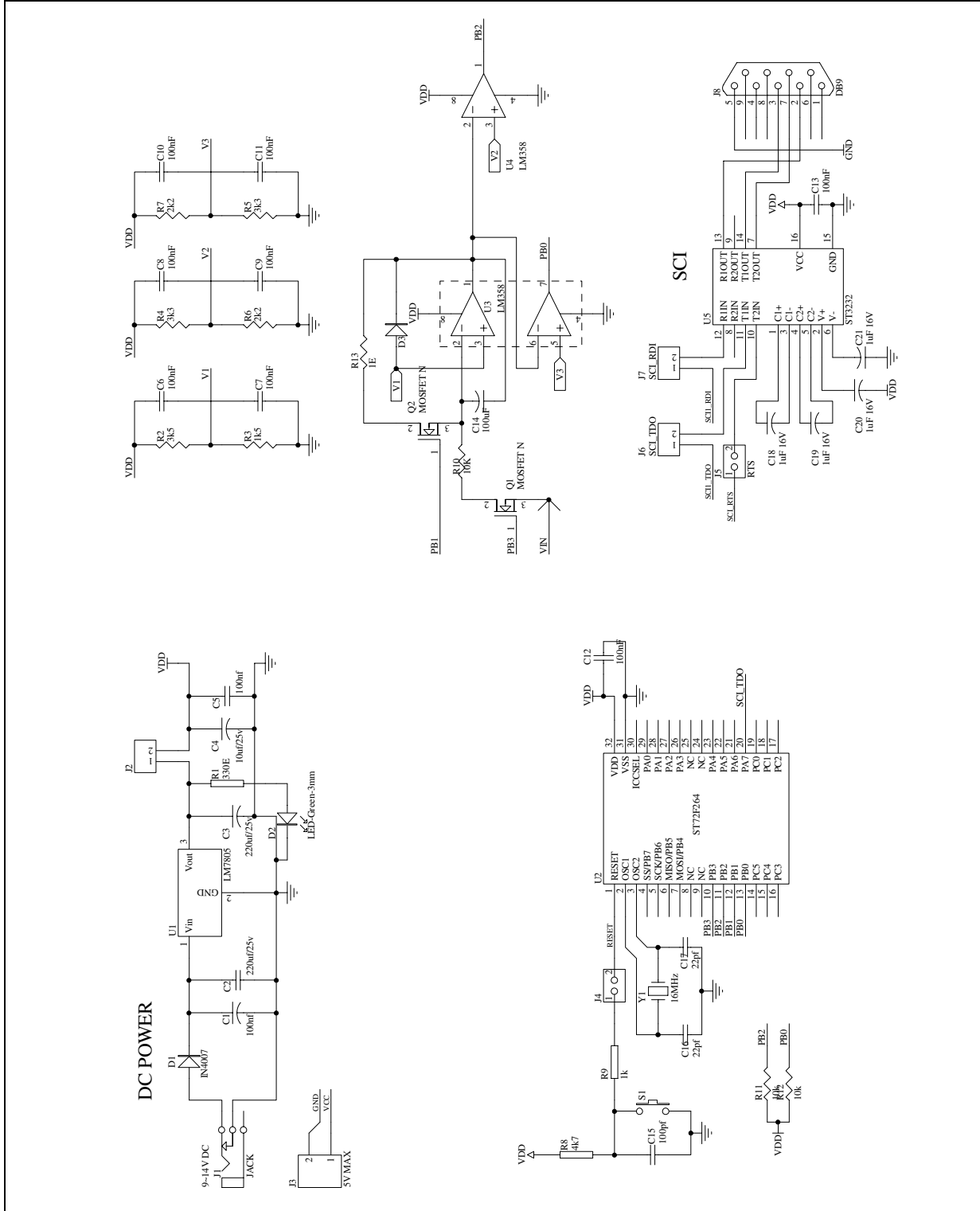

## Appendix C Bill of materials

[Table 3](#) gives the Bill of Material for each block of the schematics shown in [Figure 24](#).

**Table 3. Bill of material**

Block	Designator	Part Type/ Number	Description
ADC	R13	1E	Resistor
	R10	10K	Resistor
	U3	LM358	Dual Op-amp
	U4	LM358	Dual Op-amp
	C14	100uF	Capacitor
	Q2	STB100NF03L	N - MOSFET
	Q1	STB100NF03L	N - MOSFET
	D3	IN4007	Diode
Voltage References	C8	100nF	Capacitor
	C9	100nF	Capacitor
	C10	100nF	Capacitor
	C11	100nF	Capacitor
	C7	100nF	Capacitor
	C6	100nF	Capacitor
	R6	2k2	Resistor
	R7	2k2	Resistor
	R5	3k3	Resistor
	R4	3k3	Resistor
	R2	3k5	Resistor
	R3	1k5	Resistor
SCI	U5	ST3232	Line Driver
	C18	1uF 16V	Capacitor
	C19	1uF 16V	Capacitor
	C20	1uF 16V	Capacitor
	C21	1uF 16V	Capacitor
	J5	jumper	CON-2
	J7	jumper	CON-2
	J6	jumper	CON-2
	C13	100nF	Capacitor
	J8	DB9	9 pin connector

Block	Designator	Part Type/ Number	Description
Micro setup	R12	10k	Resistor
	R11	10k	Resistor
	U2	ST72F264	Micro-controller
	C12	100nF	Capacitor
	Y1	16MHz	Crystal oscillator
Crystal	C17	22pf	Capacitor
	C16	22pf	Capacitor
	R9	1k	Resistor
Reset	R8	4k7	Resistor
	C15	100pf	Capacitor
	S1	Push Button	Micro switch
	J4	CON-2	jumper
DC Power	C4	10uf/25v	Capacitor
	C5	100nf	Capacitor
	C1	100nf	Capacitor
	C3	220uf/25v	Capacitor
	C2	220uf/25v	Capacitor
	R1	330E	Resistor
	J1	DC - Jack	DC- JACK
	D2	LED 3mm	LED-Green
	U1	LM7805	Voltage regulator
	D1	IN4007	Diode
	J2	jumper	CON-2
	J3	Power Connector	2 pin connector

## Appendix D Software flow

The  $f_{CPU}$  chosen is 8 MHz.  $K_{offset}$  and  $K_{gain}$  are calculated by taking the reading for two known inputs. The flow of the software, use to implement the algorithm, is as follows:

1. First the I/O pins, Timer, SCI (Tx @ 9600 baud rate) and some global variables used in the ADC are initialized.
2. Then a string is transmitted to check that SCI is working fine.
3. The settling time is kept fixed at 1 second for  $f_{CPU} = 8$  MHz.
4. Some initial readings are taken and ignored while the ADC stabilizes.
5. The control enters an infinite loop.
6. Inside the infinite loop, there is a loop in which ADC captures the timer values 17 times. But the first reading is ignored.
7. The remaining 16 captured values are converted into the corresponding voltages (up to 10  $\mu$ V precision) and then transmitted a PC for display by the Hyperterminal after being converted into a buffer of ASCII characters.
8. The average of 16 timer readings is taken and sent to the Hyperterminal as a time value and a corresponding voltage in the same manner as described above.
9. The difference between the maximum and minimum captured value is also sent to the Hyperterminal in the same way as in step 8.
10. After this step, the software enters an 'IF' loop "if (mCount == 18)", where the ADC is reset in order to measure the next input value. Again a few readings are ignored while the ADC stabilizes. The counter and other global variables are also initialized.
11. After this, the software re-enters the loop of 17 conversions and executes step 6 to step 9. This process continues until you reset the system manually.

### D.1 Code size

The software given is for guidance only. Here the display is done for up to 10  $\mu$ V precision. You can modify and use your own code for the display of the data. The following table summarizes the code size. Depending on the compiler and memory placement, these values can change. The RAM requirements are not provided and you have the choice to place the variables as global or local.

**Table 4. .Code size**

No.	Function Name	Code size ( Bytes)
<b>ADCSys</b>		
1	Acquisition	128
2	Start_Capturing	7
3	Reset_ADC	5
4	ADC_InitializeVar	29
5	IsCaptured	13
6	Delay_Second	44

No.	Function Name	Code size ( Bytes)
7	IO_Init	37
8	TimerA_Init	47
9	Timer_Interrupt_Routine	170
<b>Main</b>		
10	main	1493
11	TIMERA_IT_Routine	38
12	Conversion_TimerReadingToREALInput	116
13	SCI_Init	25
14	SCI_SendBuffer	30
15	SCI_IsTransmissionCompleted	8
16	Dummy_Capturing	26

*Note: Some floating point operations are used in this software for display purposes only. It is left to the user to use the floating point operation or not as per his application requirement.*



## Revision history

Date	Revision	Changes
13-Sep-2005	1	Initial release.

THE PRESENT NOTE WHICH IS FOR GUIDANCE ONLY AIMS AT PROVIDING CUSTOMERS WITH INFORMATION REGARDING THEIR PRODUCTS IN ORDER FOR THEM TO SAVE TIME. AS A RESULT, STMICROELECTRONICS SHALL NOT BE HELD LIABLE FOR ANY DIRECT, INDIRECT OR CONSEQUENTIAL DAMAGES WITH RESPECT TO ANY CLAIMS ARISING FROM THE CONTENT OF SUCH A NOTE AND/OR THE USE MADE BY CUSTOMERS OF THE INFORMATION CONTAINED HEREIN IN CONNECTION WITH THEIR PRODUCTS.

Information furnished is believed to be accurate and reliable. However, STMicroelectronics assumes no responsibility for the consequences of use of such information nor for any infringement of patents or other rights of third parties which may result from its use. No license is granted by implication or otherwise under any patent or patent rights of STMicroelectronics. Specifications mentioned in this publication are subject to change without notice. This publication supersedes and replaces all information previously supplied. STMicroelectronics products are not authorized for use as critical components in life support devices or systems without express written approval of STMicroelectronics.

The ST logo is a registered trademark of STMicroelectronics.  
All other names are the property of their respective owners

© 2005 STMicroelectronics - All rights reserved

STMicroelectronics group of companies

Australia - Belgium - Brazil - Canada - China - Czech Republic - Finland - France - Germany - Hong Kong - India - Israel - Italy - Japan -  
Malaysia - Malta - Morocco - Singapore - Spain - Sweden - Switzerland - United Kingdom - United States of America

[www.st.com](http://www.st.com)