

SM320AF thru SM3100AF

Schottky Barrier Rectifiers
Reverse Voltage 20 to100V Forward Current 3.0A

FEATURES

- * Plastic package has Underwriters Laboratory Flammability Classification 94V-0
- * Low power loss,high efficiency
- * For use in low voltage high frequency inverters, free wheeling,and polarity protection applications
- * Guardring for over voltage protection
- * High temperature soldering guaranteed: 260°C/10 seconds at terminals

Mechanical Data

Case: JEDEC SMA-FL

molded plastic over glass die

Terminals: Plated leads, solderable per MIL-STD-750, Method 2026

Polarity: Color band denotes cathode end

Mounting Position: Any

Weight: 0.0327 g

Handling precaution:None

1.Electrical Characteristic

Maximum & Thermal Characteristics Ratings at 25°C ambient temperature unless otherwise specified.

Parameter Symbol	symbol	SM320 AF	SM330 AF	SM340 AF	SM345 AF	SM350 AF	SM360 AF	SM380 AF	SM3100 AF	Unit
device marking code		S32	S33	S34	S345	S35	S36	S38	S310	
Maximum repetitive peak reverse voltage	V_{RRM}	20	30	40	45	50	60	80	100	V
Maximum RSM voltage	V_{RSM}	14	21	28	31.5	35	42	56	70	V
Maximum DC blocking voltage	V_{DC}	20	30	40	45	50	60	80	100	V
Maximum average forward rectified current lead length (See fig. 1) at TC = 75°C	IF(AV)	3.0								A
Peak forward surge current 8.3ms single half sine-wave superimposed on rated load (JEDEC Method)	I_{FSM}	100								A
Typical thermal resistance (Note 1)	R θ JA R θ JC	150 25								°C/W
Operating junction and storage temperature range	TJ, TSTG	-40 to +150								°C

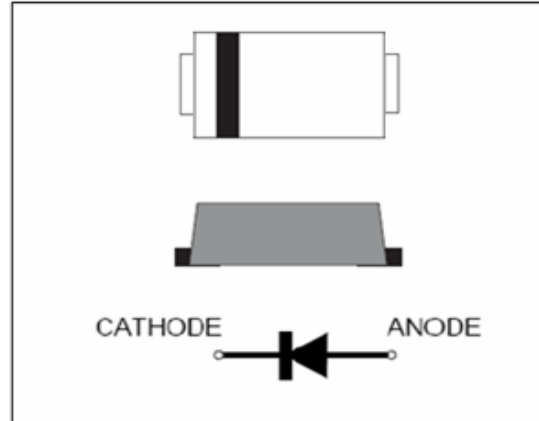

We declare that the material of product is Halogen free (green epoxy compound)

Electrical Characteristics Ratings at 25°C ambient temperature unless otherwise specified.

Parameter Symbol	symbol	SM320 AF	SM330 AF	SM340 AF	SM345 AF	SM350 AF	SM360 AF	SM380 AF	SM3100 AF	Unit
Maximum instantaneous forward voltage at 3.0A	V_F	0.50				0.70		0.85		V
Maximum DC reverse current TA = 25°C at rated DC blocking voltage TJ = 100°C	IR					0.5 30.0				mA
Typical junction capacitance at 4.0V, 1MHz	CJ					110				PF

NOTES:

1. 8.0mm² (.013mm thick) land areas

SM320AF thru SM3100AF

2. Ratings and Characteristic Curves (TA = 25°C unless otherwise noted)

Fig. 1 - Forward Current Derating Curve

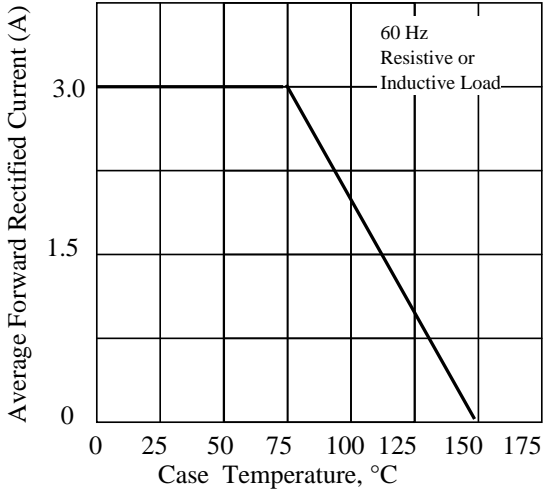

Fig. 2 - Maximum Non-repetitive Peak Forward Surge Current

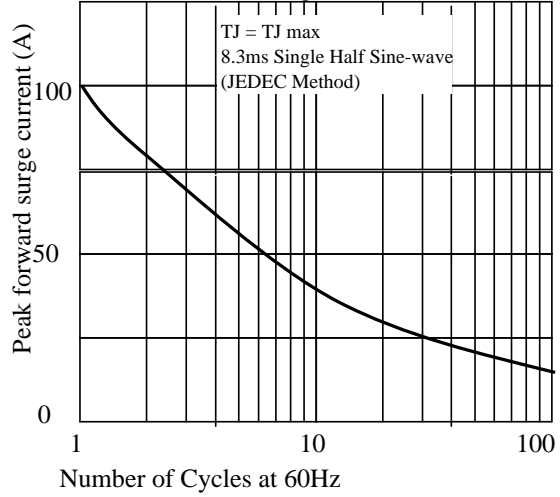

Fig. 3 - Typical Instantaneous Forward Characteristics

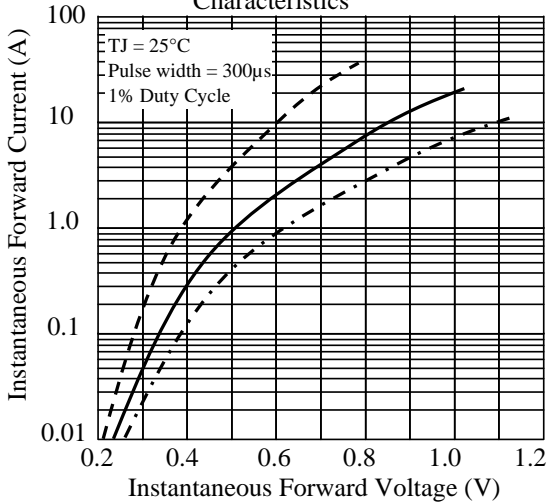

Fig. 4 - Typical Reverse Characteristics

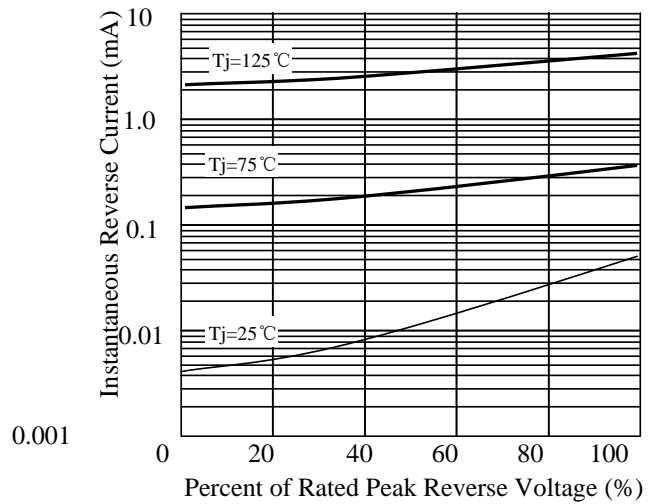

Fig. 5 - typical transient thermal impedance

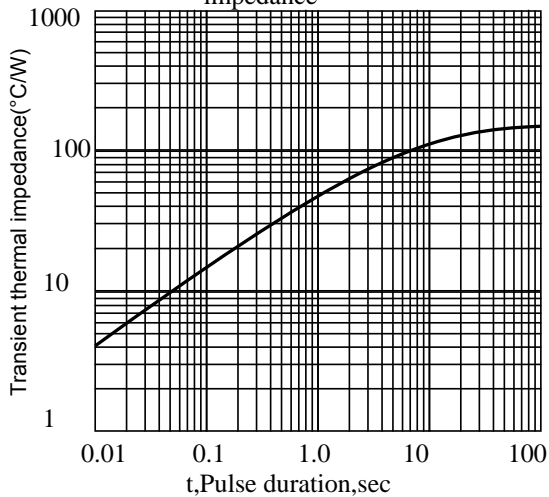
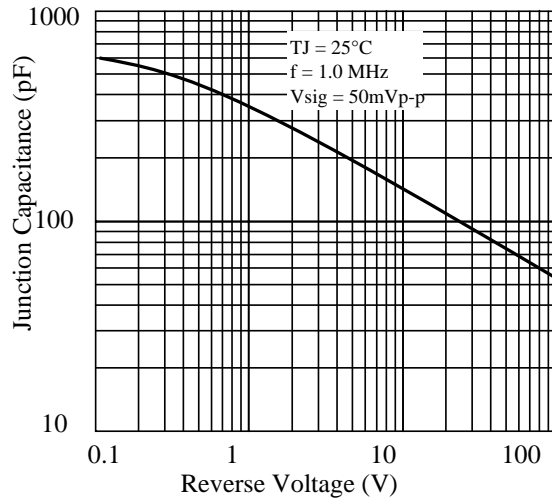

Fig. 6 - Typical Junction Capacitance



SM320AF thru SM3100AF

3. dimension:

SMA-FL

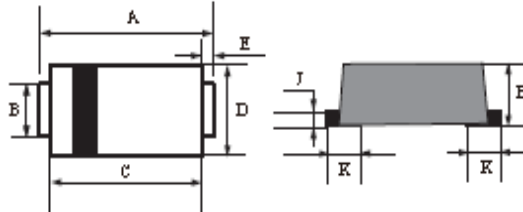

DIM	MILLIMETERS		INCHES	
	MIN	MAX	MIN	MAX
A	4.4	4.8	0.173	0.189
B	1.3	1.5	0.051	0.059
C	3.3	3.7	0.130	0.146
D	2.3	2.7	0.091	0.106
E	0.90Typ		0.035Typ	
H	0.9	1.2	0.036	0.047
J	0.11	0.21	0.005	0.009

Mounting Pad Layout

SMA-FL

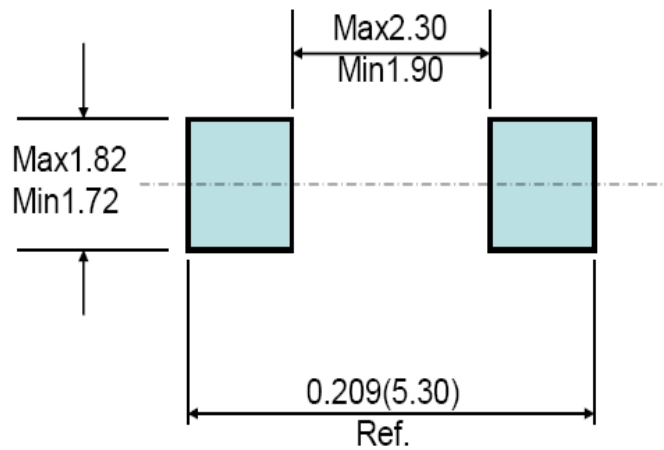

SM340AF: " S"--肖特基产品; M---贴片产品; "3"--正向电流3A; " 40"---VB为40V;AF---SMA-FL封装;

5.1 、 SMD Packing Reel Spec & Packing Quantity

5.1.1 Reel Packing
A. Reel Spec

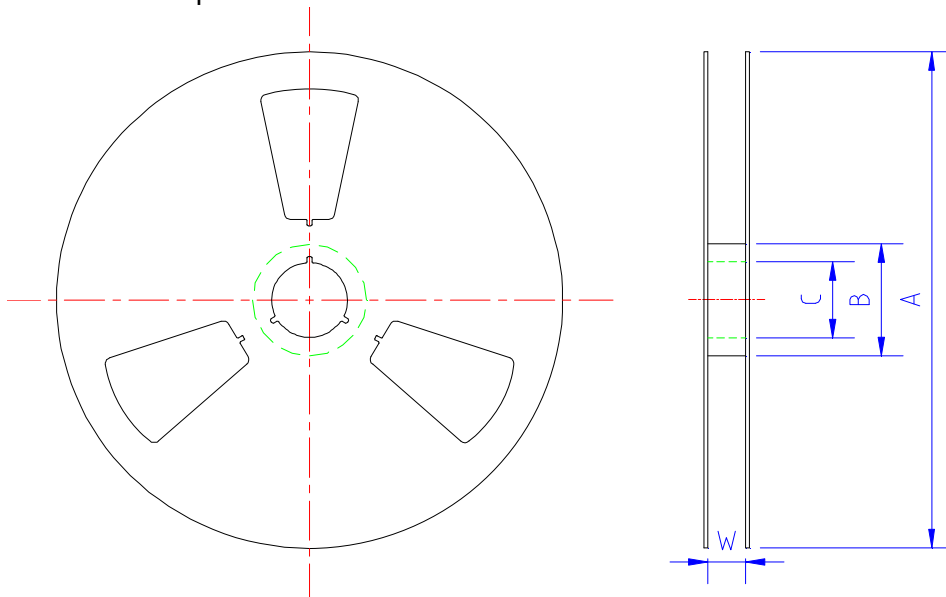

unit: mm

SPEC	A	B	C	W	Quantity/Reel
SMA-FL 7" reel	177.0±2.0	54.0±0.5	13.0±0.5	13.2±0.2	3K
TO277 13" reel	330.0±2.0	75.0±0.5	13.0±0.5	13.2±0.2	5K
SOD123FL 7" reel	177.0±2.0	50.0±0.5	13.0±0.5	9.4±1.5	3K
SOD323HE 7" reel	177.0±2.0	50.0±0.5	13.0±0.5	9.4±1.5	3K
SMB-FL 13" reel	330.0±2.0	75.0±0.5	13.0±0.5	13.2±0.2	5K

B. 13" reel packing box

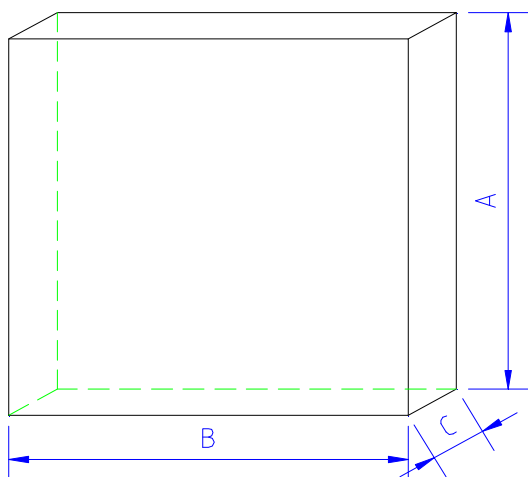

unit: mm

size	A	B	C
	335±5.0	335±2.0	40±1.0

as per above packing

Spec	Q' ty/Box
TO277 13" reel	10K
SMB-FL 13" reel	10K

Title:
Power Diode SMD Package Packing Spec

DOC NO.: WI-258

DOC NO.: WI-258

Page: 3

C. 7" reel packing box

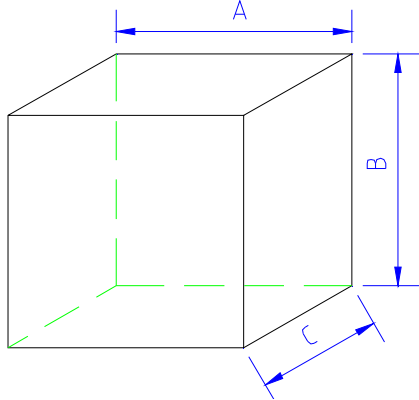

unit: mm

	A	B	C
SMA-FL			
SOD123FL			
SOD323HE	186±2.0	139±2.0	185±2.0

as per above packing

	Q' ty/Box
SMA-FL	30K
SOD123FL	30K
SOD323HE	30K

D. reel packing carton

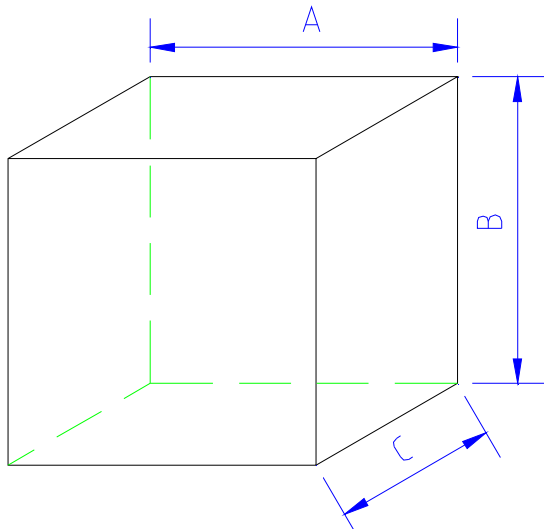

unit: mm

	A	B	C
size	350±2.0	340±2.0	350±2.0

as per above packing

Spec	Q' ty/Carton
TO277 13" reel	80K
SMB-FL 13" reel	80K

unit: mm

	A	B	C
SMA-FL			
SOD123FL			
SOD323HE	455±2.0	400±2.0	410±2.0

as per above packing

Spec	Q' ty/Carton
SMA-FL 7" reel	360K
SOD123-FL 7" reel	360K
SOD323HE 7" reel	360K

5.1.2 Tape Spec

A. Cover Tape



unit: mm

	A	B
SMA-FL	9.5±0.10	0.062±0.007
SMB-FL		
TO277		
SOD123FL	5.4±0.10	
SOD323HE		

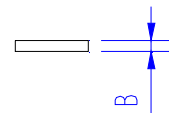

B. Carrier Tape

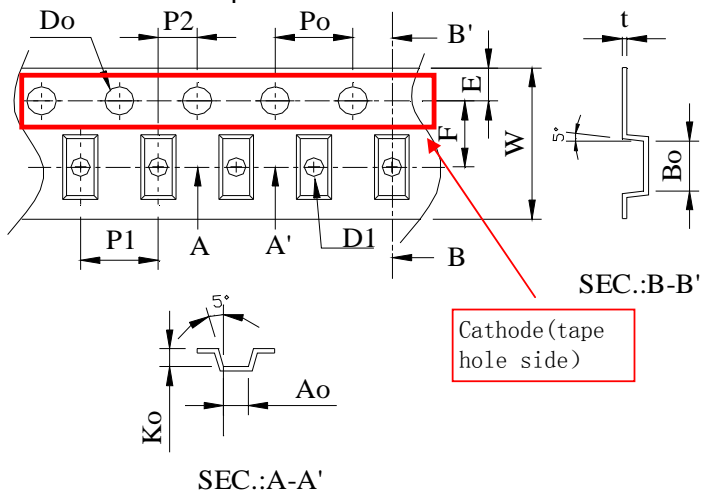

Item	SOD323HE	SOD123FL	SMA-FL	SMB-FL	TO277
W	8±0.3	8±0.3	12±0.3	12±0.3	12±0.3
P1	4±0.1	4±0.1	4±0.1	8±0.1	8±0.1
E	1.75±0.1	1.75±0.1	1.75±0.1	1.75±0.1	1.75±0.1
F	3.5±0.05	3.5±0.05	5.5±0.05	5.5±0.05	5.5±0.05
D0	1.55±0.05	1.55±0.05	1.55±0.05	1.55±0.05	1.55±0.05
D1	1.1±0.1	1.1±0.1	1.5±0.1	1.55±0.05	1.5±0.1
P0	4±0.1	4±0.1	4±0.1	4±0.1	4±0.1
P2	2±0.05	2±0.05	2±0.05	2±0.05	2±0.05
10P0	40±0.2	40±0.2	40±0.2	40±0.2	40±0.2
A0	1.45±0.1	1.95±0.1	2.83±0.1	3.8±0.1	4.3±0.1
B0	2.75±0.1	3.95±0.1	4.75±0.1	5.75±0.1	6.8±0.1
K0	0.80±0.1	1.30±0.1	1.42±0.1	1.4±0.1	1.35±0.1
T	0.25±0.05	0.25±0.05	0.25±0.05	0.25±0.05	0.25±0.05

5.2、SMD Power Diode General Packing Spec

A. 7" reel all labels will be at cathode side of reel ;

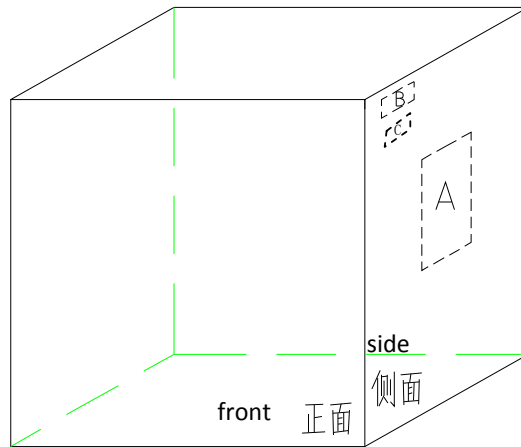
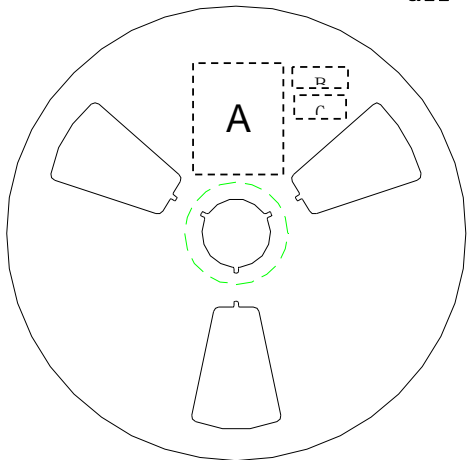

A:LRC label;

B:Environment Label C:Halide free label

B. 13" reel

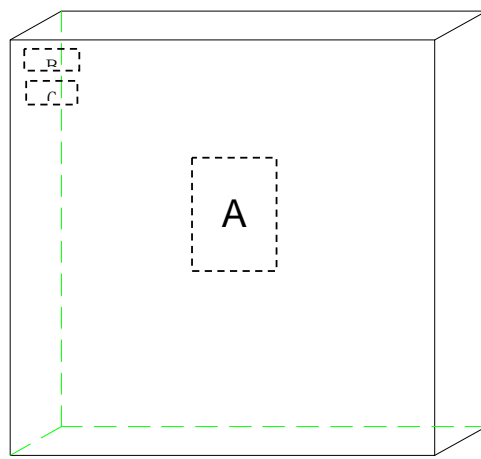
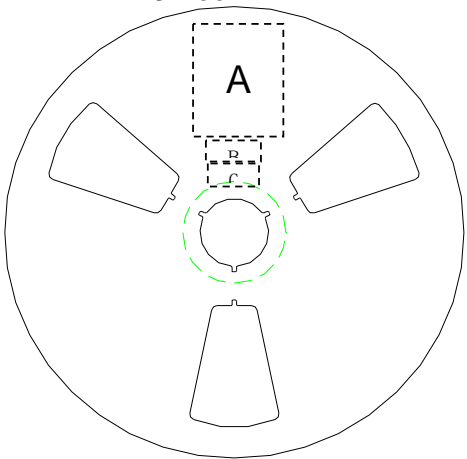

A:LRC label;

B:Environment Labe C:Halide free label

C. Tape lead: face anode side of the reel, upper side is the tape lead position. All labels are at cathode side of the reel.



→
User Direction of Feed

标题: Power Diode SMD Package Packing Spec	DOC NO.: WI-258
	Version: 5 Modification: 0
	Page: 6

C. Label Content :
LRC Label

P/N → (1P) LPN: **SM140A**
 Lot No. → (1T) LOT: **140106049X**
 Date code → (9D) DTE: **1403**
 Quantity → (Q) QTY: **10000**

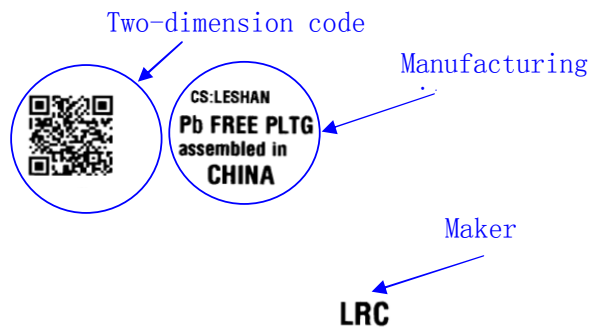

lot: 140106049X: 140106---2014/1/6; 049----lot number:49; X: product code

Environment Label



Halide-free Label



SM320AF thru SM3100AF

4. Update Record

版次	更新记录	更新作者	更新日期
1	第一版	周杰	2014. 04. 28
2	增加SB345AF	周杰	2014. 11. 06