

## Features

- +18 dBm Output Power
- -20 dBc Fundamental Leakage
- 3x3 mm QFN Package
- 100% RF, DC and Output Power Testing
- RoHS\* Compliant and 260°C Reflow Compatible

## Description

M/A-COM Tech's 7.5-22.5/15.0-45.0 GHz SMD active doubler delivers + 18 dBm of output power. The device combines an active doubler with an output buffer amplifier that delivers constant power over a range of input powers. The device has excellent rejection of the fundamental and harmonic products and requires a single positive bias supply. This device uses M/A-COM Tech's 0.15 GaAs pHEMT device model technology to ensure high reliability and uniformity. The device comes in a low-cost 3x3mm QFN Surface Mount Plastic Package offering excellent RF and thermal properties and is RoHS compliant. This device is well suited for Point-to-Point Radio, Microwave, LMDS, SATCOM and VSAT applications.

## Ordering Information

Part Number	Package
XX1000-QT-0G00	bulk quantity
XX1000-QT-0G0T	tape and reel
XX1000-QT-EV1	evaluation module

## Functional Block Diagram

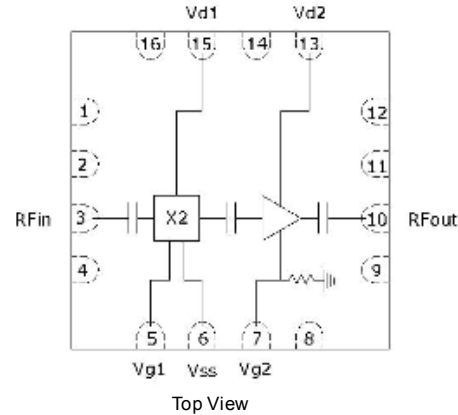

## Pin Configuration

Pin No.	Function	Pin No.	Function
3	RF In	13	VD2
5	VG1	15	VD1
6	VSS	2,4,9,11	Ground
7	VG2 <sup>1</sup>	1,8,12,14,16	Not Connected
10	RF Out		

1. VG2 can be used for current regulating VD2 or VG2 can be set to GND with VD2 self-biasing at approximately 140mA.

## Absolute Maximum Ratings

Parameter	Absolute Max.
Supply Voltage (Vd)	+6.0 VDC
Supply Voltage (Vss)	-6.0 VDC
Supply Current (Id)	300 mA
Supply Current (Iss)	60 mA
Gate Bias Voltage (Vg)	-0.4 VDC
Input Power (RF Pin)	+15.0 dBm
Storage Temperature (Tstg)	-65 °C to +165 °C
Operating Temperature (Ta)	-55 °C to MTTF Table <sup>1</sup>
Channel Temperature (Tch)	MTTF Table <sup>1</sup>

1. Channel temperature directly affects a device's MTTF. Channel temperature should be kept as low as possible to maximize lifetime.

# XX1000-QT



**Active Doubler**  
**7.5-22.5/15.0-45.0 GHz**

Rev. V1  
MimiX Broadband

## Electrical Specifications: 7.5-22.5 GHz Input Frequency (Ambient Temperature T=25°C)

Parameter	Units	Min.	Typ.	Max.
Output Frequency Range (fout)	GHz	15.0	-	45.0
Input Return Loss (S11)	dB	-	15.0	-
Output Return Loss (S22)	dB	-	7.0	-
Saturated Output Power (Psat)	dBm	-	+18	-
RF Input Power (RF Pin)	dBm	-10.0	-	+10.0
Fundamental Leakage (fin)	dBc	-	20	-
Third Harmonic Leakage (3xfin)	dBc	-	30	-
Fourth Harmonic Leakage (4xfin)	dBc	-	10	-
Drain Bias Voltage (Vd1,2)	VDC	-	+5.0	+5.5
Gate Bias Voltage (Vg1)	VDC	-0.8	-0.6	-0.4
Gate Bias Voltage (Vg2)	VDC	-1.2	0.0	+0.1
Supply Current (Id1,2) (Vd=5.0 V, Vg1=-0.6 V, Vg2=0.0 V Typical)	mA	-	220	250
Source Voltage (Vss)	VDC	-5.5	-5.0	-2.0
Source Current (Iss)	mA	25	50	60

# XX1000-QT

**Active Doubler**  
7.5-22.5/15.0-45.0 GHz

Rev. V1  
MimiX Broadband

## PCB Layout

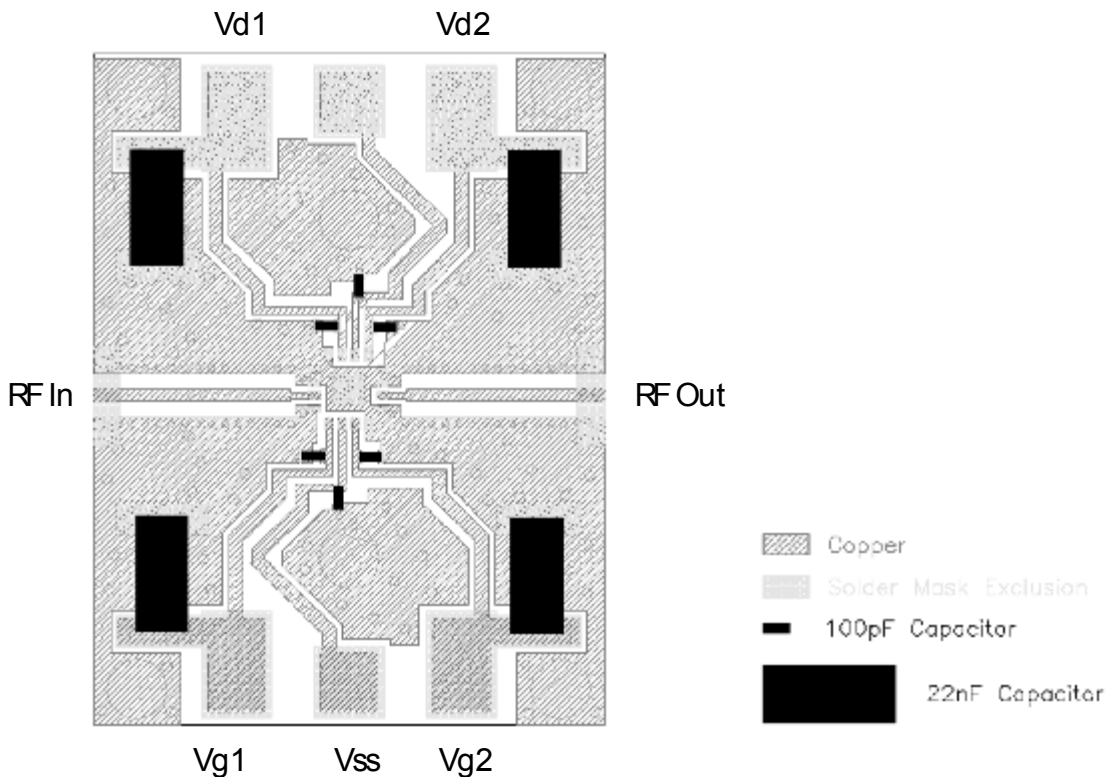

## Typical Performance Curves: Nominal Bias Conditions

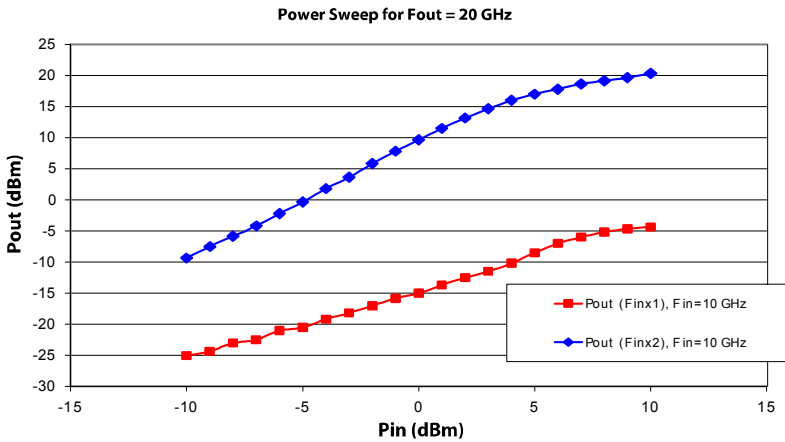
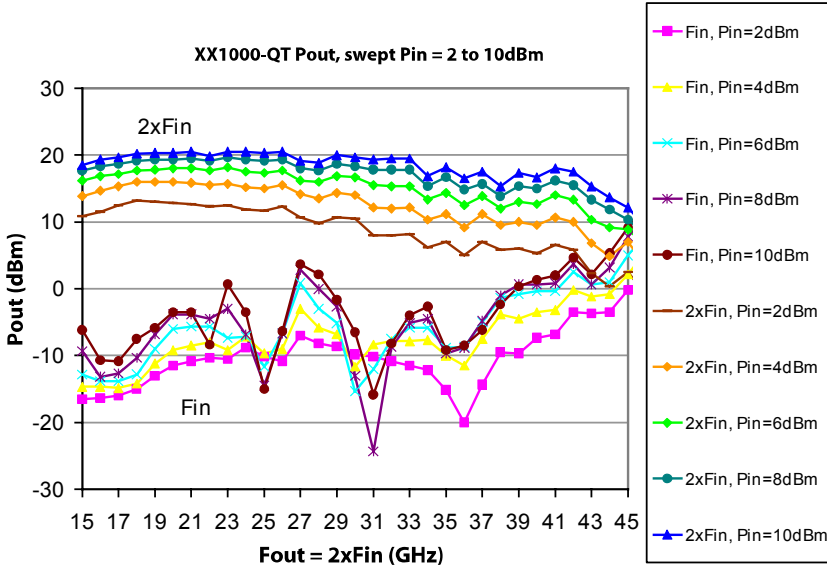

Measured results taken at room temperature in 40 GHz connectorized test fixture with no de-embedding.

## Typical Performance Curves (cont.)

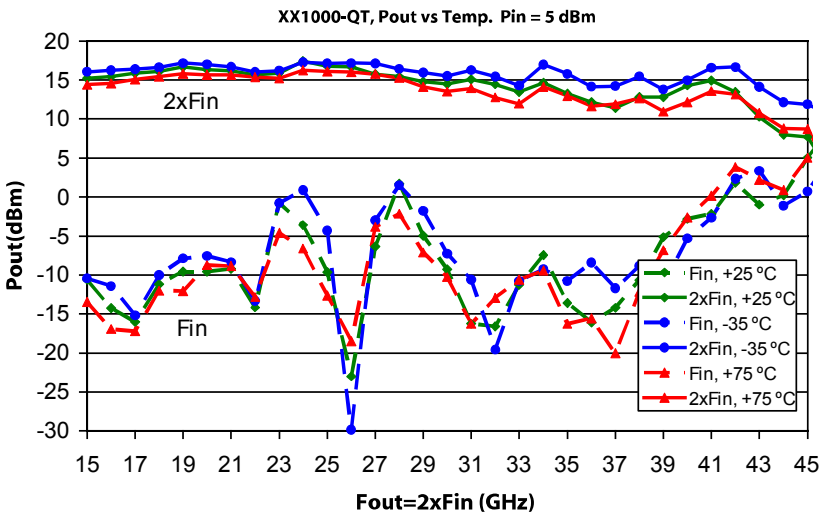
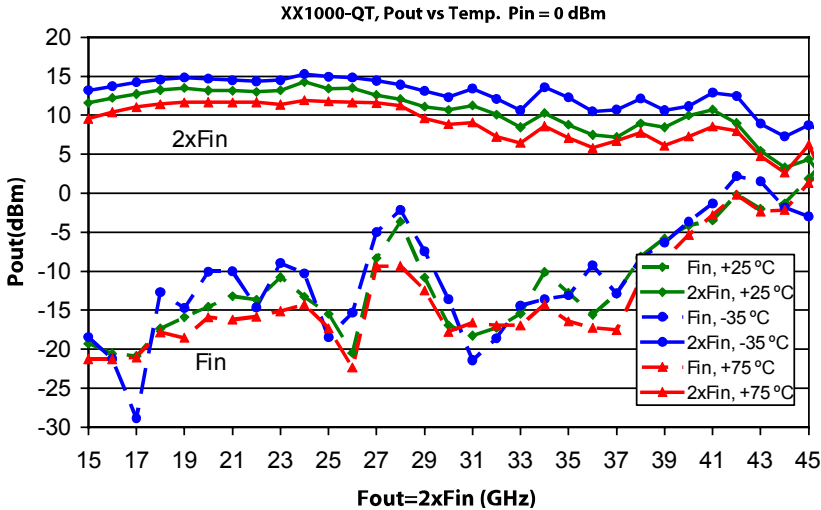

## Typical Performance Curves (cont.)

Harmonic Products, Pin = +5 dBm (Fin = 6 - 20 GHz)

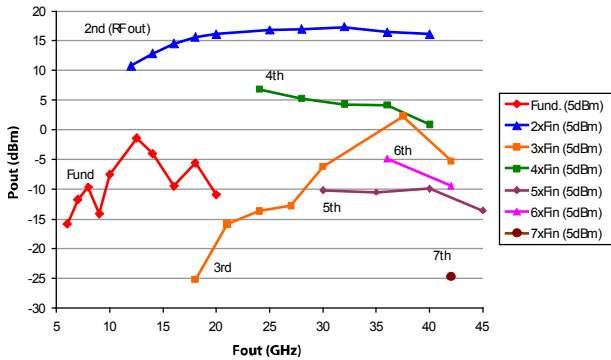

\* Measured on-wafer with pre-packaging.

Harmonic Products, Pin = +0 dBm (Fin = 6 - 20 GHz)

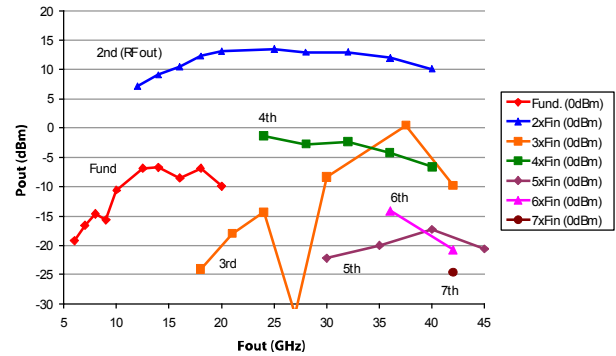

\* Measured on-wafer with pre-packaging.

XX1000-QT: Input Return Loss (dB)

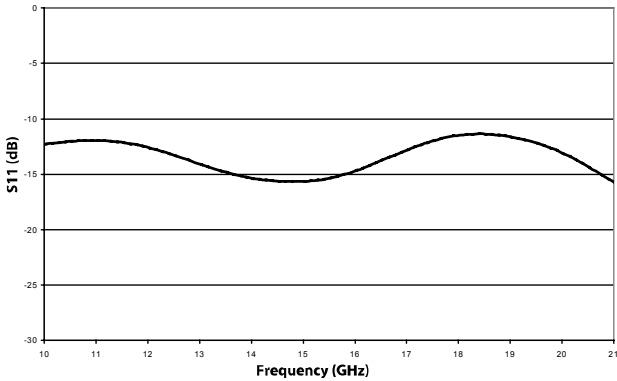

# XX1000-QT



Active Doubler  
7.5-22.5/15.0-45.0 GHz

Rev. V1  
MimiX Broadband

## MTTF

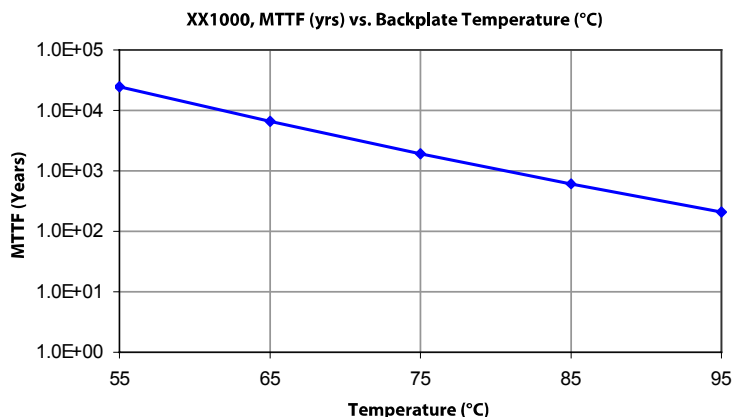

MTTF is calculated from accelerated life-time data of single devices and assumes isothermal back-plate.

Bias Conditions:  $V_{d1,2} = 5.0V$ ,  $I_{d1,2} = 220\text{ mA}$ ,  $V_{ss} = -5.0V$ ,  $I_{ss} = 50\text{ mA}$

**App Note [1] Biasing** - It is recommended to separately bias each doubler stage with fixed voltages of  $V_{d(1,2)} = 5.0V$ ,  $V_{ss} = -5.0V$  and  $V_{g1} = -0.6V$ . The typical DC currents are  $I_{d1} = 80mA$ ,  $I_{d2} = 140mA$  and  $I_{ss} = 50mA$ .  $V_{g2}$  can be used for active control biasing of  $V_{d2}$ , or it can be set to GND and  $V_{d2}$  will self bias at approximately 140mA. Maximum output power is achieved with  $V_{ss} = -5.0V$  and  $I_{ss} = 50mA$  but the device will operate with reduced bias to  $V_{ss} = -2.0V$  and  $I_{ss} = 25mA$ . It is also recommended to use active biasing on  $V_{d2}$  with  $V_{g2}$  to keep the currents constant as the RF power and temperature vary; this gives the most reproducible results. Depending on the supply voltage available and the power dissipation constraints, the bias circuit may be a single transistor or a low power operational amplifier, with a low value resistor in series with the drain supply used to sense the current. The gate of the pHEMT is controlled to maintain correct drain current and thus drain voltage. The typical gate voltage for  $V_{g2} = -0.1V$ . Typically the gate is protected with Silicon diodes to limit the applied voltage. Also, make sure to sequence the applied voltage to ensure negative gate bias is available before applying the positive drain supply.



## Lead-Free Package Dimensions/Layout

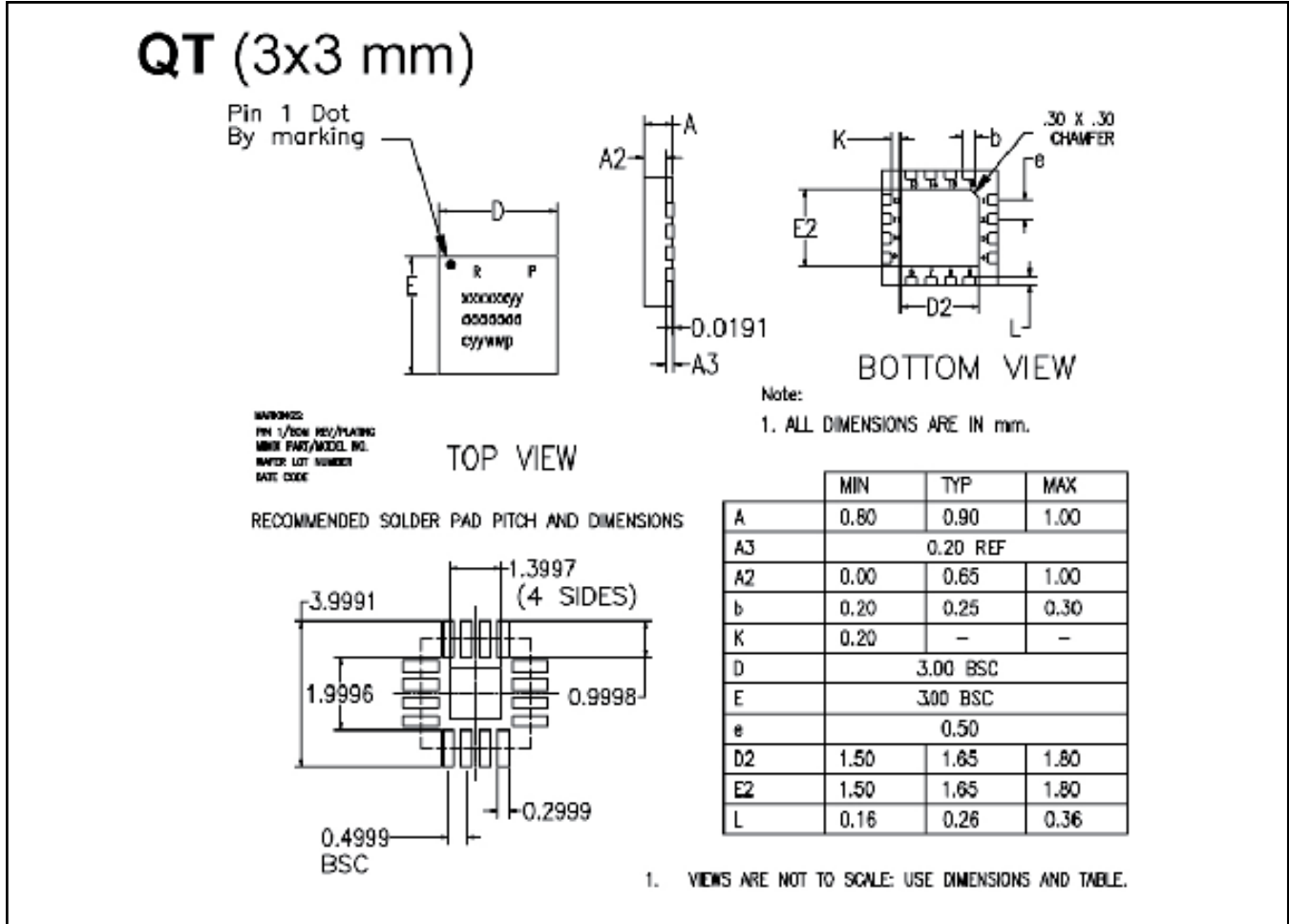

## Handling Procedures

Please observe the following precautions to avoid damage:

## Static Sensitivity

Gallium Arsenide Integrated Circuits are sensitive to electrostatic discharge (ESD) and can be damaged by static electricity. Proper ESD control techniques should be used when handling these class 2 devices.