

1.4MHz, 1A Synchronous Step-Down Converter

❖ GENERAL DESCRIPTION

AX3513A is a high efficiency monolithic synchronous buck regulator using a constant frequency, current mode architecture. The device is available in an adjustable version. Supply current with no load is 250uA and drops to <1uA in shutdown. The 2.5V to 5.5V input voltage range makes AX3513A ideally suited for single Li-Ion, two to three AA battery-powered applications. 100% duty cycle provides low dropout operation, extending battery life in portable systems. PWM operation provides very low output ripple voltage for noise sensitive applications. Switching frequency is internally set at 1.4MHz, allowing the use of small surface mount inductors and capacitors. The internal synchronous switch increases efficiency and decreases need of an external schottky diode. Low output voltages are easily supported with the 0.6V feedback reference voltage. AX3513A is available in small TSOT23-5L and TDFN-6L packages.

❖ FEATURES

- 2.5V to 5.5V Input Voltage Range
- Output Voltage from 0.6V to VIN
- High Efficiency: Up to 96%
- 1.4MHz Constant Frequency Operation
- Up to 1A Output Current
- Quiescent Current: 250uA (Typical)
- No Schottky Diode Required
- Current Mode Operation for Excellent Line and Load Transient Response
- Current limit, Enable function
- Short Circuit Protect (SCP)
- Build in soft start function
- $\leq 1\mu\text{A}$ Shutdown Current
- TSOT23-5L and TDFN-6L Pb-Free packages

❖ BLOCK DIAGRAM

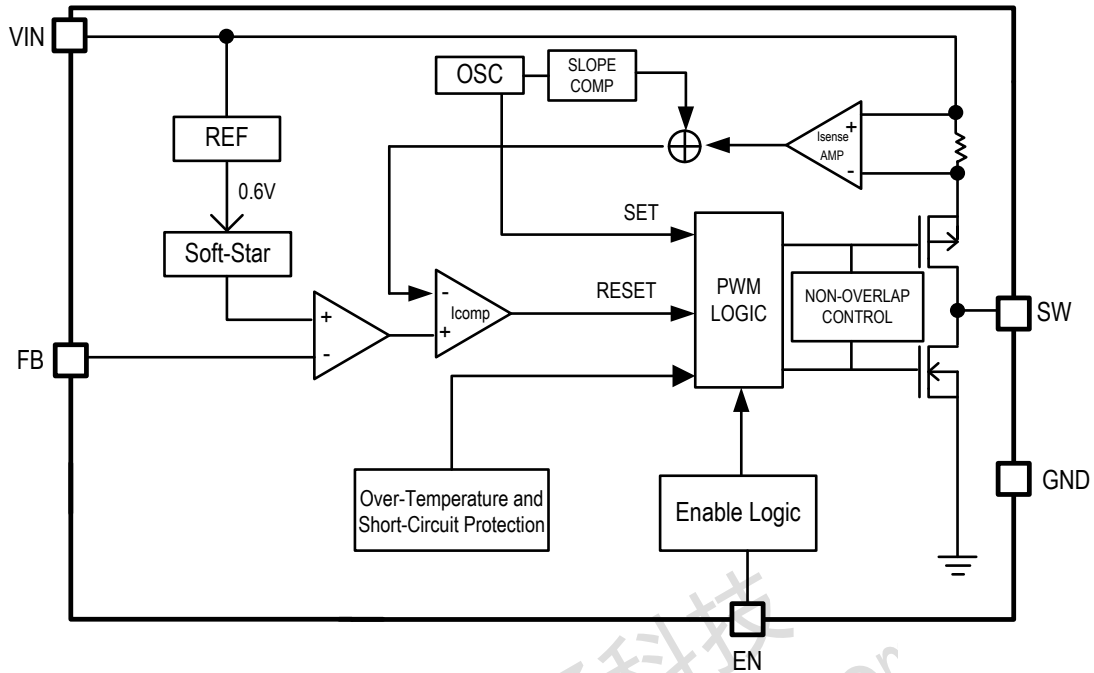

❖ PIN ASSIGNMENT

The packages of AX3513A are TSOT23-5L and TDFN-6L; the pin assignment is given by:

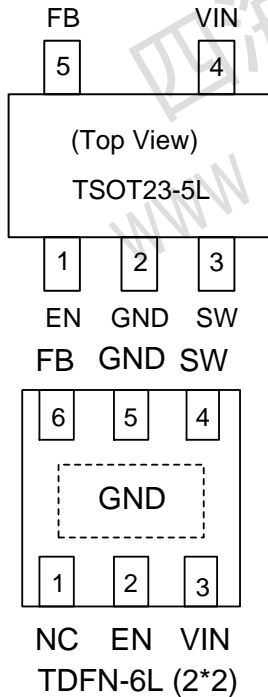

Name	Description
EN	Enable pin H : normal operation L : Shutdown
VIN	Power Supply Input Pin
SW	Switch output pin. Connect external inductor here. Minimize trace area at this pin to reduce EMI.
GND	Ground Pin
FB	Output Feedback pin
NC	No Connect.

❖ ORDER/MARKING INFORMATION

Order Information	
AX3513A X X X Package Type Packing BT: TSOT23-5L A : Taping Z6: TDFN-6L (2*2)	
Top Marking (TSOT23-5L)	Top Marking (TDFN-6L)
<p>GBYWX → ID code: internal WW: 01~26(A~Z) 27~52(a~z) Year: A=2010 1=2011</p>	<p>GB → AX3513A YWX → ID code: internal WW: 01~26(A~Z) 27~52(a~z) Year: A=2010 1=2011</p>

❖ ABSOLUTE MAXIMUM RATINGS (at T_A=25°C)

Characteristics	Symbol	Rating	Unit
VIN Pin Voltage	V _{IN}	V _{SS} - 0.3 to 6.5	V
Feedback Pin Voltage	V _{FB}	V _{SS} - 0.3 to V _{IN} +0.3	V
EN Pin Voltage	V _{EN}	V _{SS} - 0.3 to V _{IN} +0.3	V
Switch Pin Voltage	V _{SW}	V _{SS} - 0.3 to V _{IN} +0.3	V
Peak SW Sink and Source Current	I _{PSW}	1.4	A
Power Dissipation	PD	(T _J -T _A) / θ _{JA}	mW
Storage Temperature Range	T _{ST}	-40 to +150	°C
Operating Temperature Range	T _{OP}	-40 to +85	°C
Junction Temperature	T _J	+125	°C
Thermal Resistance from Junction to case	TDFN-6L	θ _{JC}	°C/W
	TSOT23		
Thermal Resistance from Junction to ambient	TDFN-6L	θ _{JA}	°C/W
	TSOT23		

Note: θ_{JA} is measured with the PCB copper area of approximately 1 in²(Multi-layer). That need connect to GND pin or exposed pad (AX3513AZ6).

❖ ELECTRICAL CHARACTERISTICS

($V_{IN} = V_{EN} = 3.6V$, $T_A = 25^\circ C$, unless otherwise specified)

Characteristics	Symbol	Conditions	Min	Typ	Max	Units
Input Voltage Range	V_{IN}		2.5	-	5.5	V
Feedback Voltage	V_{FB}	$T_A = +25^\circ C$	0.588	0.600	0.612	V
		$-40^\circ C \leq T_A \leq 85^\circ C$	0.582	0.600	0.618	
Feedback Bias Current	I_{FB}	$V_{FB} = 0.65V$	-	-	± 30	nA
Quiescent Current	I_{CCQ}	$V_{FB} = 1V$	-	250	350	μA
Shutdown Supply Current	I_{SD}	$V_{EN} = 0V$	-	0.1	1	μA
Switching Current Limit	I_{LIMIT}		1.2	1.4	-	A
Line Regulation	$\Delta V_{OUT}/V_{OUT}$	$V_{IN} = 2.5V$ to $5.5V$	-	0.04	0.4	%/V
Load Regulation	$\Delta V_{OUT}/V_{OUT}$	$I_{OUT} = 0.01$ to $1A$	-	0.5	-	%
Oscillation Frequency	F_{OSC}	SW pin	1.1	1.4	1.7	MHz
$R_{DS(ON)}$ of P-CH MOSFET	$R_{DS(ON)}$	$V_{FB} = 0V$, $I_{OUT} = 0.5A$	-	0.3	0.4	Ω
$R_{DS(ON)}$ of N-CH MOSFET	$R_{DS(ON)}$	(Note 1)	-	0.25	0.35	Ω
EN pin logic input threshold voltage	V_{ENL}		-	-	0.4	V
	V_{ENH}		1.5	-	-	
EN Pin Input Current	I_{EN}		-	± 0.1	± 1	μA
Efficiency	EFFI	$V_{IN} = 5V$, $V_{OUT} = 3.3V$, $I_{OUT} = 0.5A$	-	94	-	%
Thermal shutdown	T_{DS}		-	140	-	$^\circ C$
Thermal shutdown Hysteresis	T_{SH}		-	30	-	$^\circ C$

Note 1: Guaranteed by design.

❖ APPLICATION CIRCUIT

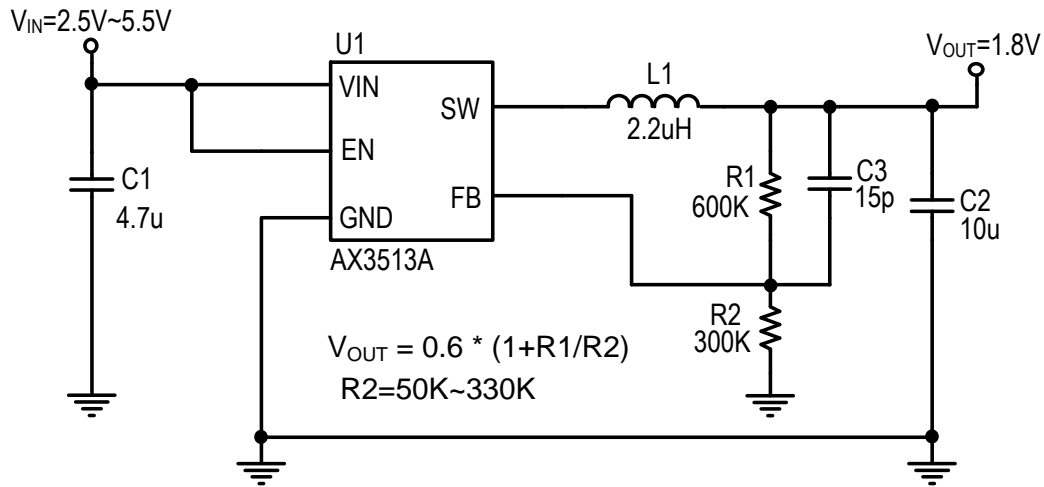

❖ FUNCTION DESCRIPTIONS

Operation

AX3513A is a monolithic switching mode step-down DC-DC converter. It utilizes internal MOSFETs to achieve high efficiency and can generate very low output voltage by using internal reference at 0.6V. It operates at a fixed switching frequency, and uses the slope compensated current mode architecture. This step-down DC-DC Converter supplies minimum 1000mA output current at input voltage range from 2.5V to 5.5V.

Current Mode PWM Control

Slope compensated current mode PWM control provides stable switching and cycle-by-cycle current limit for excellent load and line transient responses and protection of the internal main switch (P-Ch MOSFET) and synchronous rectifier (N-CH MOSFET). During normal operation, the internal P-Ch MOSFET is turned on for a certain time to ramp the inductor current at each rising edge of the internal oscillator, and switched off when the peak inductor current is above the error voltage. The current comparator, I_{COMP} , limits the peak inductor current. When the main switch is off, the synchronous rectifier will be turned on immediately and stay on until either the inductor current starts to reverse, beginning of the next clock cycle.

❖ **APPLICATION INFORMATION**

Setting the Output Voltage

Application circuit item shows the basic application circuit with AX3513A adjustable output version. The external resistor sets the output voltage according to the following equation:

$$V_{OUT} = 0.6V \times \left(1 + \frac{R1}{R2} \right)$$

Table 1 Resistor select for output voltage setting

V _{OUT}	R2	R1
1.2V	300K	300K
1.5V	300K	450K
1.8V	300K	600K
2.5V	150K	470K
3.3V	120K	540K

Inductor Selection

For most designs, the AX3513A operates with inductors of 2.2μH to 3.3μH. Low inductance values are physically smaller but require faster switching, which results in some efficiency loss. The inductor value can be derived from the following equation:

$$L = \frac{V_{OUT} \times (V_{IN} - V_{OUT})}{V_{IN} \times \Delta I_L \times f_{OSC}}$$

Where is inductor Ripple Current. Large value inductors lower ripple current and small value inductors result in high ripple currents. Choose inductor ripple current approximately 20% of the maximum load current 1000mA, Δ_L=200mA.

Table 2 Inductor select for output voltage setting (V_{IN} =3.6V)

V _{OUT}	1.2V	1.5V	1.8V	2.5V
Inductor	2.2uH	2.2uH	2.2uH	2.2uH
Part Number WE-TPC	7440430022	7440430022	7440430022	7440430022

Note: Part type MH or M (www.we-online.com)

For optimum voltage-positioning load transients, choose an inductor with DC series resistance in the 50mΩ to 150mΩ range. For higher efficiency at heavy loads (above 200mA), or minimal load regulation (but some transient overshoot), the resistance should be kept below 100mΩ. The DC current rating of the inductor should be at least equal to the maximum load current plus half the ripple current to prevent core saturation (1000mA+100mA).

Input Capacitor Selection

The input capacitor reduces the surge current drawn from the input and switching noise from the device. The input capacitor impedance at the switching frequency shall be less than input source impedance to prevent high frequency switching current passing to the input. A low ESR input capacitor sized for maximum RMS current must be used. Ceramic capacitors with X5R or X7R dielectrics are highly recommended because of their low ESR and small temperature coefficients. A 4.7μF ceramic capacitor for most applications is sufficient.

Output Capacitor Selection

The output capacitor is required to be 10uF to keep the output voltage ripple small and to ensure regulation loop stability. The output capacitor must have low impedance at the switching frequency. Ceramic capacitors with X5R or X7R dielectrics are recommended due to their low ESR and high ripple current.

Compensation Capacitor Selection

The compensation capacitors for increasing phase margin provide additional stability. It is required 15pF, Please refer to Demo Board Schematic to design.

❖ TYPICAL CHARACTERISTICS

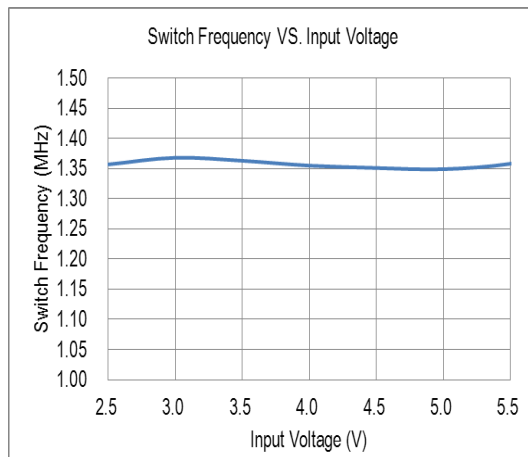
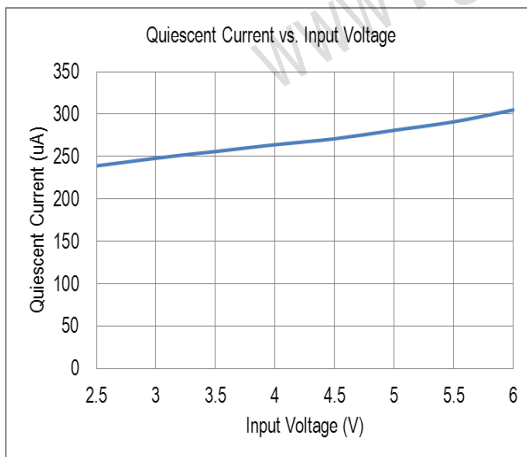
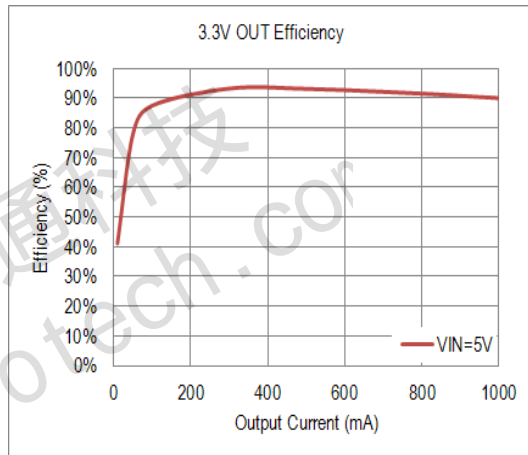
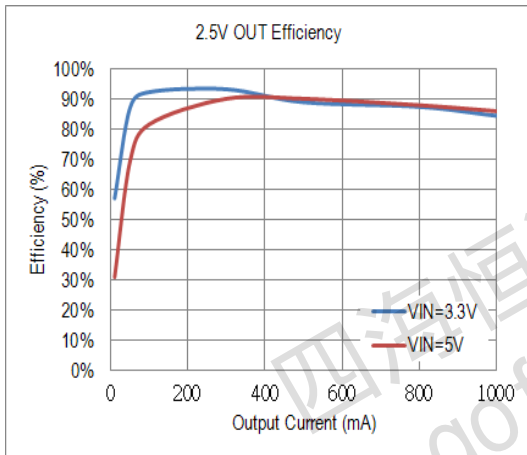
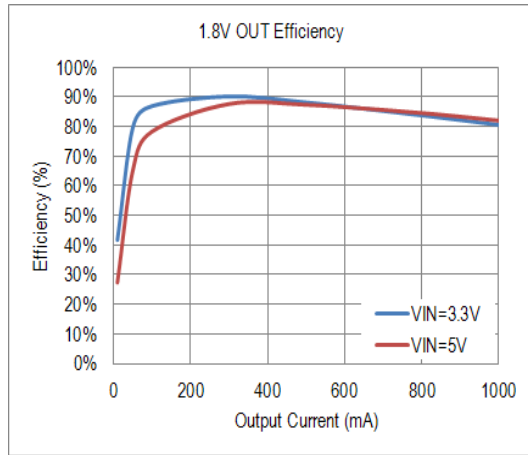
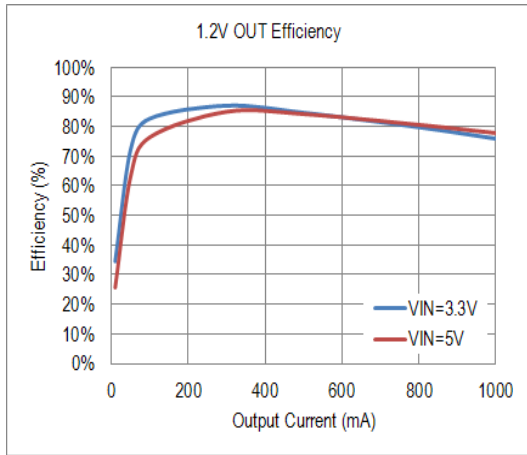

❖ TYPICAL CHARACTERISTICS (CONTINUES)

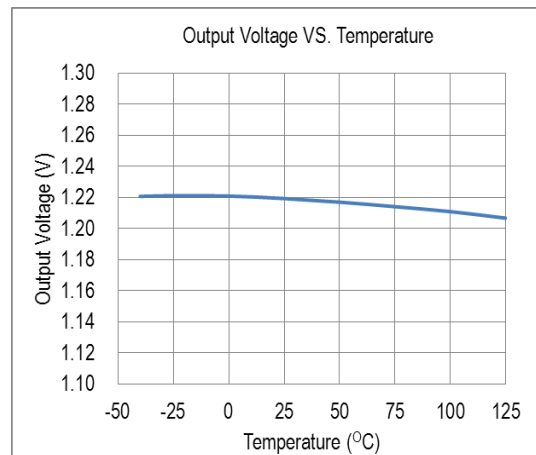
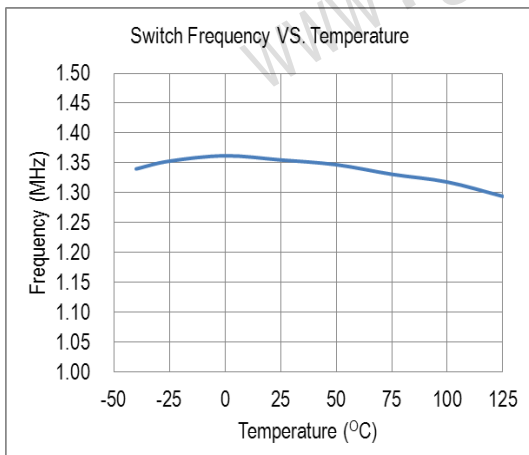
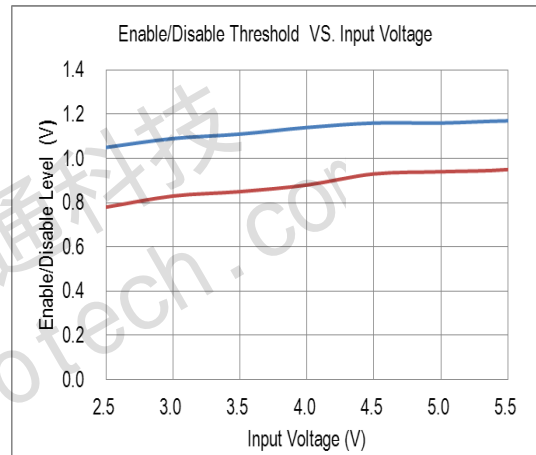
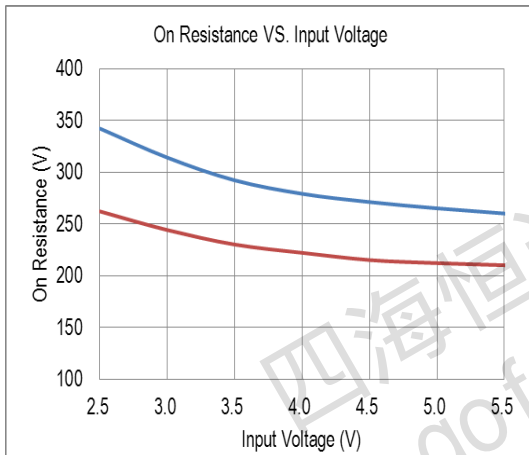
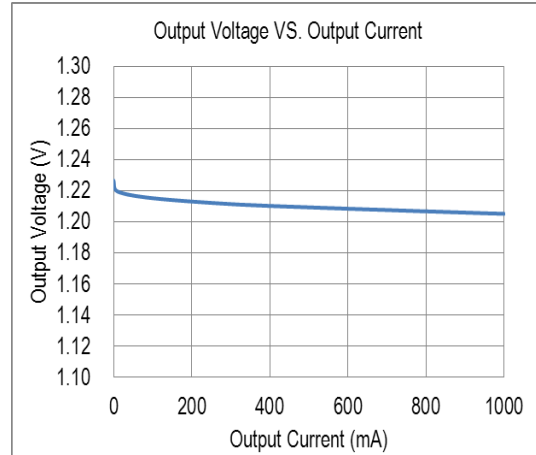
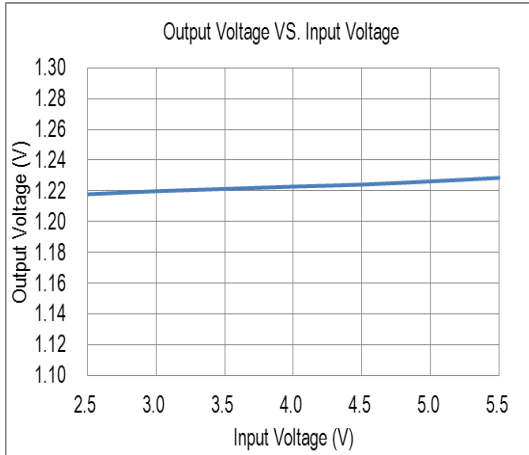

❖ TYPICAL CHARACTERISTICS (CONTINUES)

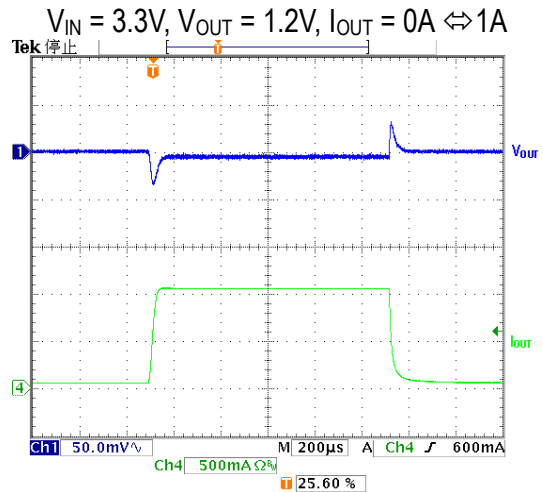
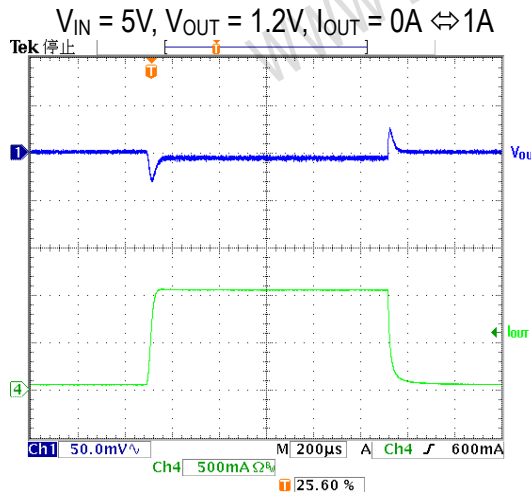
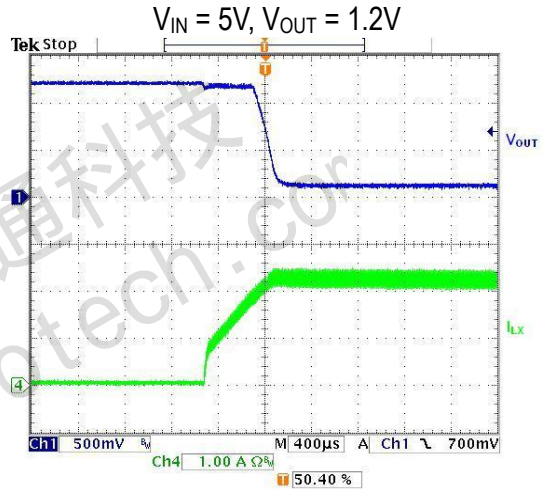
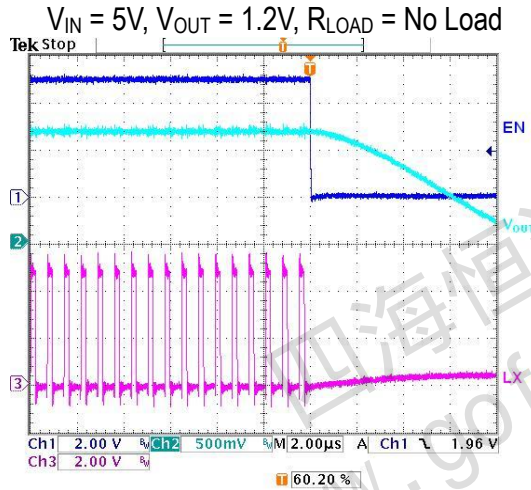
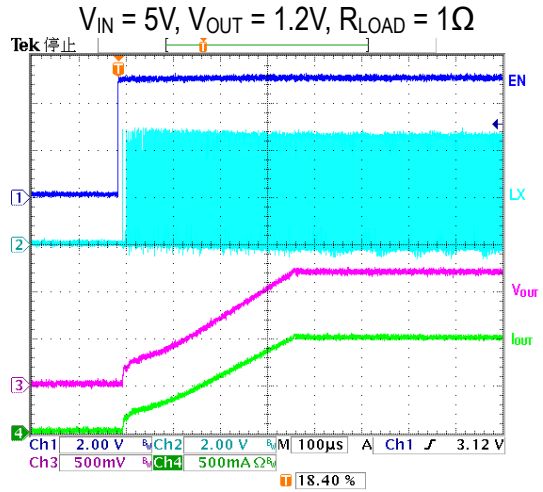
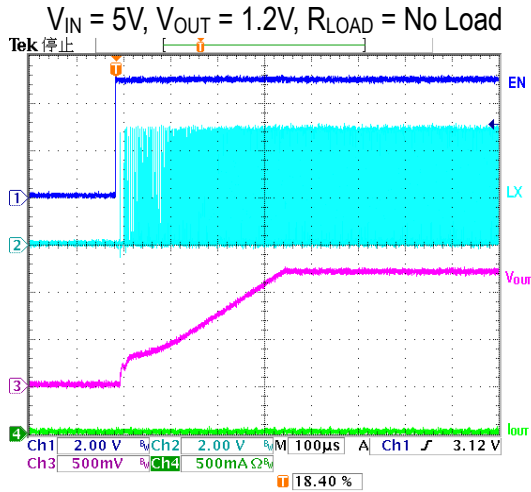

❖ PACKAGE OUTLINES

(1) TSOT23-5L

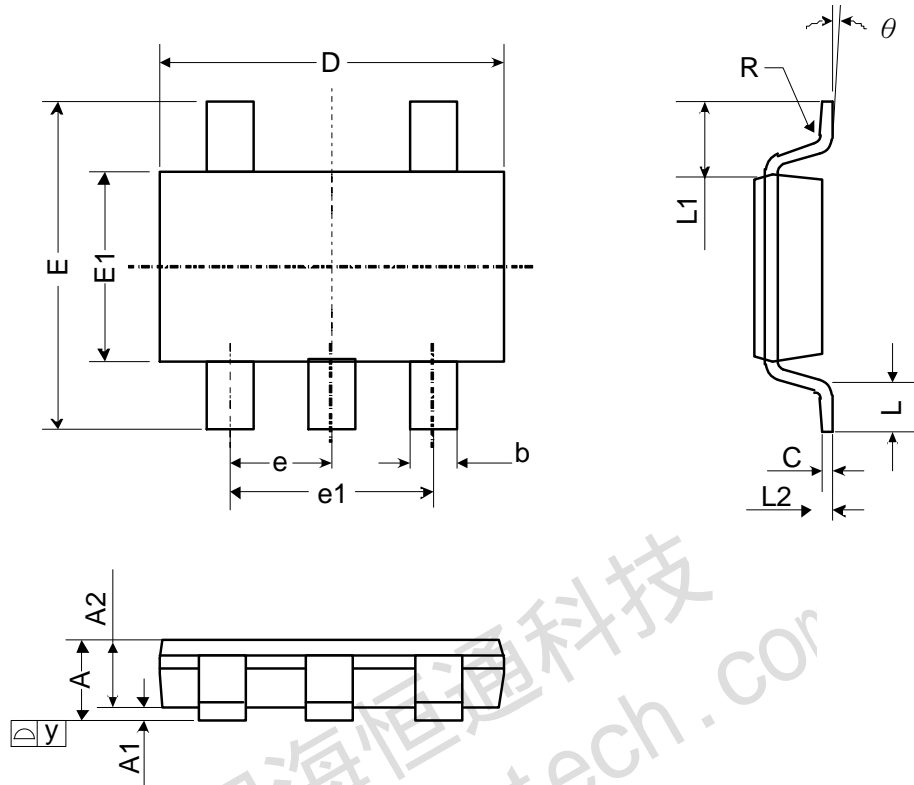

Symbol	Dimensions in Millimeters			Dimensions in Inches		
	Min.	Nom.	Max.	Min.	Nom.	Max.
A	-	-	1.1	-	-	0.043
A1	0	-	0.1	0	-	0.004
A2	0.7	0.9	1	0.028	0.035	0.039
b	0.3	0.4	0.5	0.012	0.016	0.02
C	0.08	0.14	0.2	0.003	0.006	0.008
D	2.8	2.9	3	0.11	0.114	0.118
E	2.6	2.8	3	0.102	0.11	0.118
E1	1.5	1.6	1.7	0.059	0.063	0.067
e	0.95 BSC.			0.037 BSC.		
e1	1.90 BSC.			0.075 BSC.		
L	0.3	0.45	0.6	0.012	0.018	0.024
L1	0.60 REF.			0.024 REF.		
L2	0.25 BSC.			0.010 BSC.		
y	-	-	0.1	-	-	0.004
R	0.1	-	-	0.004	-	-
θ	0°	-	8°	0°	-	8°

JECED outline: MO-193 AB

(2) TDFN-6L (2*2 0.75mm)

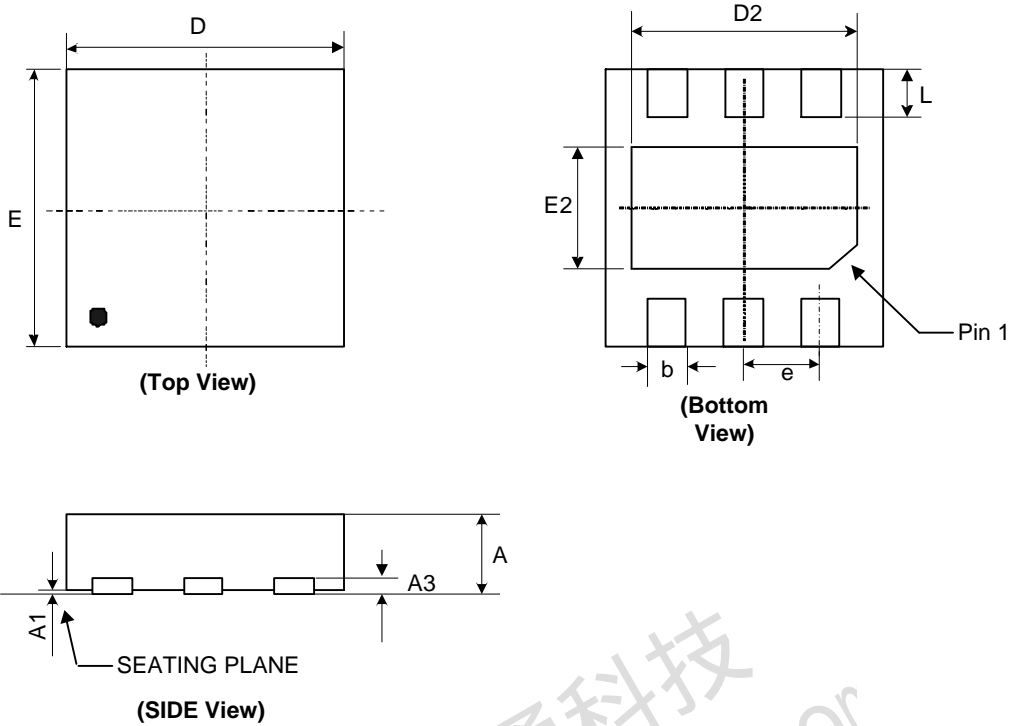

Symbol	Dimensions in Millimeters			Dimensions in Inches		
	Min.	Nom.	Max.	Min.	Nom.	Max.
A	0.7	0.75	0.8	0.028	0.03	0.031
A1	0	0.02	0.05	0	0.001	0.002
A3	0.203 REF.			0.008 REF.		
b	0.2	0.28	0.35	0.009	0.011	0.013
D	1.95	2	2.05	0.077	0.079	0.081
D2	1.35	1.5	1.65	0.055	0.059	0.063
E	1.95	2	2.05	0.077	0.079	0.081
E2	0.75	0.9	1.05	0.031	0.035	0.039
e	0.65 BSC.			0.026 BSC.		
L	0.2	0.3	0.4	0.008	0.012	0.016