

Product Features

- On-chip analog functions for rechargeable battery charge/discharge management.
- Constant and pulse current charging operations
- Fast charge detection by: $-\Delta V$, $0\Delta V$,
- Charge protection with safety timer 90 minutes, maximum voltage, maximum temperature.
- On-chip voltage reference and regulator.
- On-chip high precision 5-bits ADC.
- Cord existence detection and indicator
- Low Battery detection and indicator
- Few external components needed

Product Description

PT8A2703 is designed as a mixed signal device to provide a single chip solution for rechargeable battery powered smart controllers using only a few external components such as transistors, passive components and LED. The chip handles charging with fast constant or pulse current charging modes and discharging. It contains enough logic circuits on chip to implement custom applications such as clipper, hair remover, high-end toy/aeromodelling and other portable devices.

Ordering Information

Part Number	Package
PT8A2703DE D	Die Form
PT8A2703W 16-	Pin SOIC
PT8A2703WE 16-	Pin SOIC
PT8A2713S 20-	Pin SOIC

Block Diagram

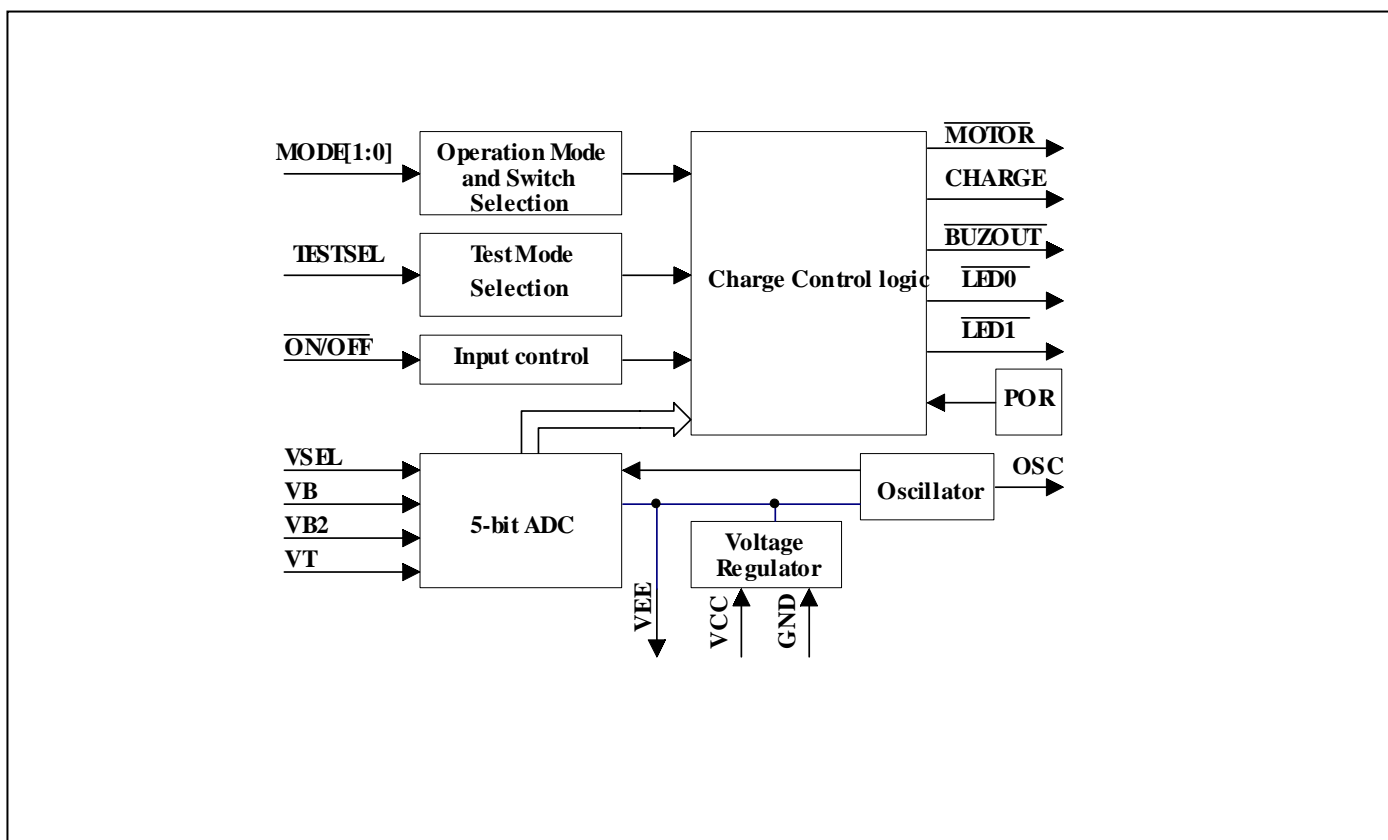

Pin assignment

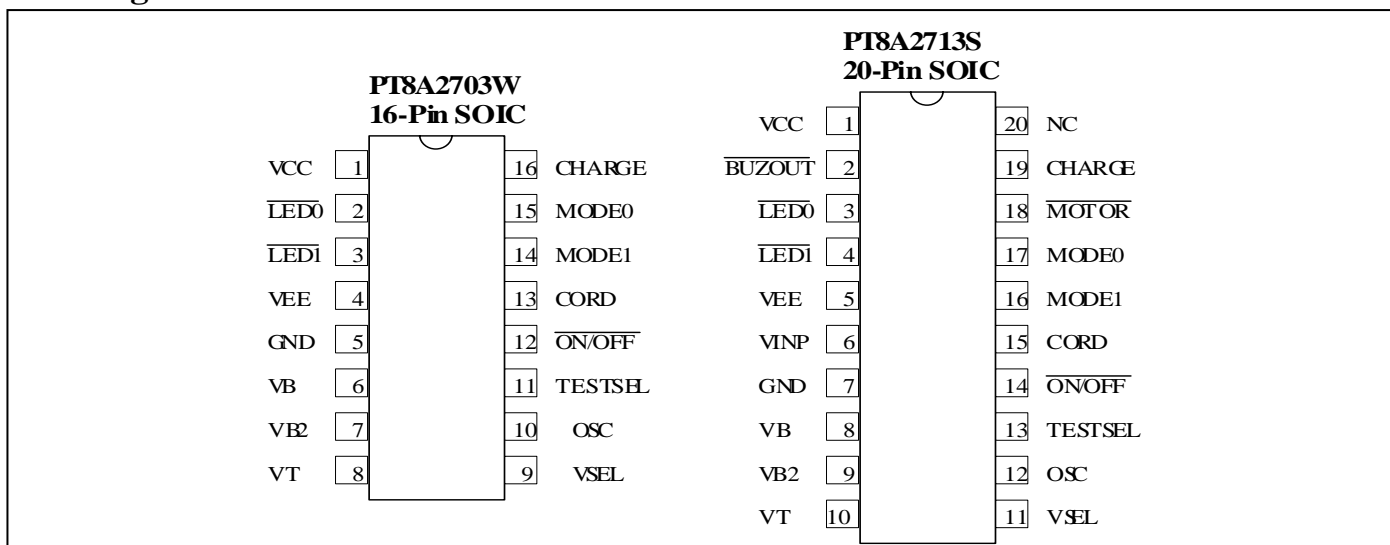

Pad Location

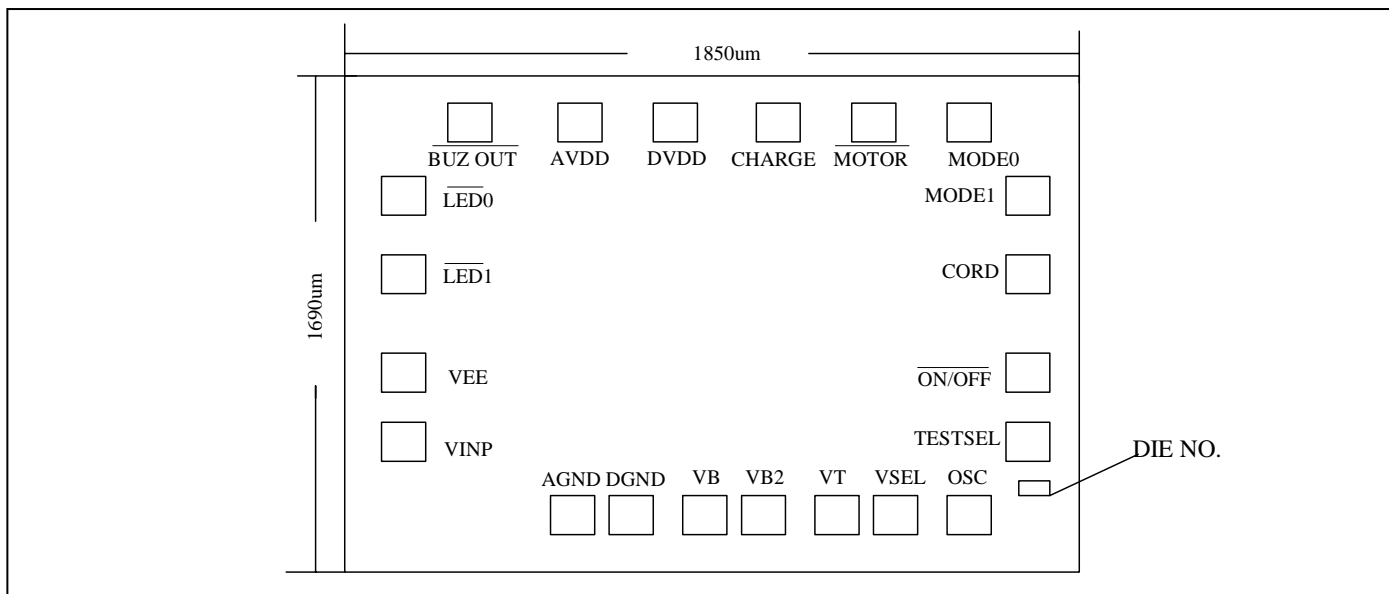

Pad Coordinates

Pad Name	X Coordinate	Y Coordinate	Pad Name	X Coordinate	Y Coordinate
DVDD	808.5	1534.45	VT	1081.85	166.05
AVDD	520.1	1534.45	VSEL	1185.75	166.05
BUZOUT	264.7	1534.45	OSC	1351.15	166.05
LED0	155.4	1298.3	TESTSEL	1688.05	478.35
LED1	155.4	1038.7	ON/OFF	1688.05	733.75
VEE	155.4	750.3	CORD	1688.05	1022.15
VINP	155.35	395.1	MODE1	1688.05	1277.55
AGND	560.05	166.05	MODE0	1607.7	1534.45
DGND	663.95	166.05	MOTOR	1352.3	1534.45
VB	820.95	166.05	CHARGE	1063.9	1534.45
VB2	924.85	166.05			

Note: Substrate is connected to GND

Pad/Pin Description

Pin #	Pin/Pad Name	I/O	Pad/Pin Descriptions
2703W 2713S			
1 1	VCC(DVDD,AVDD)	-	Positive supply voltage from battery
-	2 BUZOUT	O	Buzzer output, active low.
2 3	LED0	O	Low battery indicator LED output, active low.
3 4	LED1	O	Corded Mode/Charging indicator LED output, active low.
4 5	VEE	O	Internal regulator output (about 2.0V)
- 6	VINP	I	Positive input terminal of regulator opamp
5 7	GND (AGND,DGND)	-	Power ground
6 8	VB	I	Divided input of Battery voltage (range from 1.6V to 1.8V)
7 9	VB2	I	Low battery voltage detection channel (range from 1.6V to 1.8V)
8 10	VT	I	Battery temperature NTC voltage (range from 1.6V to 1.8V)
9 11	VSEL	I	Zero/negative delta voltage duration selection <0.825VEE : 3min (NiCd)/ 10min (NiMH) <0.850VEE and >0.825VEE: 1min (NiCd)/ 6min (NiMH) <0.875VEE and >0.850VEE: 2min (NiCd)/ 8min (NiMH) >0.875VEE: 4min (NiCd)/ 12min (NiMH)
10 12	OSC	I	Connected to an RC network for the internal system clock, 64kHz
11 13	TESTSEL	I	Test mode select, internal pull up.
12 14	ON/OFF	I	Motor On/Off key
13 15	CORD	I	External cord detection (digital level), , active high
14 16	MODE1	I	0 : zero delta voltage detection; 1 : negative delta voltage detection
15 17	MODE0	I	0 : Tact switch; 1 : Slide switch mode
- 18	MOTOR	O	Drive motor switch enable (active low)
16 19	CHARGE	O	Battery charge control signal to drive NPN switch for charging
- 20	NC -		No connection

Notes : All LED signals are active low with negative pulse trains

Functional Description

5-bit ADC: On-chip high precision 5-bit ADC to sample the data of Battery voltage and temperature.

Voltage Regulator (2.0V Regulator): Build-in voltage regulator used to power supply RC oscillator and 5-bit ADC.

Oscillator: Internal RC oscillator to generate a 64KHz system oscillator.

POR: Power on reset to reset all internal logic

Operation Mode and Switch selection

Operation Mode selection to select different fast charging detection methods by setting MODE1, including 0ΔV detection and -ΔV detection approach. S witch selection to select t he usage of tact or slide s witch b y setti ng MO DE0. T able 2 is th e relationship between operation mode and fast charging detection method as well as relationship between MODE0 and switch type

Table 2

MODE1	Fast charging detection method	MODE0	Switch type
0	0ΔV detection	0 T	act switch
1	-ΔV detection	1 slid	e switch

Switch operation with $\overline{\text{ON/OFF}}$

$\overline{\text{ON/OFF}}$ is a Tact S witch or Slide S witch input. $\overline{\text{ON/OFF}}$ acts as active high input for slide switch and active low for tact switch. For 2703, only slide switch mode is supported.

LED display

The $\overline{\text{LED1}}$ indicates corded mode/charging . The $\overline{\text{LED0}}$ indicates low battery voltage.

Charging and Motor control

Cord Mode and Motor off

Constant Current Charging and Motor off

Before full charged, battery will be fast charged with 1C constant current, The $\overline{\text{LED1}}$ always lights during this period.

Pulse Current Charging and Motor off

Once battery voltage experiences zero delta V or n egative delta V according to the selection of fast charging detection approach, The $\overline{\text{LED1}}$ indicator flashes at the frequency of 1Hz (0.5s ON, 0.5s OFF). At the same time, Charging operation transfers to pulse Current Charging.

Battery charge operation will drop to pulse current charging if the temperature of battery exceeds preset temperature by VT pin. The $\overline{\text{LED1}}$ indicator flashes at a frequency of 1Hz (0.5 s ON, 0.5 s OFF).

During pulse current charging, charge pulses output at charge pin run about at the rate of 12.5Hz with duty cycle of 10%.

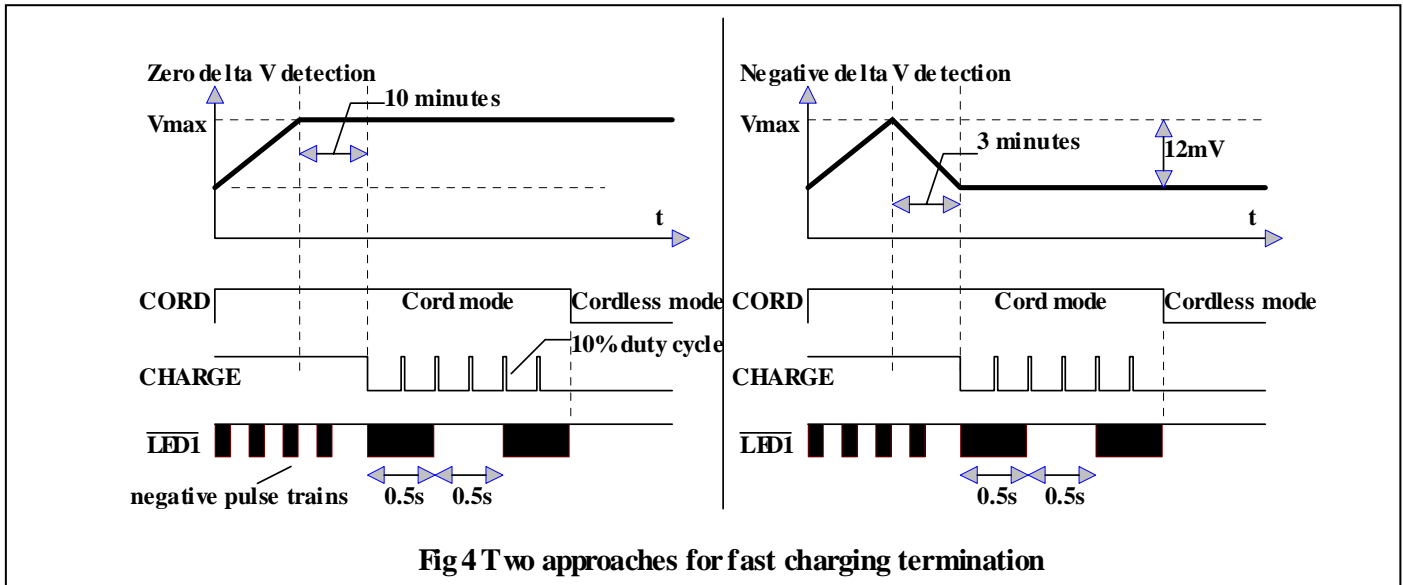

Temperature to terminate charging: Charging stops immediately if the temperature of the battery exceeds the maximum preset temperature value. Pulse charging continues when temperature drops below a lower preset temperature value. Once over-temperature condition, the two led indicators turn off right away.

Cord Mode and Motor on

When $\overline{\text{ON/OFF}}$ is triggered to turn on the Motor during Cord Mode, $\overline{\text{MOTOR}}$ output low to drive Motor.

When $\overline{\text{ON/OFF}}$ is triggered to turn off the Motor during Cord Mode, Shaver switches immediately to “Charging operation”.

When CORD removed during Corded Mode, Shaver switches to “Cordless Mode” operation.

The $\overline{\text{LED1}}$ indicator is always on during Cord Mode. The $\overline{\text{LED0}}$ indicator is on if Battery voltage is lower than a preset voltage value at VB2 pin. In contrary, the $\overline{\text{LED0}}$ indicator is off if Battery voltage is normal.

Cordless Mode and Motor on or off

When CORD is removed (Cordless Mode) and Motor off, the $\overline{\text{LED1}}$ indicator is off immediately. The $\overline{\text{LED0}}$ indicator is on for 7 seconds if Battery voltage is over low. In contrary, the $\overline{\text{LED0}}$ indicator is off if Battery voltage is normal.

Once motor on during Cordless Mode, the $\overline{\text{LED1}}$ indicator is off.

If motor off during Cordless Mode, the $\overline{\text{LED0}}$ indicator is on for 7 seconds if Battery voltage is over low. In contrary, the $\overline{\text{LED0}}$ indicator is off if Battery voltage is normal.

Low Battery

If Battery voltage is below or equal a preset voltage value at the VB2, the $\overline{\text{LED0}}$ indicator is on to show low battery, the Motor will turn off. In contrary, the $\overline{\text{LED0}}$ indicator is off if Battery voltage is normal.

Maximum Ratings

Storage Temperature.....	-25°C to +85°C
Ambient Temperature with Power Applied	0°C ~70°C
Supply Voltage to Ground Potential (Inputs & V _{CC} Only).....	0.5V to V _{CC} +0.5V
DC Input Voltage.....	0.5V to V _{CC} +0.5V
DC Output Current.....	20mA
Power Dissipation.....	500mW

Note:

Stresses greater than those listed under MAXIMUM RATINGS may cause permanent damage to the device. This is a stress rating only and functional operation of the device at these or any other conditions above those indicated in the operational sections of this specification is not implied. Exposure to absolute maximum rating conditions for extended periods may affect reliability.

Die Handling Recommendation

1. Assembly process under 10k class cleanroom, environmental control is important.
2. Regular cleaning of pick & place vacuum cups to prevent die scratch.
3. Select the most suitable encapsulant for die coverage. Encapsulant can affect the device performance. Characterization and pilot production are highly recommended.
4. ESD environment control and esd-safe materials in all equipment, especially die bonder and wire bonder. For example, esd-safe vacuum cups used in die bonder.
5. Failure analysis cannot be performed for die sale material and very limited investigation on process traceability.

Recommendation operation condition.

Parameters Description	Min.	Typ.	Max.	Unit
V _{CC}	2.2	2.4	3.0	V
V _{in}	0.8	-	0.9	VEE
F _{osc}	58.88	64	69.12	kHz
T _A Operation	0	25	70	°C

DC Electrical Characteristics (T_A= 0~70°C, V_{CC}= 2.4V unless otherwise claims)

Regulator

Symbol Parameter	Test Condition	Min.	Typ.	Max.	Unit	
						V _{CC}
VEE	Regulator Output Voltage	2.4V	No load	1.90	2.1	V
ΔV _O	Line regulation	-	2.2 ≤ V _{CC} ≤ 3.0V, No load	-	- 50	mV
ΔV _{LDR}	Load regulation	2.4V	0mA ≤ I _L ≤ 3mA	-	- 50	mV

5-bit ADC

Symbol Parameter	Test Condition	Min.	Typ.	Max.	Unit		
						V _{CC}	Condition
Average result	A/D resolution	2.4V	No load	5.5	6.25	7.0	mV
DNL	Differential Nonlinearity	2.4V	No load	-	1	-	LSB
INL	Integral Nonlinearity	2.4V	No load	-	1	-	LSB

Symbol	Description	Test Conditions	Min.	Typ.	Max.	Unit
I _{CC S}	Supply Current	V _{CC} =2.4V, R=47K, C=390pf, no load	-	-	1	mA
I _{IL}	Input Low leakage Current	V _{CC} =2.4V, V _{IL} =0.2V, (C _{ORD} , MODE[1..0], ON/OFF)	-1	-	1	uA
I _{IH}	Input High leakage Current	V _{CC} =2.4V, V _{IL} =2.2V (C _{ORD} , MODE[1..0], ON/OFF)	-1	-	1	uA
I _{OH}	Output High Current	LED[1:0]	-30	-	-	uA
		CHARGE -2		-	-	mA
		MOTOR	-0.5	-	-	mA
I _{OL}	Output Low Current	LED[1:0]	5	-	-	mA
		CHARGE 2		-	-	mA
		MOTOR	10	-	-	mA

AC Electrical Characteristics (T_A= 0~70°C, V_{CC}= 2.2V~3.0V)

Symbol	Description	Test Conditions	Min.	Typ.	Max.	Unit
F _{OSC}	Oscillator Frequency	C=390pf, R=47kohm	58.88	64	69.12	KHz

Typical Application Circuit

Slide Switch Mode(Zero Delta Voltage Detection) of 2703

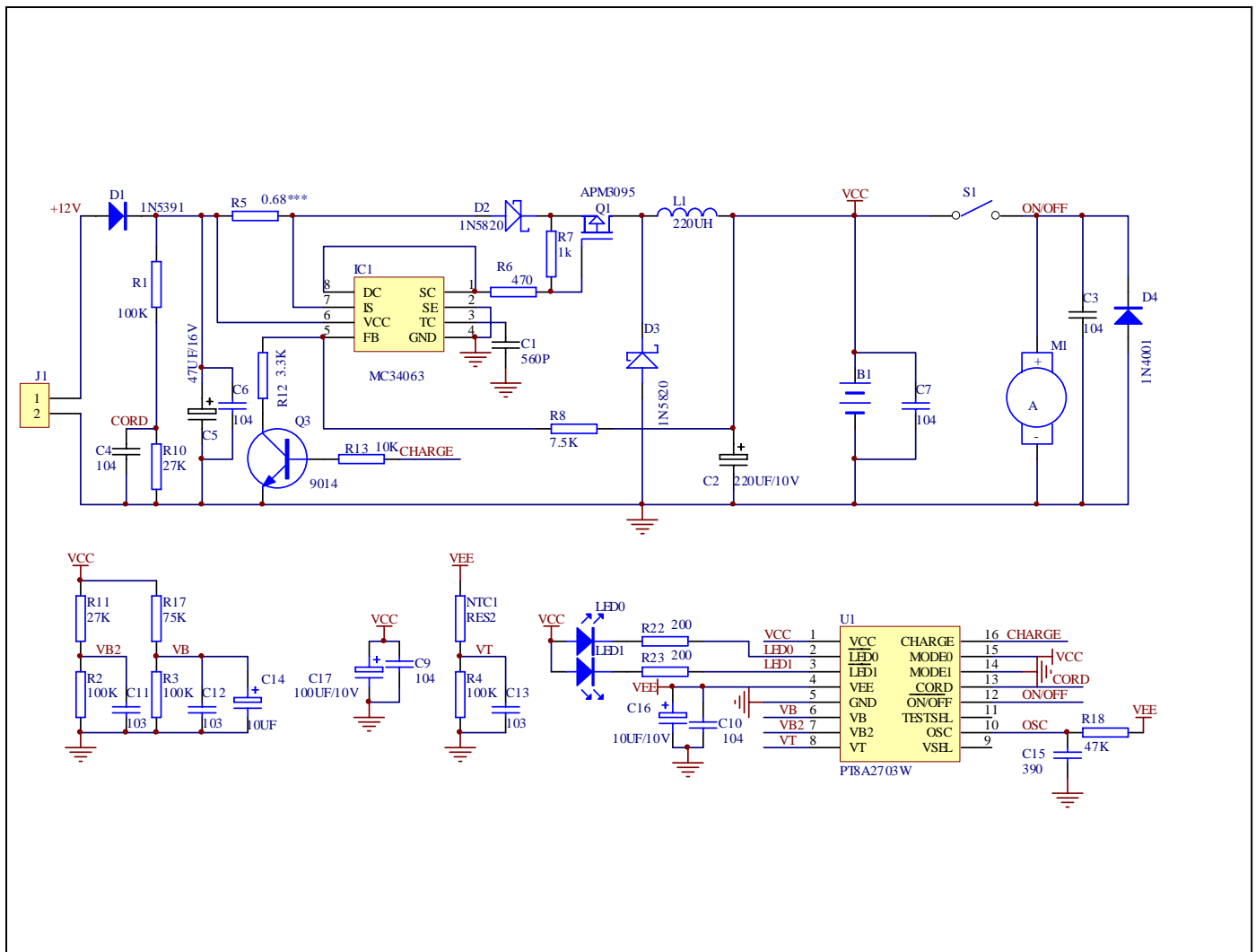

Slide Switch Mode(Zero Delta Voltage Detection) of 2713

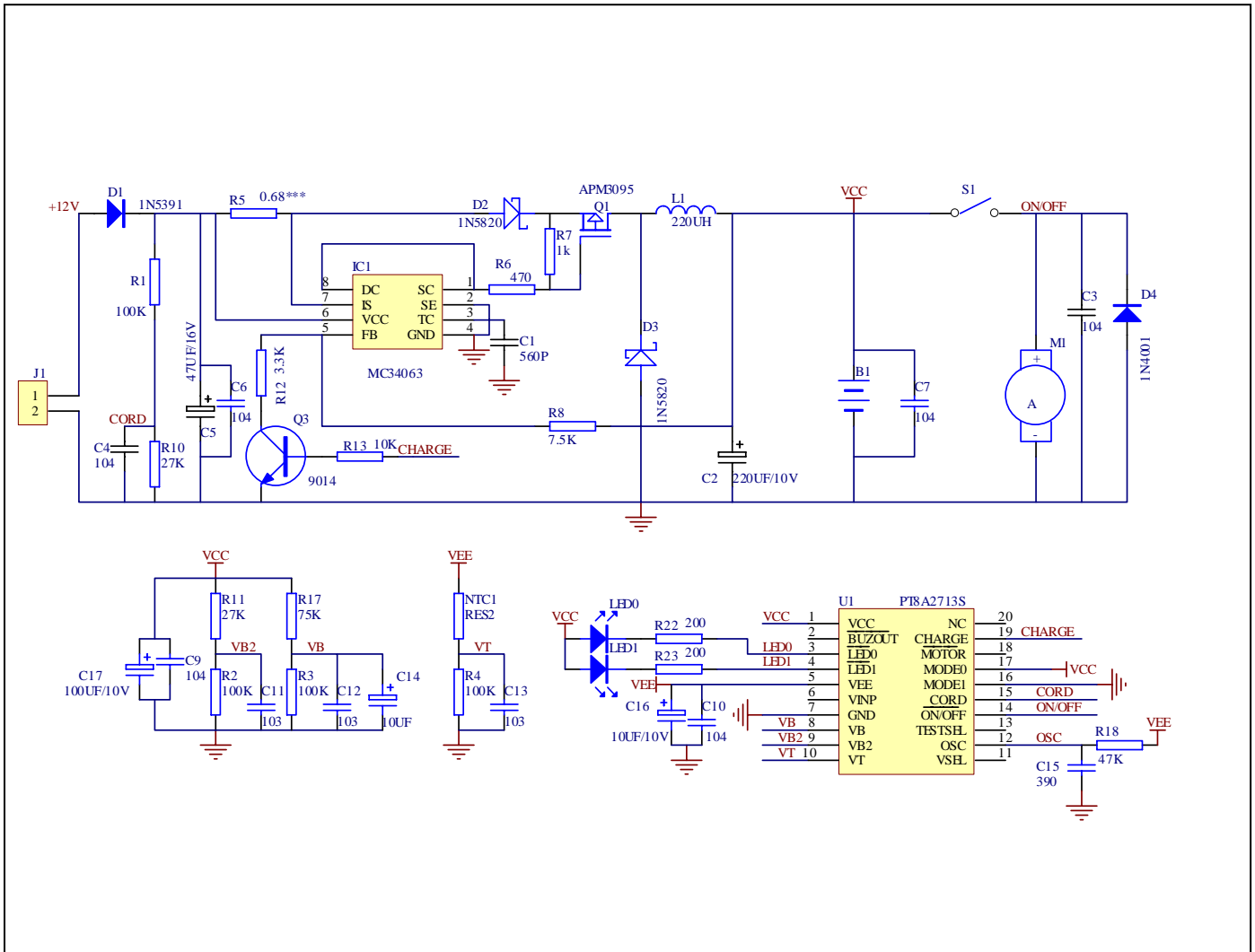

Tact Switch Mode(Zero Delta Voltage Detection) of 2713

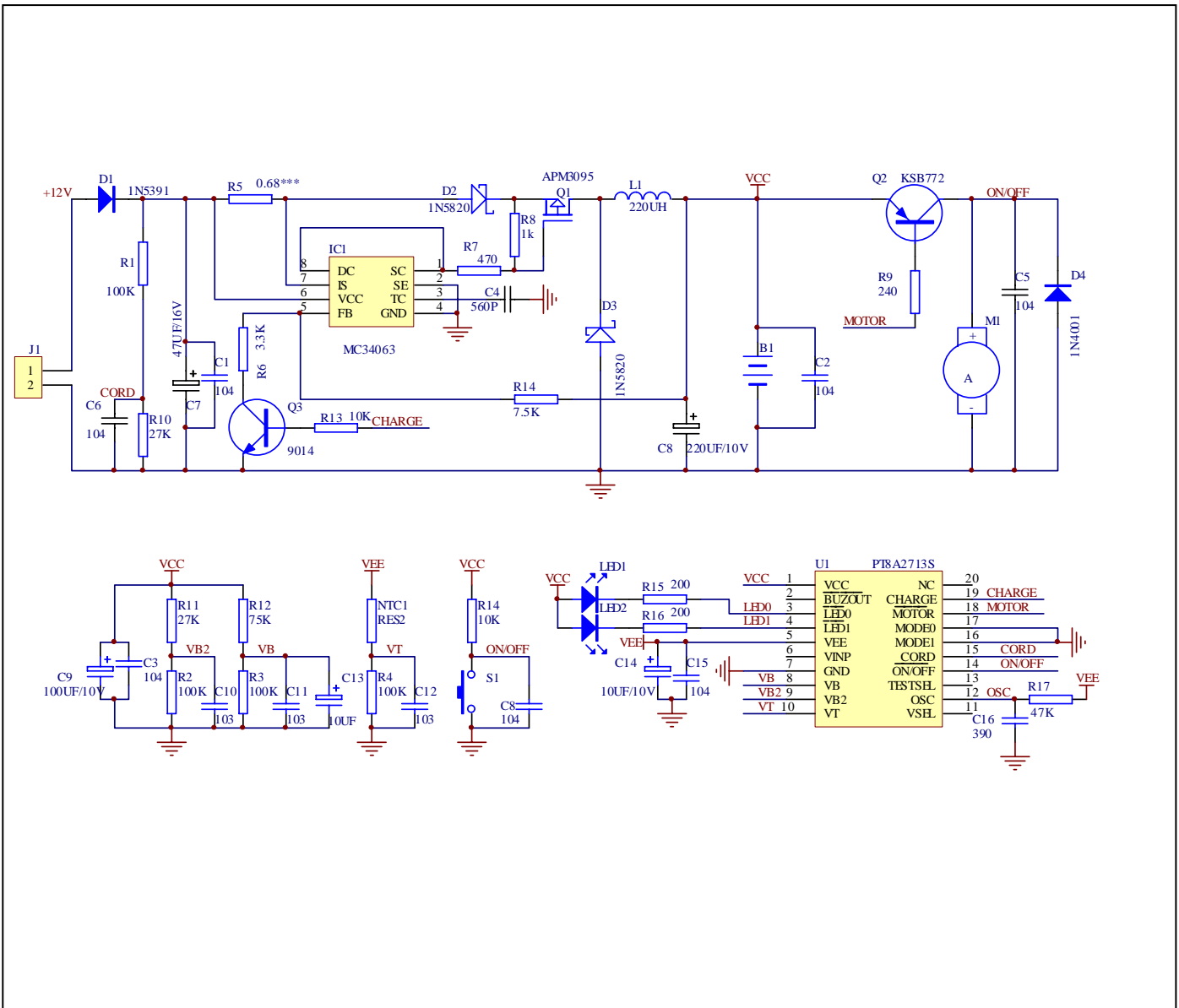

PCB Layout constraint.

1. Cross angle between two Tracks should be larger than 90 degree.
2. Track should be short and wide enough to reduce voltage drop, especially Power supply and Ground as well as some tracks flowing with large current, such as MC34063, switch Q1.
3. Some components need be far from MC34063, such as RC related to oscillator, electrolytic capacitance, NTC, because MC34063 may be very hot during charging mode.
4. A ceramic cap C6 about 104 need to add between VCC and Ground of MC34063 in order to prevent Charge control circuit from switch noise.
5. A ceramic cap C7 about 104 need to add between two poles of Battery.

Mechanical Information

16-Pin SOIC

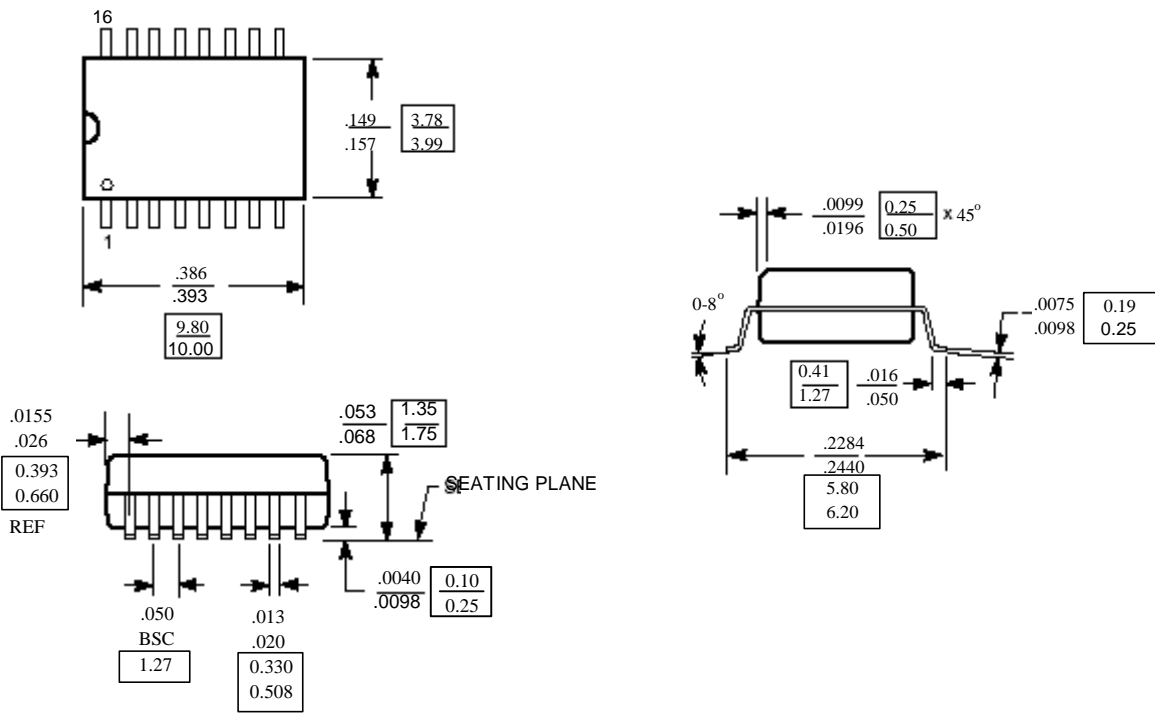

X.XX
X.XX DENOTES DIMENSIONS
IN MILLIMETERS

Notes:

- 1) Controlling dimensions in millimeters.
- 2) Ref: JDEDEC MS-012 AC

20-Pin SOIC

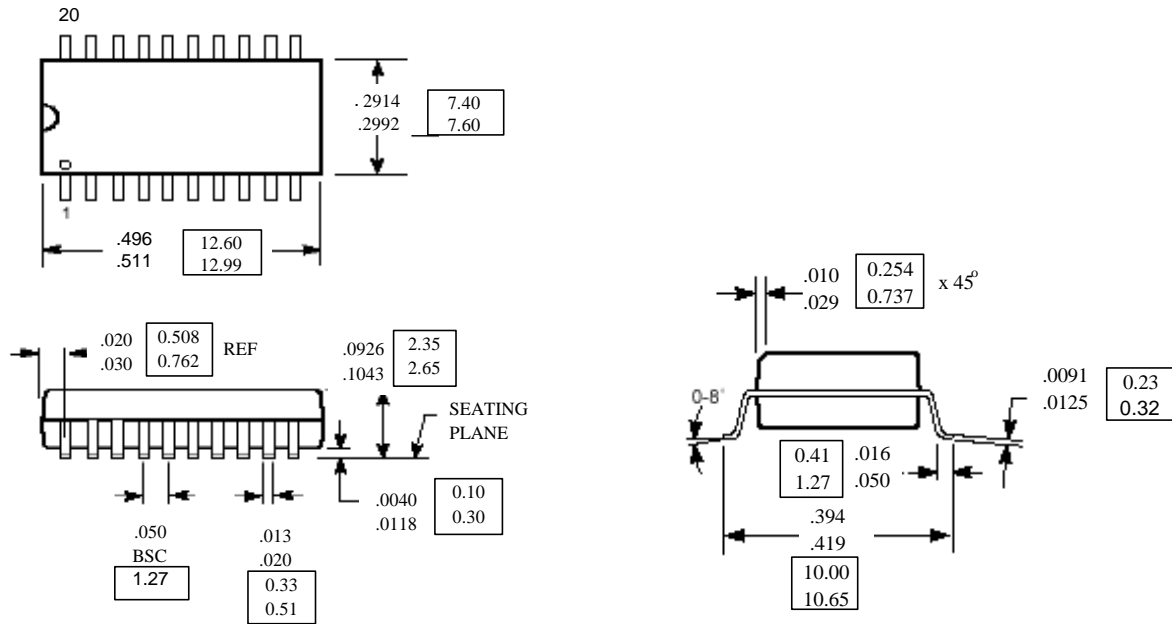

X.XX DENOTES DIMENSIONS
 X.XX IN MILLIMETERS

- Note:**
- 1) Controlling dimensions in millimeters.
 - 2) Ref: JDEDEC MS-013 AC

Notes

Pericom Technology Inc.

Email: support@pti.com.cn Web Site: www.pti.com.cn, www.pti-ic.com

China: No. 20 Building, 3/F, 481 Guiping Road, Shanghai, 200233, China
Tel: (86)-21-6485 0576 Fax: (86)-21-6485 2181

Asia Pacific: Unit 1517, 15/F, Chevalier Commercial Centre, 8 Wang Hoi Rd, Kowloon Bay, Hongkong
Tel: (852)-2243 3660 Fax: (852)- 2243 3667

U.S.A.: 3545 North First Street, San Jose, California 95134, USA
Tel: (1)-408-435 0800 Fax: (1)-408-435 1100

Pericom Technology Incorporation reserves the right to make changes to its products or specifications at any time, without notice, in order to improve design or performance and to supply the best possible product. Pericom Technology does not assume any responsibility for use of any circuitry described other than the circuitry embodied in Pericom Technology product. The company makes no representations that circuitry described herein is free from patent infringement or other rights, of Pericom Technology Incorporation.