



UF7476

Preliminary

POWER MOSFET

N-CHANNEL POWER MOSFET

DESCRIPTION

The UTC **UF7476** is an N-channel Power MOSFET, it uses UTC's advanced technology to provide the customers with high switching speed and minimum on-state resistance.

The UTC **UF7476** is suitable for various applications such as power management for Netcom, computing and portable applications, etc.

FEATURES

- * $R_{DS(ON)} < 8.0m\Omega @ V_{GS}=4.5V$
- * Ultra-low gate impedance
- * High switching speed

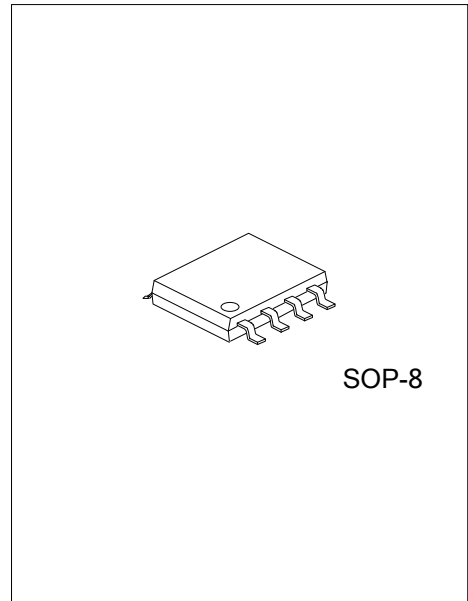

ORDERING INFORMATION

Ordering Number	Package	Pin Assignment								Packing
		1	2	3	4	5	6	7	8	
UF7476G-S08-R	SOP-8	S	S	S	G	D	D	D	D	Tape Reel

Note: Pin Assignment: G: Gate D: Drain S: Source

<p>UF7476G-S08-R</p> <p>(1)Packing Type</p> <p>(2)Package Type</p> <p>(3)Green Package</p>	<p>(1) R: Tape Reel</p> <p>(2) S08: SOP-8</p> <p>(3) G: Halogen Free and Lead Free</p>
--	--

■ MARKING

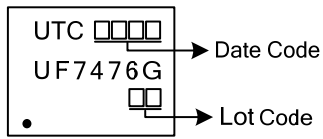

■ PIN CONFIGURATION

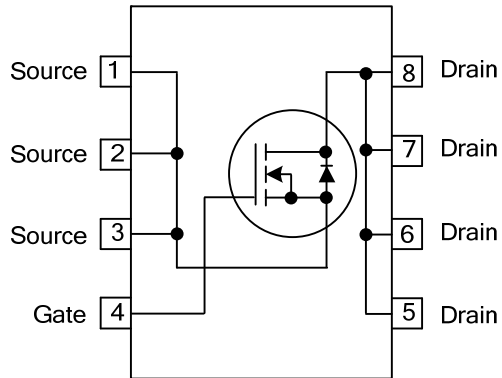

■ ABSOLUTE MAXIMUM RATING

PARAMETER		SYMBOL	RATINGS	UNIT
Drain-Source Voltage		V_{DSS}	12	V
Gate-Source Voltage		V_{GSS}	± 12	V
Drain Current	Continuous	$T_A=25^\circ\text{C}$	15	A
		$T_A=70^\circ\text{C}$	12	A
	Pulsed (Note 1)		I_{DM}	120
Avalanche Current (Note 1)		I_{AR}	12	A
Avalanche Energy (Note 3)		E_{AS}	60	mJ
Power Dissipation (Note 4)	$T_A=25^\circ\text{C}$	P_D	2.5	W
Linear Derating Factor			0.02	W/ $^\circ\text{C}$
Junction Temperature		T_J	+150	$^\circ\text{C}$
Storage Temperature Range		T_{STG}	-55~+150	$^\circ\text{C}$

Notes: 1. Absolute maximum ratings are those values beyond which the device could be permanently damaged.

Absolute maximum ratings are stress ratings only and functional device operation is not implied.

2. Repetitive Rating: Pulse width limited by maximum junction temperature
3. Starting $T_J = 25^\circ\text{C}$, $L=0.8\text{mH}$, $I_{AS}=12\text{A}$, $R_G = 25\Omega$
4. When mounted on 1 inch square copper board

■ THERMAL RESISTANCE

PARAMETER	SYMBOL	RATINGS	UNIT
Junction to Ambient (Note 4)	θ_{JA}	75	$^\circ\text{C/W}$

■ ELECTRICAL CHARACTERISTICS ($T_J = 25^\circ\text{C}$, unless otherwise specified)

PARAMETER	SYMBOL	TEST CONDITIONS	MIN	TYP	MAX	UNIT	
OFF CHARACTERISTICS							
Drain-Source Breakdown Voltage	BV_{DSS}	$I_D=250\mu\text{A}$, $V_{GS}=0\text{V}$	12			V	
Breakdown Voltage Temperature Coefficient	$\Delta BV_{DSS}/\Delta T_J$	Reference to 25°C , $I_D=1\text{mA}$		0.014		V/ $^\circ\text{C}$	
Drain-Source Leakage Current	I_{DSS}	$V_{DS}=9.6\text{V}$, $V_{GS}=0\text{V}$			100	μA	
		$V_{DS}=9.6\text{V}$, $V_{GS}=0\text{V}$, $T_J=125^\circ\text{C}$			250	μA	
Gate-Source Leakage Current	Forward	I_{GSS}			200	nA	
	Reverse						$V_{GS}=12\text{V}$, $V_{DS}=0\text{V}$
					-200	nA	
ON CHARACTERISTICS							
Static Drain-Source On-State Resistance (Note)	$R_{DS(ON)}$	$V_{GS}=4.5\text{V}$, $I_D=15\text{A}$		6.0	8.0	m Ω	
		$V_{GS}=2.8\text{V}$, $I_D=12\text{A}$		12	30	m Ω	
Gate Threshold Voltage	$V_{GS(TH)}$	$V_{DS}=V_{GS}$, $I_D=250\mu\text{A}$	0.6		1.9	V	
DYNAMIC PARAMETERS							
Input Capacitance	C_{ISS}	$V_{GS}=0\text{V}$, $V_{DS}=6.0\text{V}$, $f=1.0\text{MHz}$		2550		pF	
Output Capacitance	C_{OSS}			2190		pF	
Reverse Transfer Capacitance	C_{RSS}			450		pF	
SWITCHING PARAMETERS							
Total Gate Charge	Q_G	$I_D=12\text{A}$, $V_{DS}=10\text{V}$, $V_{GS}=4.5\text{V}$		26	40	nC	
Gate to Source Charge	Q_{GS}			4.6		nC	
Gate to Drain ("Miller") Charge	Q_{GD}			11		nC	
Output Gate Charge	Q_{OSS}	$V_{DS}=5.0\text{V}$, $V_{GS}=0\text{V}$		17		nC	
Turn-ON Delay Time	$t_{D(ON)}$	$V_{DD}=6.0\text{V}$, $I_D=12\text{A}$, $R_G=1.8\Omega$		11		ns	
Rise Time	t_R			29		ns	
Turn-OFF Delay Time	$t_{D(OFF)}$		$V_{GS}=4.5\text{V}$ (Note)		19		ns
Fall Time	t_F				8.3		ns

■ ELECTRICAL CHARACTERISTICS ($T_J = 25^\circ\text{C}$, unless otherwise specified)

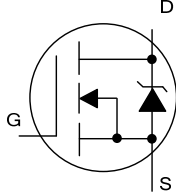
PARAMETER	SYMBOL	TEST CONDITIONS	MIN	TYP	MAX	UNIT
SOURCE- DRAIN DIODE RATINGS AND CHARACTERISTICS						
Maximum Body Diode Continuous Source Current	I_S	MOSFET symbol showing the integral reverse p-n junction diode.			2.5	A
Maximum Body Diode Pulsed Current (Note 1)	I_{SM}				120	A
Drain-Source Diode Forward Voltage (Note)	V_{SD}	$T_J=25^\circ\text{C}$, $I_S=12\text{A}$, $V_{GS}=0\text{V}$		0.87	1.2	V
		$T_J=125^\circ\text{C}$, $I_S=12\text{A}$, $V_{GS}=0\text{V}$		0.73		V
Body Diode Reverse Recovery Time	t_{RR}	$T_J=25^\circ\text{C}$, $I_F=12\text{A}$, $V_R=12\text{V}$, $di/dt=100\text{A}/\mu\text{s}$ (Note)		55	82	ns
Body Diode Reverse Recovery Charge	Q_{RR}	$T_J=25^\circ\text{C}$, $I_F=12\text{A}$, $V_R=12\text{V}$, $di/dt=100\text{A}/\mu\text{s}$ (Note)		59	89	nC
Body Diode Reverse Recovery Time	t_{RR}	$T_J=125^\circ\text{C}$, $I_F=12\text{A}$, $V_R=12\text{V}$, $di/dt=100\text{A}/\mu\text{s}$ (Note)		54	81	ns
Body Diode Reverse Recovery Charge	Q_{RR}	$T_J=125^\circ\text{C}$, $I_F=12\text{A}$, $V_R=12\text{V}$, $di/dt=100\text{A}/\mu\text{s}$ (Note)		60	90	nC

Notes: Pulse width $\leq 300\mu\text{s}$, Duty cycle $\leq 2\%$

■ TEST CIRCUITS AND WAVEFORMS

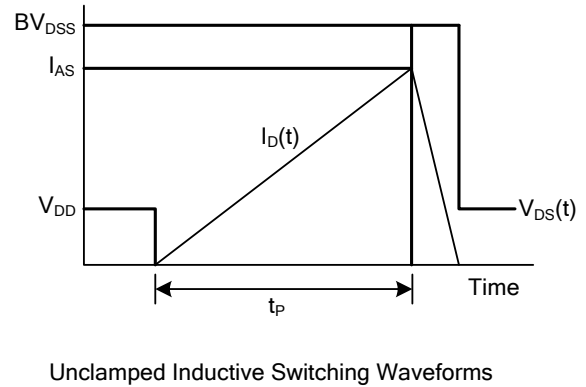
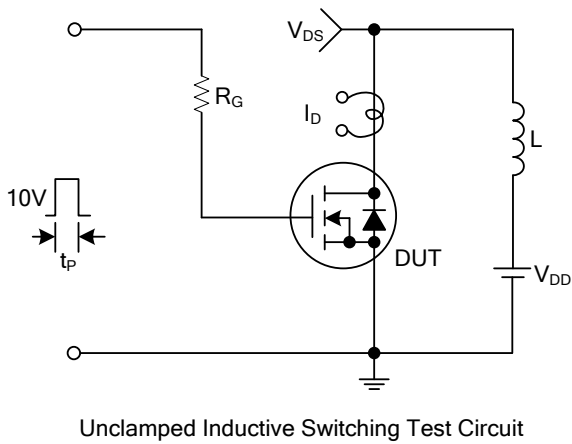
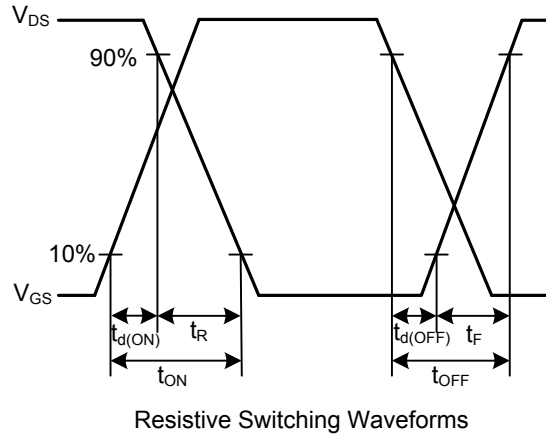
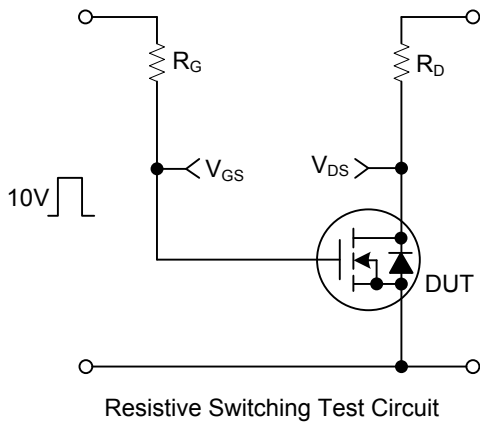
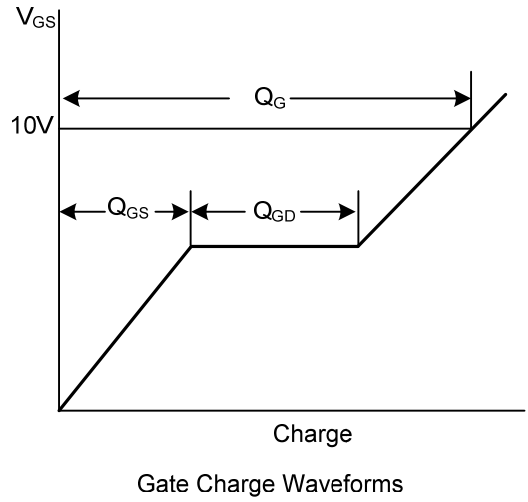
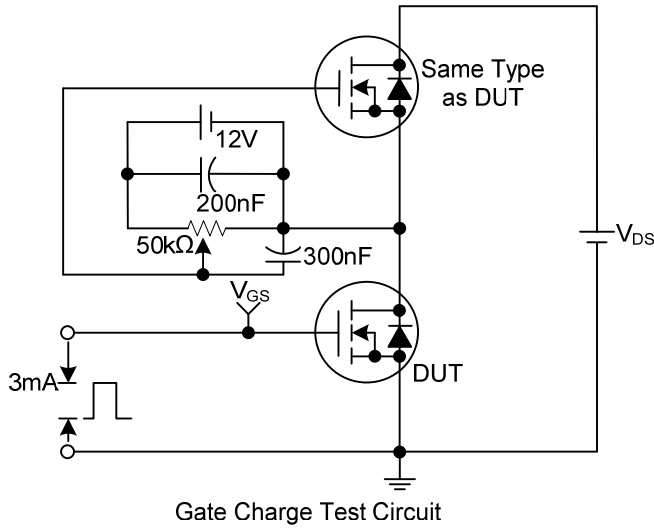

UTC assumes no responsibility for equipment failures that result from using products at values that exceed, even momentarily, rated values (such as maximum ratings, operating condition ranges, or other parameters) listed in products specifications of any and all UTC products described or contained herein. UTC products are not designed for use in life support appliances, devices or systems where malfunction of these products can be reasonably expected to result in personal injury. Reproduction in whole or in part is prohibited without the prior written consent of the copyright owner. The information presented in this document does not form part of any quotation or contract, is believed to be accurate and reliable and may be changed without notice.