

Wall Industries, Inc.

CV SERIES

1.8 to 45 Watts
2.5-5.5VDC, 4.5-14VDC, 10-30VDC Input Ranges
Adjustable Output Voltage
Negative and Positive Output Applications
Non-Isolated DC/DC Converters

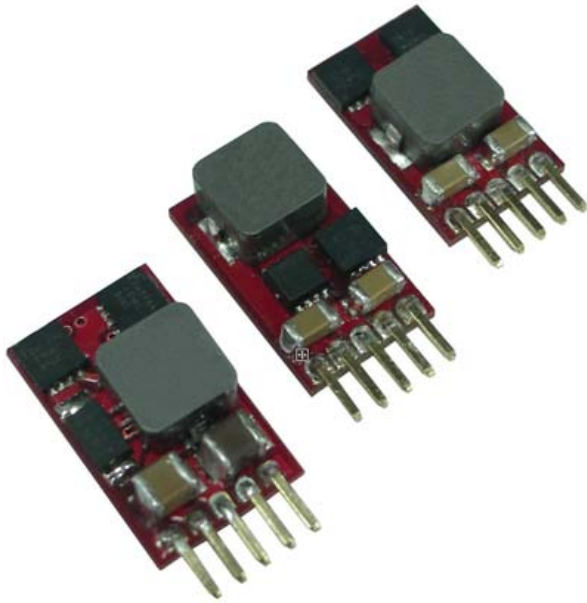

FEATURES

- Output Current up to 3A
- 1.8 to 45 Watts Output Power Range
- Adjustable Output Voltage
- High Efficiency - 95% at 12VDC and Full Load
- SIP Open Frame Packages
- Small Size and Profile
- Fixed Switching Frequency
- Remote On/Off
- Short Circuit, Over Current, and Over Temperature Protection
- Positive & Negative Output Applications
- Compliant to RoHS EU Directive 2011/65/EU
- UL60950-1, EN60950-1, and IEC60950-1 Safety Approvals
- Vertical Mounting and Horizontal Mounting Types Available

APPLICATIONS

- Wireless Networks
- Telecom / Datacom
- Industry Control Systems
- Semiconductor Equipment
- Distributed Power Architectures

DESCRIPTION

The CV series consists of non-isolated DC/DC converters that can deliver up to 3A of output current in a small open frame package. This series features remote on/off, adjustable output voltage, and efficiency up to 95%. These converters are protected against over current, over temperature, and short circuit conditions. The CV series is RoHS compliant and has UL60950-1, EN60950-1, and IEC60950-1 safety approvals. This series also has positive and negative output applications as well as vertical (standard) and horizontal ("A" suffix) SIP mounting options.

SPECIFICATIONS: CV SERIES						
All specifications are based on 25°C, Nominal Input Voltage, and Maximum Output Current unless otherwise noted. We reserve the right to change specifications based on technological advances.						
SPECIFICATION	TEST CONDITIONS		Min	Typ	Max	Unit
INPUT SPECIFICATIONS						
Operating Input Voltage Range ⁽³⁾	Positive Output Application					
	CV5S2.5-3000 (Vin>Vo+0.5V)	0.5Vin(nom), 0.6 ~ 3.3Vout	2.5		5.5	VDC
	CV12S3.3-3000 (Vin>Vo+2.0V)	12Vin(nom), 0.59 ~ 6.0Vout	4.5		14	
	CV24S5-3000 (Vin>Vo+3.0V)	24Vin(nom), 3.0 ~ 6.0Vout	10		30	
	CV24S12-3000 (Vin>Vo+3.0V)	24Vin(nom), 5.0 ~ 15Vout	10		30	
	Negative Output Application					
CV12S3.3-3000 (Vin _{max} =14- Vo)	12Vin(nom), -0.59 ~ -6.0Vout	4.7		13	VDC	
CV24S5-3000 (Vin _{max} =30- Vo)	12Vin(nom), -3.0 ~ -6.0Vout	10		27		
CV24S12-3000 (Vin _{max} =30- Vo)	12Vin(nom), -5.0 ~ -15Vout	10		25		
No Load Input Current			See Table			
Maximum Input Current	CV5S2.5-3000	Vin=Vin(min); Io=Io(max)			3.0	A
	CV12S3.3-3000				2.6	
	CV24S5-3000				2.2	
	CV24S12-3000				3.0	
Input Reflected Ripple Current	An external π filter is recommended at the input of the module in order to minimize input reflected ripple			30		mAp-p
Input Filter			C type			
Remote On/Off (Positive Logic)	CV5S2.5-3000	The On/Off control pin voltage is referenced to ground	ON = Open or Vin (max)			
	Others		OFF = 0V < Vr < 0.3V			
OUTPUT SPECIFICATIONS						
Voltage Adjustability ⁽¹⁾	See Figure 2		See Table			
Voltage Accuracy			-2.0		+2.0	%
Line Regulation	Vo ≥ 2.5VDC			0.2		%
	Vo < 2.5VDC			5		mV
Load Regulation	Vo ≥ 2.5VDC	0% to 100% of full load		0.8		%
	Vo < 2.5VDC			20		mV
	Vo ≥ 2.5VDC	10% to 90% of full load		0.6		%
	Vo < 2.5VDC			15		mV
Output Power			1.8 ~ 45 Watts			
Output Current			See Table			
Ripple & Noise (20MHz BW)	Positive Output Application					
	CV5S2.5-3000			30	55	mVp-p
	CV12S3.3-3000			60	85	
	CV24S5-3000	With 2.2μF MLCC		75	100	
	CV24S12-3000	With 2.2μF MLCC		150	200	
	Negative Output Application (See figure 1)					
CV12S3.3-3000			60	85	mVp-p	
CV24S5-3000	With C1=10μF/50V 1206 X5R MLCC		75	100		
CV24S12-3000	With C2=10μF/25V 1206 X5R MLCC		150	200		
Output Voltage Overshoot -Startup					1	%
Maximum Capacitive Load			See Table			
Rise Time	CV5S2.5-3000	Time for Vo to rise from 10% to 90% Vo			6	ms
	CV12S3.3-3000				6	
	CV24S5-3000				10	
	CV24S12-3000				10	
Dynamic Load Response	Peak Deviation	CV24S12-3000	50% load step change		150	mV
	Recovery Time	Others			250	
		All models		120		μs
Temperature Coefficient (max)			-1		+1	%/°C
PROTECTION						
Short Circuit Protection			continuous, automatic recovery			
Over Load Protection	CV5S2.5-3000	% of rated Iout; hiccup mode		280		%
	Others			220		
Over Temperature Protection	Internal IC Junction			150		°C

SPECIFICATIONS: CV SERIES					
All specifications are based on 25°C, Nominal Input Voltage, and Maximum Output Current unless otherwise noted. We reserve the right to change specifications based on technological advances.					
SPECIFICATION	TEST CONDITIONS	Min	Typ	Max	Unit
GENERAL SPECIFICATIONS					
Efficiency	Nominal input voltage and full load	See Table			
Switching Frequency	CV5S2.5-3000 & CV12S3.3-3000	540	600	660	KHz
	CV24S5-3000 & CV24S12-3000	270	300	330	
Isolation Voltage		none			
ENVIRONMENTAL SPECIFICATIONS					
Operating Temperature	See derating curves	-40		+85	°C
Storage Temperature		-55		+125	°C
Thermal Shock		MIL-STD-810F			
MTBF	BELLCORE TR-NWT-000332 Case 1: 50% Stress, Ta=40°C	6,250,000 hours			
	MIL-HDBK-217F Ta=25°C, full load, (G/B, controlled environment)	1,638,000 hours			
PHYSICAL SPECIFICATIONS					
Case Material		Open frame			
Potting Material		none			
Weight	CV5S2.5-3000 & CV12S3.3-3000	0.06oz (1.7g)			
	CV24S5-3000 & CV24S12-3000	0.074oz (2.1g)			
Dimensions (L x W x H)	CV5S2.5-3000 & CV12S3.3-3000	0.37 x 0.24 x 0.61 inches (9.4 x 6.0 x 15.5 mm)			
	CV24S5-3000 & CV24S12-3000	0.41 x 0.24 x 0.65 inches (10.4 x 6.0 x 16.5 mm)			
SAFETY					
Safety Approvals		IEC60950-1, UL60950-1, EN60950-1			

MODEL SELECTION TABLE									
POSITIVE OUTPUT APPLICATION									
Model Number	Input Range	Output Voltage ⁽¹⁾	Output Current	Maximum Input Current	No Load Input Current	Output Power	Efficiency	Max Capacitive Load	
								ESR≥1mΩ	ESR≥10mΩ
CV5S2.5-3000	2.5 ~ 5.5VDC	0.6 ~ 3.3 VDC	3A	3.0A	20mA	1.8W ~ 9.9W	95% @ 2.5Vo	1000μF	3000μF
CV12S3.3-3000	4.5 ~ 14VDC	0.59 ~ 6 VDC	3A	2.6A	25mA	1.77W ~ 18W	93% @ 3.3Vo	1000μF	3000μF
CV24S5-3000	10 ~ 30VDC	3 ~ 6 VDC	3A	2.2A	25mA	9W ~ 18W	91% @ 5.0Vo	1000μF	3000μF
CV24S12-3000	10 ~ 30VDC	5 ~ 15 VDC	3A	3.0A	30mA	15W ~ 45W	95% @ 12Vo	500μF	1200μF

NEGATIVE OUTPUT APPLICATION								
Model Number	Input Range	Output Voltage	Output Current ⁽²⁾	Maximum Input Current	No Load Input Current	Output Power	Efficiency	Max Capacitive Load
CV12S3.3-3000	4.7 ~ 13VDC	-0.59 ~ -6 VDC	2.2A	2.6A	35mA	1.3W ~ 13.2W	90% @ 3.3Vo	780μF
CV24S5-3000	10 ~ 27VDC	-3 ~ -6 VDC	2.2A	2.2A	35mA	6.6W ~ 13.2W	90% @ 5.0Vo	2200μF
CV24S12-3000	10 ~ 25VDC	-5 ~ -15 VDC	1.2A	3.0A	60mA	6W ~ 18W	91% @ 12Vo	580μF

NOTES

- Output voltage programmable from 0.6V to 3.3V, 0.59V to 6.0V, 3.0V to 6.0V, and 5.0V to 15V by connecting a single resistor between the TRIM and GND pins of the module. To calculate the value of the resistor (R_{trim}) for a particular output voltage (V_o), use the equations shown in **Table 1**.
- CV12S3.3-3000: When using negative output application, $|V_o|$ trim up > 3.3V and the output current is 1.5A max.
- CV12S3.3-3000: When $V_{o,set} < 0.9VDC$ the input voltage range is 4.5 ~ 9 VDC.
- Both vertical mounting and horizontal mounting SIP types are available. Add the suffix "A" to the model number for horizontal mounting SIP type.
- CAUTION: This power module is not internally fused. An input line fuse must always be used.**

CHARACTERISTIC CURVES

POSITIVE OUTPUT APPLICATION

NEGATIVE OUTPUT APPLICATION

CV12S3.3-3000 Derating Curve

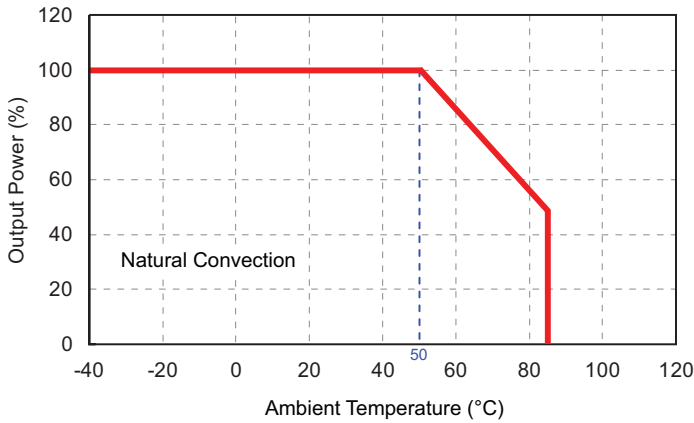

CV12S3.3-3000 Derating Curve

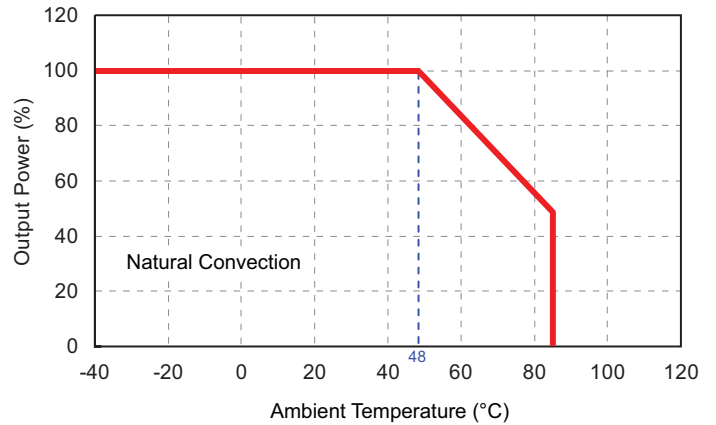

CV12S3.3-3000 Efficiency vs Input Voltage

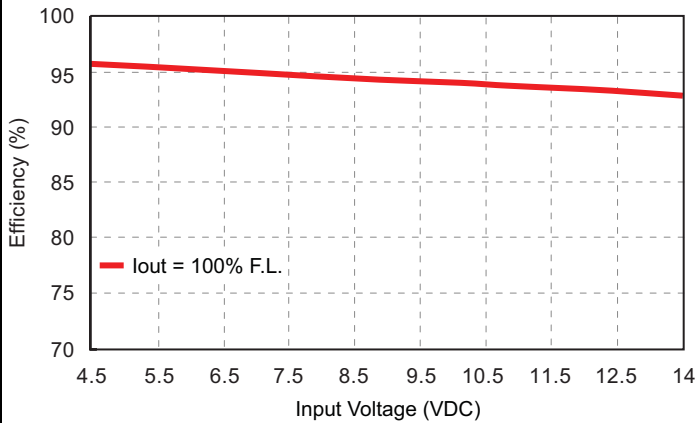

CV12S3.3-3000 Efficiency vs Input Voltage

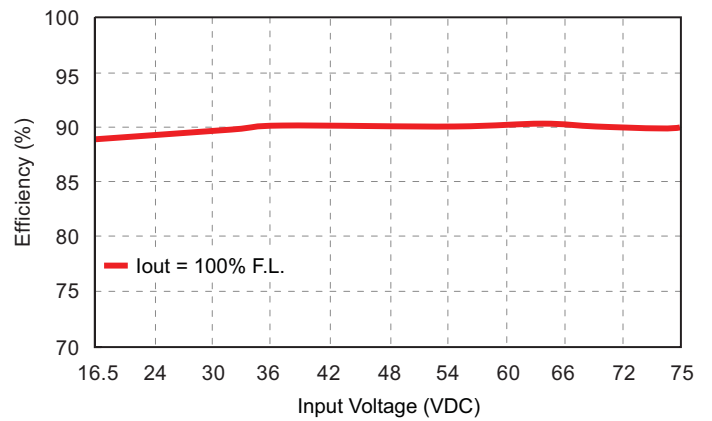

CV12S3.3-3000 Efficiency vs Output Load

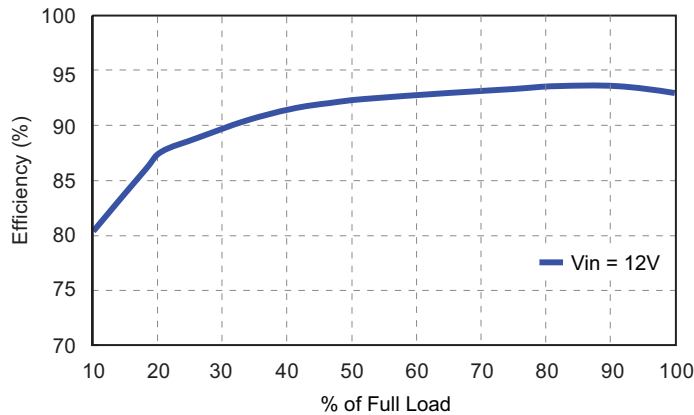

CV12S3.3-3000 Efficiency vs Output Load

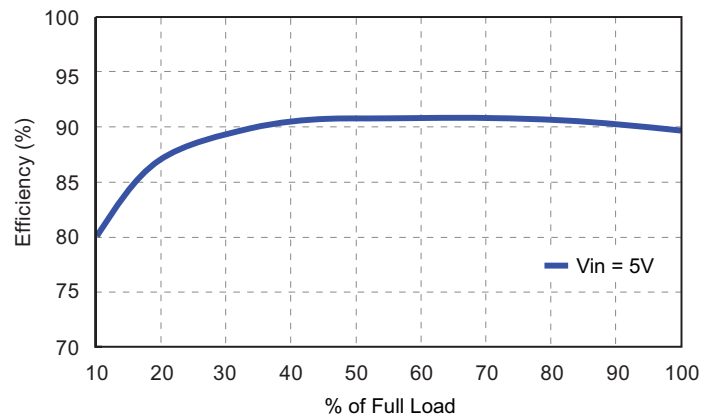

MECHANICAL DRAWINGS

VERTICAL MOUNTING SIP TYPE (Standard)	HORIZONTAL MOUNTING SIP TYPE ("A" Suffix)																																										
CV5S2.5-3000	CV5S2.5-3000A																																										
<p>Unit: inches (mm)</p> <table border="1" style="margin-left: auto; margin-right: auto;"> <thead> <tr> <th colspan="3">PIN CONNECTIONS</th> </tr> <tr> <th>Pin</th> <th>Positive Output</th> <th>Negative Output</th> </tr> </thead> <tbody> <tr> <td>1</td> <td>Ctrl</td> <td>Ctrl</td> </tr> <tr> <td>2</td> <td>+Vin</td> <td>+Vin</td> </tr> <tr> <td>3</td> <td>GND</td> <td>-Vout</td> </tr> <tr> <td>4</td> <td>+Vout</td> <td>GND</td> </tr> <tr> <td>5</td> <td>Trim</td> <td>Trim</td> </tr> </tbody> </table> <p style="text-align: center;">Tolerance: X.XX±0.02 (X.X±0.5) X.XXX±0.01 (X.XX±0.25) Pin Pitch Tolerance: ±0.01 (±0.25) Pin Dimension Tolerance: ±0.004 (±0.1)</p>	PIN CONNECTIONS			Pin	Positive Output	Negative Output	1	Ctrl	Ctrl	2	+Vin	+Vin	3	GND	-Vout	4	+Vout	GND	5	Trim	Trim	<p>Unit: inches (mm)</p> <table border="1" style="margin-left: auto; margin-right: auto;"> <thead> <tr> <th colspan="3">PIN CONNECTIONS</th> </tr> <tr> <th>Pin</th> <th>Positive Output</th> <th>Negative Output</th> </tr> </thead> <tbody> <tr> <td>1</td> <td>Ctrl</td> <td>Ctrl</td> </tr> <tr> <td>2</td> <td>+Vin</td> <td>+Vin</td> </tr> <tr> <td>3</td> <td>GND</td> <td>-Vout</td> </tr> <tr> <td>4</td> <td>+Vout</td> <td>GND</td> </tr> <tr> <td>5</td> <td>Trim</td> <td>Trim</td> </tr> </tbody> </table> <p style="text-align: center;">Tolerance: X.XX±0.02 (X.X±0.5) X.XXX±0.01 (X.XX±0.25) Pin Pitch Tolerance: ±0.01 (±0.25) Pin Dimension Tolerance: ±0.004 (±0.1)</p>	PIN CONNECTIONS			Pin	Positive Output	Negative Output	1	Ctrl	Ctrl	2	+Vin	+Vin	3	GND	-Vout	4	+Vout	GND	5	Trim	Trim
PIN CONNECTIONS																																											
Pin	Positive Output	Negative Output																																									
1	Ctrl	Ctrl																																									
2	+Vin	+Vin																																									
3	GND	-Vout																																									
4	+Vout	GND																																									
5	Trim	Trim																																									
PIN CONNECTIONS																																											
Pin	Positive Output	Negative Output																																									
1	Ctrl	Ctrl																																									
2	+Vin	+Vin																																									
3	GND	-Vout																																									
4	+Vout	GND																																									
5	Trim	Trim																																									
CV12S3.3-3000	CV12S3.3-3000A																																										
<p>Unit: inches (mm)</p> <table border="1" style="margin-left: auto; margin-right: auto;"> <thead> <tr> <th colspan="3">PIN CONNECTIONS</th> </tr> <tr> <th>Pin</th> <th>Positive Output</th> <th>Negative Output</th> </tr> </thead> <tbody> <tr> <td>1</td> <td>Ctrl</td> <td>Ctrl</td> </tr> <tr> <td>2</td> <td>+Vin</td> <td>+Vin</td> </tr> <tr> <td>3</td> <td>GND</td> <td>-Vout</td> </tr> <tr> <td>4</td> <td>+Vout</td> <td>GND</td> </tr> <tr> <td>5</td> <td>Trim</td> <td>Trim</td> </tr> </tbody> </table> <p style="text-align: center;">Tolerance: X.XX±0.02 (X.X±0.5) X.XXX±0.01 (X.XX±0.25) Pin Pitch Tolerance: ±0.01 (±0.25) Pin Dimension Tolerance: ±0.004 (±0.1)</p>	PIN CONNECTIONS			Pin	Positive Output	Negative Output	1	Ctrl	Ctrl	2	+Vin	+Vin	3	GND	-Vout	4	+Vout	GND	5	Trim	Trim	<p>Unit: inches (mm)</p> <table border="1" style="margin-left: auto; margin-right: auto;"> <thead> <tr> <th colspan="3">PIN CONNECTIONS</th> </tr> <tr> <th>Pin</th> <th>Positive Output</th> <th>Negative Output</th> </tr> </thead> <tbody> <tr> <td>1</td> <td>Ctrl</td> <td>Ctrl</td> </tr> <tr> <td>2</td> <td>+Vin</td> <td>+Vin</td> </tr> <tr> <td>3</td> <td>GND</td> <td>-Vout</td> </tr> <tr> <td>4</td> <td>+Vout</td> <td>GND</td> </tr> <tr> <td>5</td> <td>Trim</td> <td>Trim</td> </tr> </tbody> </table> <p style="text-align: center;">Tolerance: X.XX±0.02 (X.X±0.5) X.XXX±0.01 (X.XX±0.25) Pin Pitch Tolerance: ±0.01 (±0.25) Pin Dimension Tolerance: ±0.004 (±0.1)</p>	PIN CONNECTIONS			Pin	Positive Output	Negative Output	1	Ctrl	Ctrl	2	+Vin	+Vin	3	GND	-Vout	4	+Vout	GND	5	Trim	Trim
PIN CONNECTIONS																																											
Pin	Positive Output	Negative Output																																									
1	Ctrl	Ctrl																																									
2	+Vin	+Vin																																									
3	GND	-Vout																																									
4	+Vout	GND																																									
5	Trim	Trim																																									
PIN CONNECTIONS																																											
Pin	Positive Output	Negative Output																																									
1	Ctrl	Ctrl																																									
2	+Vin	+Vin																																									
3	GND	-Vout																																									
4	+Vout	GND																																									
5	Trim	Trim																																									
CV24S5-3000 & CV24S12-3000	CV24S5-3000A & CV24S12-3000A																																										
<p>Unit: inches (mm)</p> <table border="1" style="margin-left: auto; margin-right: auto;"> <thead> <tr> <th colspan="3">PIN CONNECTIONS</th> </tr> <tr> <th>Pin</th> <th>Positive Output</th> <th>Negative Output</th> </tr> </thead> <tbody> <tr> <td>1</td> <td>Ctrl</td> <td>Ctrl</td> </tr> <tr> <td>2</td> <td>+Vin</td> <td>+Vin</td> </tr> <tr> <td>3</td> <td>GND</td> <td>-Vout</td> </tr> <tr> <td>4</td> <td>+Vout</td> <td>GND</td> </tr> <tr> <td>5</td> <td>Trim</td> <td>Trim</td> </tr> </tbody> </table> <p style="text-align: center;">Tolerance: X.XX±0.02 (X.X±0.5) X.XXX±0.01 (X.XX±0.25) Pin Pitch Tolerance: ±0.01 (±0.25) Pin Dimension Tolerance: ±0.004 (±0.1)</p>	PIN CONNECTIONS			Pin	Positive Output	Negative Output	1	Ctrl	Ctrl	2	+Vin	+Vin	3	GND	-Vout	4	+Vout	GND	5	Trim	Trim	<p>Unit: inches (mm)</p> <table border="1" style="margin-left: auto; margin-right: auto;"> <thead> <tr> <th colspan="3">PIN CONNECTIONS</th> </tr> <tr> <th>Pin</th> <th>Positive Output</th> <th>Negative Output</th> </tr> </thead> <tbody> <tr> <td>1</td> <td>Ctrl</td> <td>Ctrl</td> </tr> <tr> <td>2</td> <td>+Vin</td> <td>+Vin</td> </tr> <tr> <td>3</td> <td>GND</td> <td>-Vout</td> </tr> <tr> <td>4</td> <td>+Vout</td> <td>GND</td> </tr> <tr> <td>5</td> <td>Trim</td> <td>Trim</td> </tr> </tbody> </table> <p style="text-align: center;">Tolerance: X.XX±0.02 (X.X±0.5) X.XXX±0.01 (X.XX±0.25) Pin Pitch Tolerance: ±0.01 (±0.25) Pin Dimension Tolerance: ±0.004 (±0.1)</p>	PIN CONNECTIONS			Pin	Positive Output	Negative Output	1	Ctrl	Ctrl	2	+Vin	+Vin	3	GND	-Vout	4	+Vout	GND	5	Trim	Trim
PIN CONNECTIONS																																											
Pin	Positive Output	Negative Output																																									
1	Ctrl	Ctrl																																									
2	+Vin	+Vin																																									
3	GND	-Vout																																									
4	+Vout	GND																																									
5	Trim	Trim																																									
PIN CONNECTIONS																																											
Pin	Positive Output	Negative Output																																									
1	Ctrl	Ctrl																																									
2	+Vin	+Vin																																									
3	GND	-Vout																																									
4	+Vout	GND																																									
5	Trim	Trim																																									

NEGATIVE OUTPUT APPLICATION

C1 and C2 are required and should be connected as close as possible to the converter pins

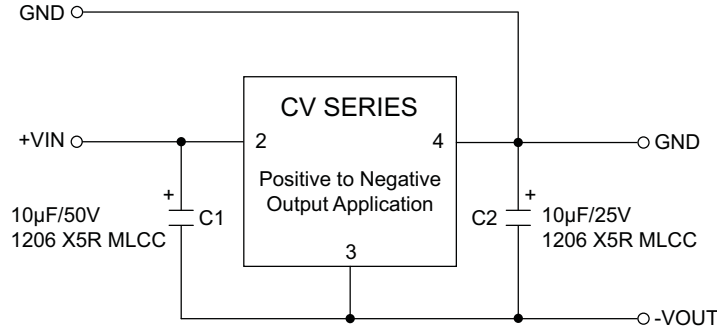

Figure 1

TRIM APPLICATION

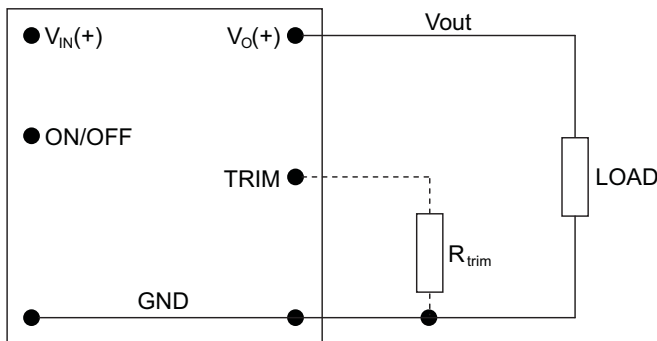

Figure 2

Model Name	R _{trim_up} (KΩ)
CV5S2.5-3000	$\frac{1.2}{V_o - 0.6} - 0.01$
CV12S3.3-3000	$\frac{1.18}{V_o - 0.59}$
CV24S5-3000	$\frac{11.2}{V_o - 3}$
CV24S12-3000	$\frac{8.4}{V_o - 5}$

Table 1

COMPANY INFORMATION

Wall Industries, Inc. has created custom and modified units for over 50 years. Our in-house research and development engineers will provide a solution that exceeds your performance requirements on-time and on budget. Our ISO9001-2008 certification is just one example of our commitment to producing a high quality, well-documented product for our customers.

Our past projects demonstrate our commitment to you, our customer. Wall Industries, Inc. has a reputation for working closely with its customers to ensure each solution meets or exceeds form, fit and function requirements. We will continue to provide ongoing support for your project above and beyond the design and production phases. Give us a call today to discuss your future projects.

Contact **Wall Industries** for further information:

Phone: ☎ (603)778-2300
 Toll Free: ☎ (888)587-9255
 Fax: ☎ (603)778-9797
 E-mail: sales@wallindustries.com
 Web: www.wallindustries.com
 Address: 5 Watson Brook Rd.
 Exeter, NH 03833