



SOT108-1

SO14; Reel sulfur barrier pack, SMD, 13"
Q1/T1 standard product orientation
Orderable part number ending ,431 or Z
Ordering code (12NC) ending 431

Rev. 1 — 19 August 2015

Packing information

1. Packing method

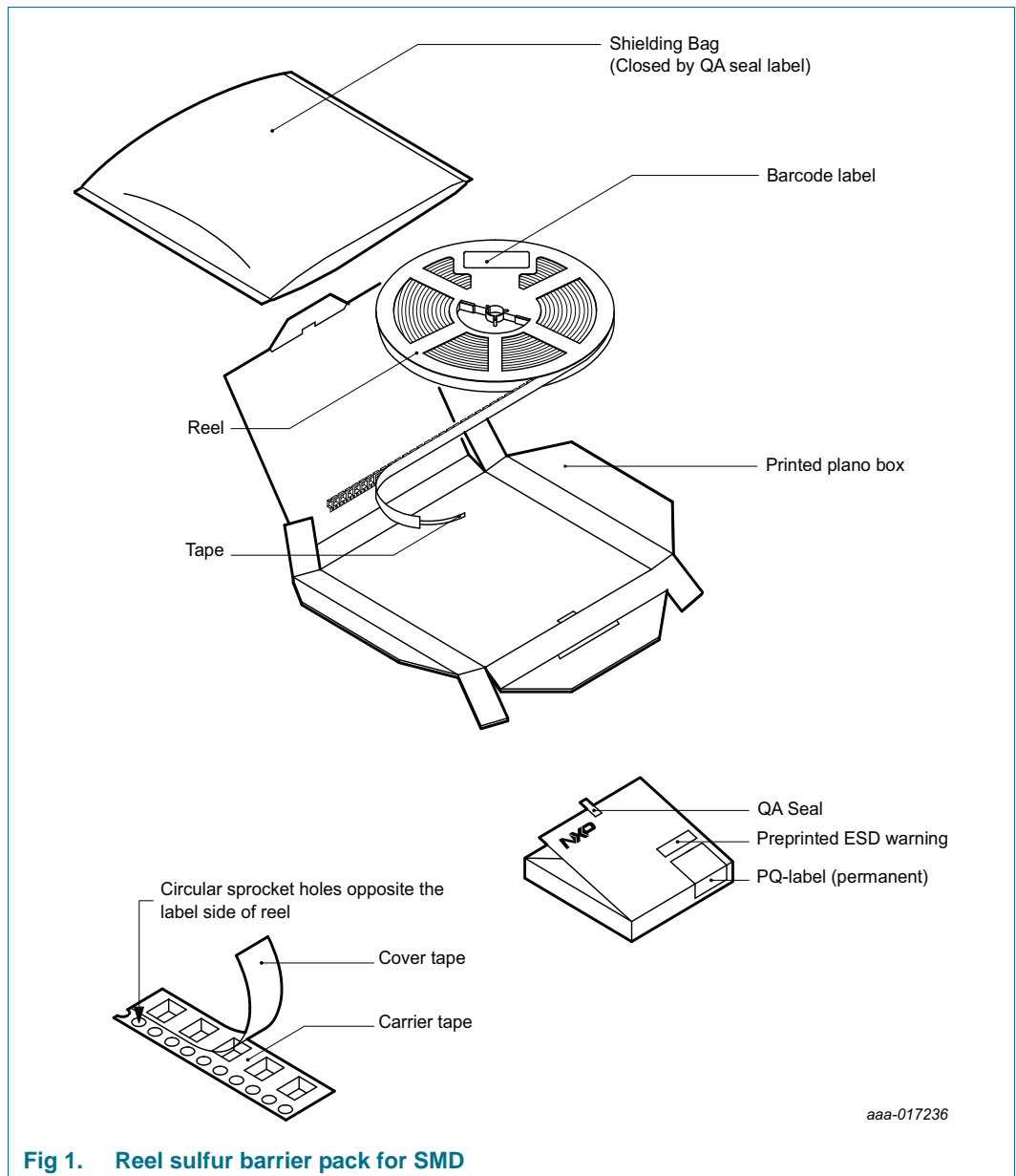

Fig 1. Reel sulfur barrier pack for SMD



SO14; Reel sulfur barrier pack, SMD, 13"
 Q1/T1 standard product orientation
 Orderable part number ending ,431 or Z
 Ordering code (12NC) ending 431

Table 1. Dimensions and quantities

Reel dimensions d × w (mm) [1]	SPQ/PQ (pcs) [2]	Reels per box	Outer box dimensions l × w × h (mm)
330 × 16	2500	1	342 × 338 × 31

[1] d = reel diameter; w = tape width.

[2] Packing quantity dependent on specific product type.

View ordering and availability details at [NXP order portal](#), or contact your local NXP representative.

2. Product orientation

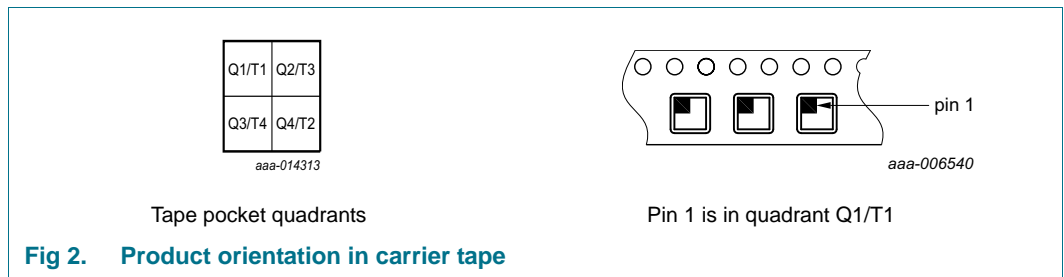

Fig 2. Product orientation in carrier tape

3. Carrier tape dimensions

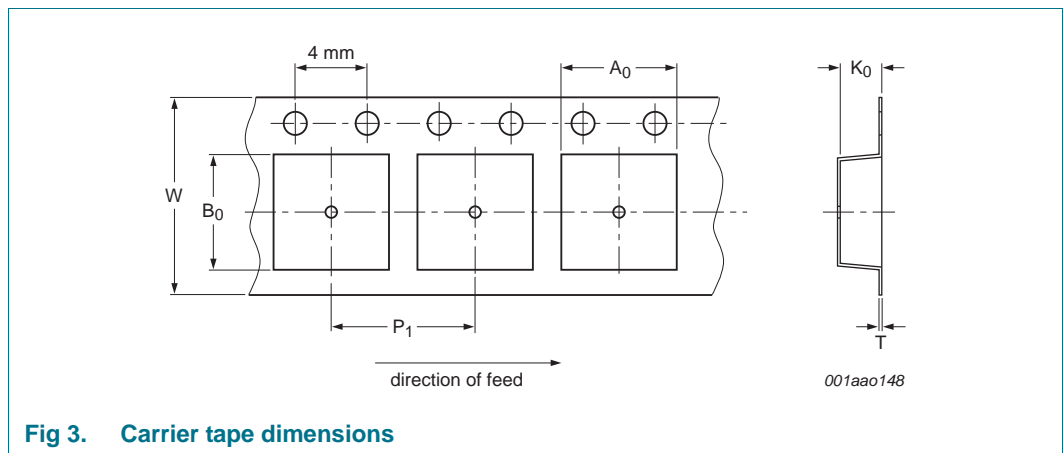

Fig 3. Carrier tape dimensions

Table 2. Carrier tape dimensions

In accordance with IEC 60286-3.

A ₀ (mm)	B ₀ (mm)	K ₀ (mm)	T (mm)	P ₁ (mm)	W (mm)
6.5 ± 0.1	9.5 ± 0.1	2.3 ± 0.1	0.3 ± 0.05	8.0 ± 0.1	16 ± 0.1

SO14; Reel sulfur barrier pack, SMD, 13"
 Q1/T1 standard product orientation
 Orderable part number ending ,431 or Z
 Ordering code (12NC) ending 431

4. Reel dimensions

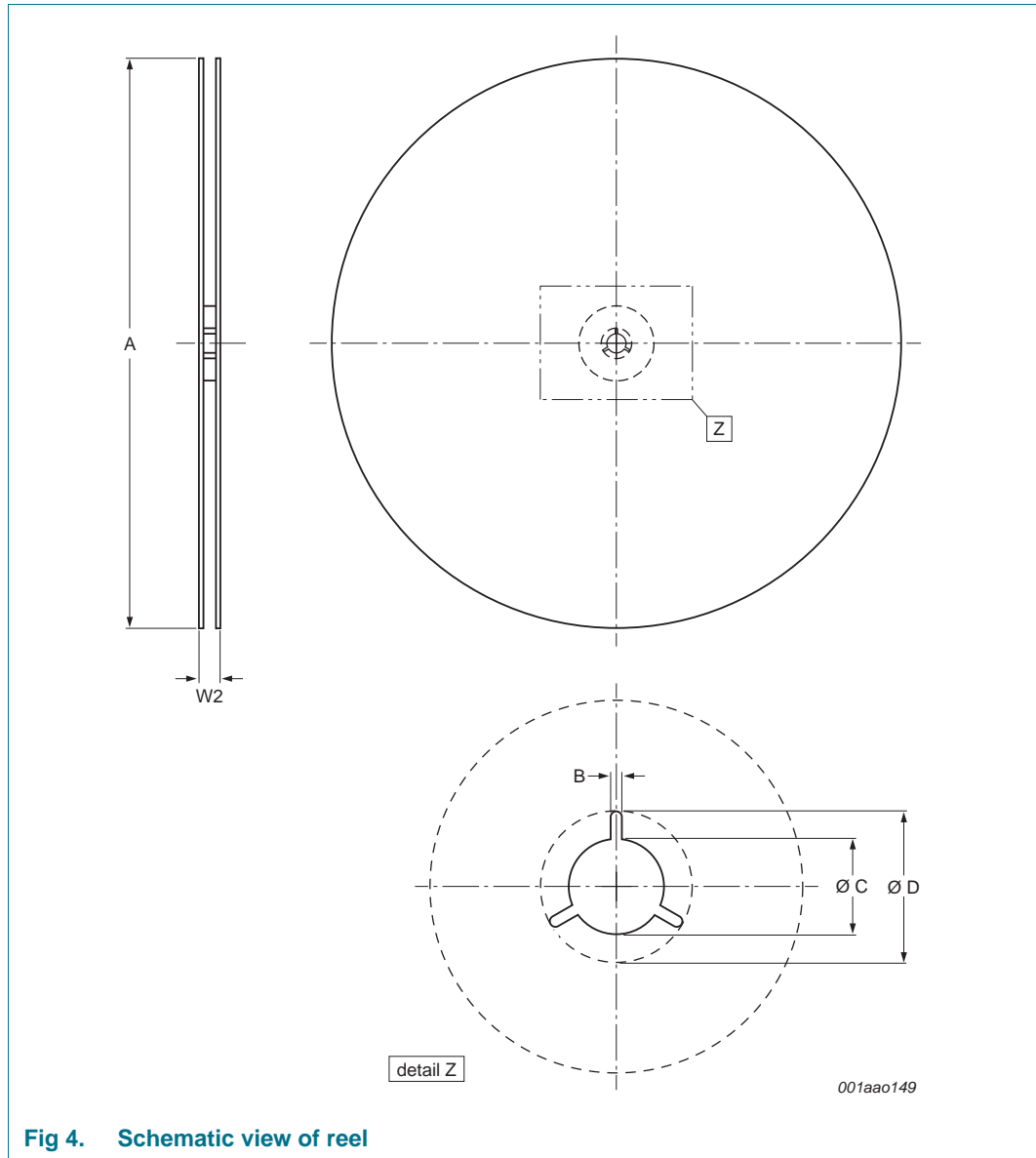

Fig 4. Schematic view of reel

Table 3. Reel dimensions
 In accordance with IEC 60286-3.

A [nom] (mm)	W2 [max] (mm)	B [min] (mm)	C [min] (mm)	D [min] (mm)
330	22.4	1.5	12.8	20.2

SO14; Reel sulfur barrier pack, SMD, 13"
 Q1/T1 standard product orientation
 Orderable part number ending ,431 or Z
 Ordering code (12NC) ending 431

5. Barcode label

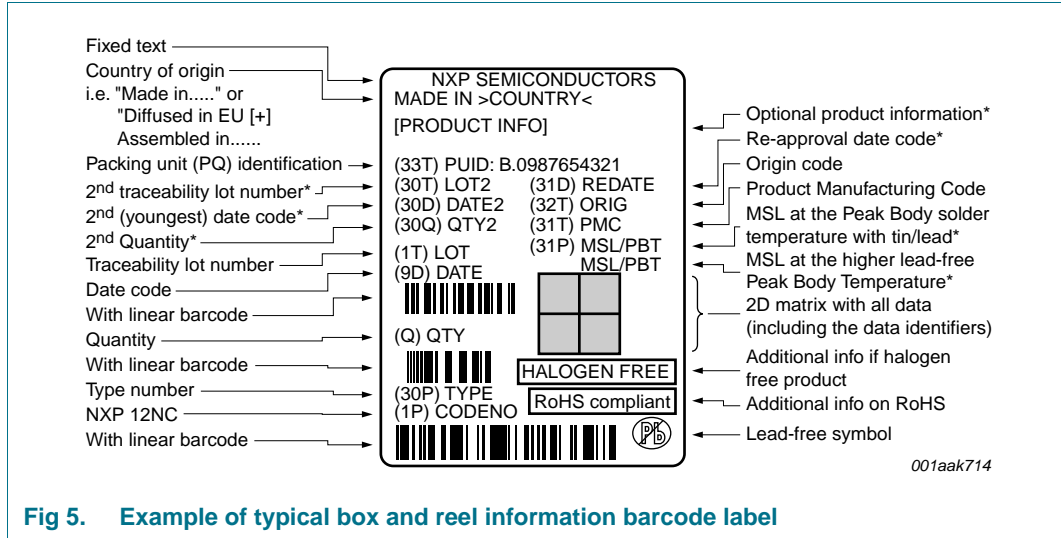

Fig 5. Example of typical box and reel information barcode label

Table 4. Barcode label dimensions

Box barcode label l × w (mm)	Reel barcode label l × w (mm)
100 × 75	100 × 75

SO14; Reel sulfur barrier pack, SMD, 13"
Q1/T1 standard product orientation
Orderable part number ending ,431 or Z
Ordering code (12NC) ending 431

6. Revision history

Table 5. Revision history

Document ID	Release date	Packing document status	Change notice	Supersedes
SOT108-1_431	20150819	Packing information	-	-

Limited warranty and liability

Information in this document is believed to be accurate and reliable. However, NXP Semiconductors does not give any representations or warranties, expressed or implied, as to the accuracy or completeness of such information and shall have no liability for the consequences of use of such information.

© NXP Semiconductors N.V. 2015.

All rights reserved.

For more information, please visit: <http://www.nxp.com>

For sales office addresses, please send an email to: salesaddresses@nxp.com

Date of release: 19 August 2015

Document identifier: SOT108-1_431