

## Features

- ▶ Supply voltage range 2.2 V to 3.6 V
- ▶ Low sleep current of 0.4  $\mu$ A
- ▶ Up to 1 MHz HALIOS<sup>®</sup> frequency
- ▶ 3 independent sending channels
- ▶ Each sending channel with up to 100mA LED current
- ▶ Ambient Light Measurement (ALS)
- ▶ High speed I<sup>2</sup>C interface (up to 3.4 MHz)
- ▶ New electro-optical basic coupling implemented
- ▶ Front-end solution to be used with any MCU
- ▶ Small size Bare-Die or QFN package

## Added Values

- ▶ HALIOS<sup>®</sup> – the No. 1 IR sensor in the automotive market
- ▶ Almost no external components needed
- ▶ Cyclic measurements for lowest power consumption
- ▶ Best ambient light immunity
- ▶ ALS independent from proximity detection
- ▶ Excellent temperature stability, sensitivity and speed
- ▶ Reference electrical schematics and layout are available
- ▶ Not affected by fluorescent lamps

## Ordering Information

Product ID	Temp.-Range	Package
E909.11	-40°C to +85°C	Bare-Die
E909.11	-40°C to +85°C	QFN20L4

## Applications

- ▶ High performance proximity detection up to 500 mm
- ▶ Fast and reliable 3D gesture control solution for mobile and industrial devices
- ▶ Gesture sensor IC for mobile devices (e.g. smart phones, tablets, PDAs, notebooks, laptops, digital cameras and more consumer products) for touch screen locking, power saving, etc.
- ▶ Ambient light interface function for dimming of mobile devices and display/keypad contrast control
- ▶ Gesture sensor IC for consumer, computing and industrial devices and displays

## General Description

Far reaching, stable proximity detection and an ALS input enables highly improved quality for well known features. Proven optical reliability – the original from the inventor!

Lowest current consumption together with the outstanding HALIOS<sup>®</sup> advantages makes this product suitable for every (mobile) device. The high HALIOS<sup>®</sup> frequency shortens the active measurement time to the minimum. Easy to use due to optimized pre-settings based on many years of application experience.

## Typical Application Circuit

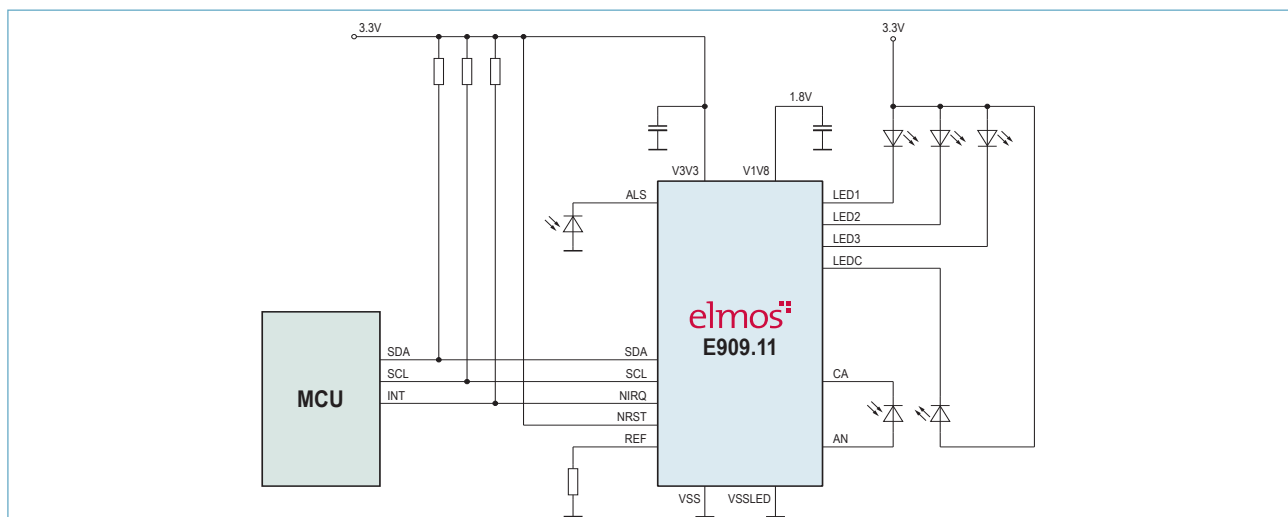

Elmos Semiconductor AG reserves the right to change the detail specifications as may be required to permit improvements in the design of its products.

# Elmos Support 07/2013

## Headquarters

### **Elmos Semiconductor AG**

Heinrich-Hertz-Str. 1  
44227 Dortmund (Germany)  
Phone: +49 (0) 231 / 75 49-100  
Fax: +49 (0) 231 / 75 49-149  
sales-germany@elmos.com  
www.elmos.com

## Regional Sales and Application Support Office Munich

### **Elmos Semiconductor AG**

Am Gefluegelhof 12  
85716 Unterschleißheim/Eching (Germany)  
Phone: +49 (0) 89 / 31 83 70-0  
Fax: +49 (0) 89 / 31 83 70-31  
sales-germany@elmos.com

## Sales and Application Support Office North America

### **Elmos NA. Inc.**

32255 Northwestern Highway, Suite 220  
Farmington Hills, MI 48334 (United States)  
Phone: +1 (0) 248 / 8 65 32 00  
sales-usa@elmosna.com

## Sales and Application Support Office Korea and Japan

### **Elmos Korea**

B-1007, U-Space 2, #670 Daewangpangyo-ro,  
Sampyoung-dong, Bunddang-gu, Sungnam-si  
Kyounggi-do 463-400 Korea  
Phone: +82 (0)31 / 7 14 11 31  
sales-korea@elmos.com

## Sales and Application Support Office China

### **Elmos Semiconductor Technology (Shanghai) Co., Ltd.**

Unit London, 1BF GC Tower,  
No. 1088 YuanShen Road,  
Pudong New District,  
Shanghai, PR China, 200122  
Phone: +86 (0) 21 / 51 78 51 88  
Fax: +86 (0) 21 / 51 78 52 05  
sales-china@elmos.com

## 中国地区销售与应用支持

艾尔默斯半导体技术(上海)有限公司  
中国上海浦东新区源深路1088号  
葛洲坝大厦1B楼伦敦单元, 200122  
电话: +86 (0) 21 / 51 78 51 88  
传真: +86 (0) 21 / 51 78 52 05  
sales-china@elmos.com

## Sales and Application Support Office Singapore

### **Elmos Semiconductor Singapore Pte Ltd.**

3A International Business Park  
#09-13 ICON@IBP  
609935 Singapore  
Phone: +65 (0) 6908 1261  
Fax: +65 (0) 6570 5906  
sales-singapore@elmos.com

Note Elmos Semiconductor AG (below Elmos) reserves the right to make changes to the product contained in this publication without notice. Elmos assumes no responsibility for the use of any circuits described herein, conveys no licence under any patent or other right, and makes no representation that the circuits are free of patent infringement. While the information in this publication has been checked, no responsibility, however, is assumed for inaccuracies. Elmos does not recommend the use of any of its products in life support applications where the failure or malfunction of the product can reasonably be expected to cause failure of a life-support system or to significantly affect its safety or effectiveness. Products are not authorized for use in such applications.

Copyright © 2013 Elmos. Reproduction, in part or whole, without the prior written consent of Elmos, is prohibited.