

FEATURES

- 32-channel, low level current-to-digital converter**
- Up to 24-bit resolution**
- Up to 19.7 kSPS (50.7 μ s integration time)**
- Simultaneous sampling**
- Ultralow noise (down to 0.4 fC [2500e⁻])**
- User-adjustable full-scale range**
- INL: $\pm 0.025\%$ of reading ± 0.75 ppm of FSR**
- Very low power dissipation: 12.5 mW/channel**
- LVDS self-clocked serial data interface**
- SPI configuration registers (daisy-chain)**
- On-board temperature sensor and reference buffer**
- 10 mm \times 10 mm, mini-BGA package**
- Low cost external components**
- Support tools**
 - Evaluation board
 - Reference design with reference layout
 - FPGA Verilog code

APPLICATIONS

- Medical, industrial, and security CT scanner data acquisition
- Photodiode sensors
- Dosimetry and radiation therapy systems
- Optical fiber power monitoring
- X-ray detection systems
- High channel-count data acquisition systems (current or voltage inputs)

GENERAL DESCRIPTION

The [ADAS1126](#) is a 32-channel, current-to-digital, analog-to-digital converter (ADC). It contains 32 low power, low noise, low input current integrators, simultaneous sample-and-holds, and a high speed, high resolution ADCs with configurable sampling rate and resolutions up to 24 bits.

All converted channel results are output on a single LVDS self-clocked serial interface, which reduces external hardware.

An SPI-compatible serial interface allows configuration of the ADC using the SDI input. The SDO output allows the user to daisy-chain several ADCs on a single, 3-wire bus. The [ADAS1126](#) uses the separate supply IOVDD to reduce the digital noise effect on the conversions.

The [ADAS1126](#) is in a 10 mm \times 10 mm, mini-BGA package.

FUNCTIONAL BLOCK DIAGRAM

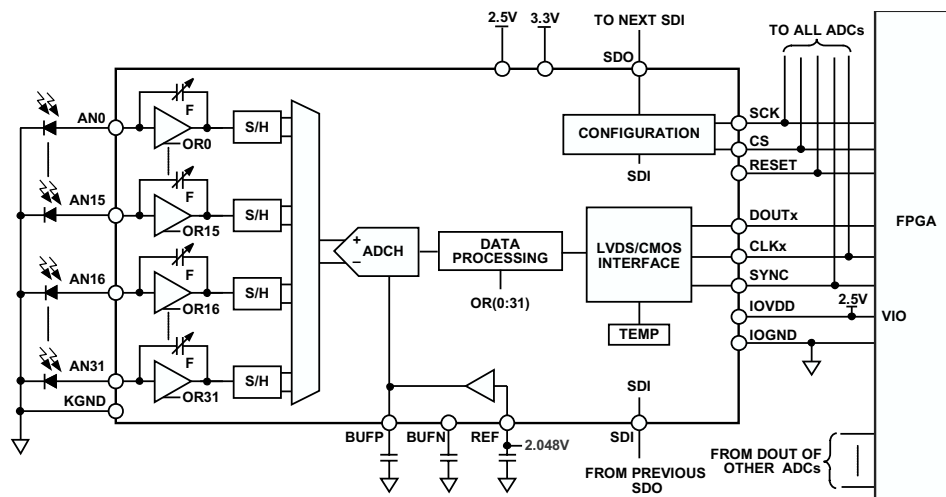

Figure 1.

For more information about the [ADAS1126](#), email: adas@analog.com.

Rev. SpC

[Document Feedback](#)

Information furnished by Analog Devices is believed to be accurate and reliable. However, no responsibility is assumed by Analog Devices for its use, nor for any infringements of patents or other rights of third parties that may result from its use. Specifications subject to change without notice. No license is granted by implication or otherwise under any patent or patent rights of Analog Devices. Trademarks and registered trademarks are the property of their respective owners.

One Technology Way, P.O. Box 9106, Norwood, MA 02062-9106, U.S.A.
 Tel: 781.329.4700 ©2010-2013 Analog Devices, Inc. All rights reserved.
[Technical Support](#) www.analog.com

NOTES