

## AME5296

### ■ General Description

The AME5296 is a high frequency synchronous stepdown DC-DC converter with built internal power MOSFETs. That provides wide 4.5V to 18V input voltage range and 2A continuous load current capability. The AME5296 has synchronous mode operation for higher efficiency over output current load range.

The AME5296 is current mode control scheme which provides fast transient response. Internal compensation function.

### ■ Features

- Wide 4.5V to 18V Operating Input Range
- 100mΩ/40mΩ Low  $R_{DS(ON)}$  internal Power MOSFETs
- Proprietary Switching Loss Reduction Technique
- High Efficiency Synchronous Mode Operation
- Fixed 500KHz Switching Frequency
- External Programmable Soft Start
- OCP and Hiccup
- Thermal Shutdown
- Output Adjustable from 0.8V
- RoHS Compliant and Halogen Free

### ■ Application

- Notebook Systems and I/O Power
- Digital Set Top Boxes
- LCD Display, TV
- Networking, XDSL Modem

### ■ Typical Application

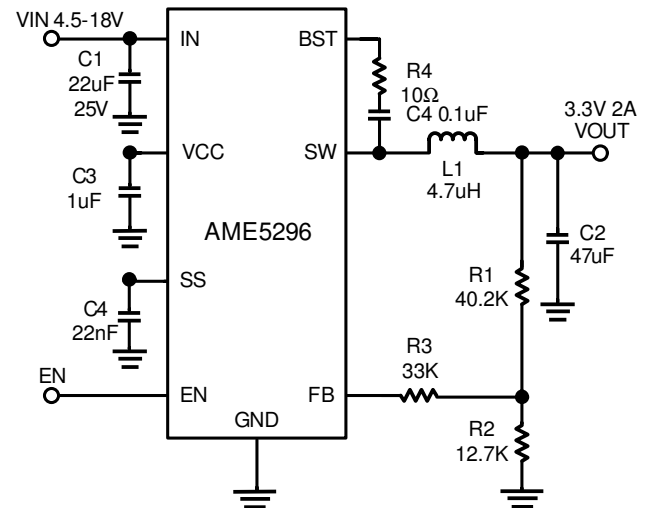

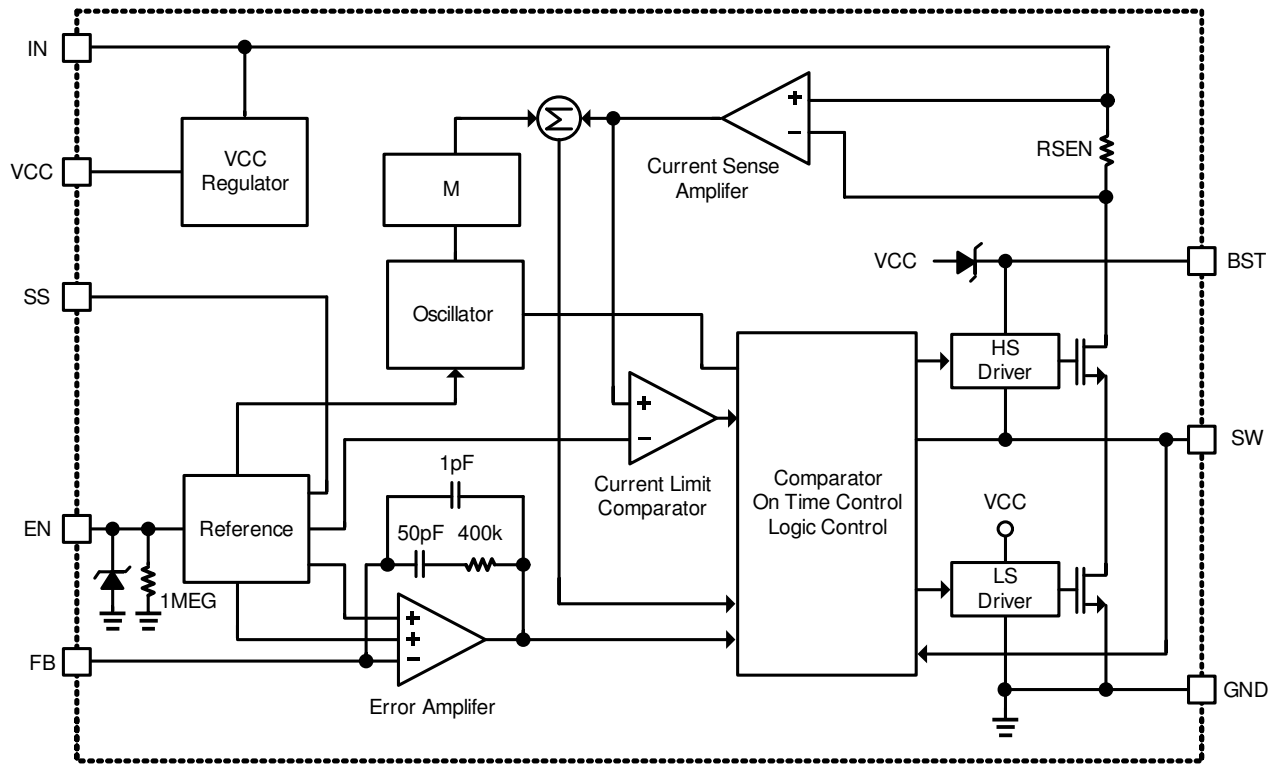
**■ Functional Block Diagram**

### AME5296

### ■ Pin Configuration

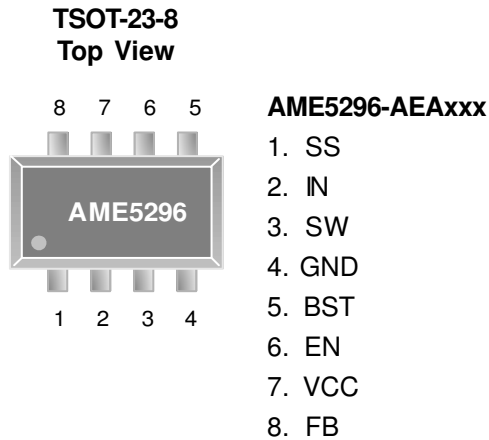

**\* Die Attach:  
Conductive Epoxy**

### ■ Pin Description

Pin No.	Pin Name	Pin Description
1	SS	Soft-Start Control Input. SS controls the soft-start period. Connect a capacitor from SS to GND to set the soft-start period.
2	IN	Supply Voltage. The AME5296 operates from a +4.5V to +18V input rail. C1 is needed to decouple the input rail. Use wide PCB trace to make the connection.
3	SW	Switch Node. Connect this pin to an external L-C filter.
4	GND	System Ground. This pin is the reference ground of the regulated output voltage. For this reason care must be taken in PCB layout. Suggested to be connected to GND with copper and vias.
5	BST	Bootstrap for High Side Gate Driver. Connect a 0.1 $\mu$ F or greater ceramic capacitor from BST to SW pins.
6	EN	EN=1 to enable the AME5296. EN=0 to turn-off the AME5296.
7	VCC	Bias Supply. Decouple with a 0.1 $\mu$ F-to-1 $\mu$ F cap.
8	FB	Feedback Input. It is used to regulate the output of the converter to a set value via an external resistive voltage divider.

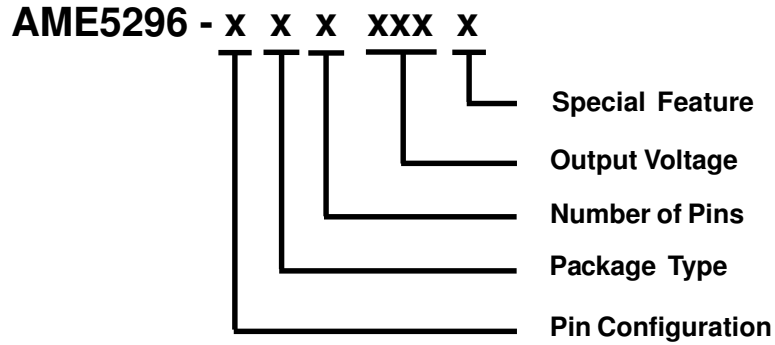
**AME5296**
**■ Ordering Information**

Pin Configuration	Package Type	Number of Pins	Output Voltage	Special Feature
A <small>(TSOT-23-8)</small> 1. SS 2. IN 3. SW 4. GND 5. BST 6. EN 7. VCC 8. FB	E: SOT-2X	A: 8	ADJ: Adjustable	L: TSOT-23-8 (Low Profile)

**AME5296**
**■ Absolute Maximum Ratings**

Parameter	Maximum	Unit
$V_{IN}$	-0.3 to 19	V
$V_{SW}$	-0.3V (-5V for 10ns) to 19V (20V for 5ns)	V
$V_{BST}$	$V_{SW}+6V$	V
All Other Pins	-0.3 to 6.5	V
Junction Temperature	150	°C
Lead Temperature	260	°C
Storage Temperature	-65 to +150	°C

**■ Recommended Operating Conditions**

Parameter	Symbol	Rating	Unit
Input Voltage	$V_{IN}$	4.5V to 18V	V
Output Voltage	$V_{OUT}$	0.8V to $V_{IN}-3V$	
Junction Temperature Range	$T_J$	-40 to +125	°C
Ambient Temperature Range	$T_A$	-40 to +85	

**■ Thermal Information**

Parameter	Package	Die Attach	Symbol	Maximum	Unit
Thermal Resistance* (Junction to Case)	TSOT-23-8	Conductive Epoxy	$\theta_{JC}$	55	°C / W
Thermal Resistance (Junction to Ambient)			$\theta_{JA}$	100	
Internal Power Dissipation			$P_D$	1250	mW
Lead Temperature (Soldering 10sec)**				260	°C

\* Measure  $\theta_{JC}$  on backside center of molding compound if IC has no tab.

\*\* MIL-STD-202G 210F

**■ Electrical Specifications**

$V_{IN}=12V$ , unless otherwise noted. Typical values are at  $T_A=25^{\circ}C$ .

Parameter	Symbol	Test Condition	Min	Typ	Max	Units
Supply Shutdown Current	$I_{IN}$	$V_{EN}=0V$		0.1		$\mu A$
Supply Current	$I_Q$	$V_{EN}=2V, V_{FB}=1V, V_{SS}=3V$		0.7		mA
High Side Switch On-Resistance	$R_{DS(ON)1}$	$V_{BST-SW}=5V$		100		m $\Omega$
Low Side Switch On-Resistance	$R_{DS(ON)2}$	$V_{CC}=5V$		40		m $\Omega$
Load Side Switch Leakage Current	$SW_{LKG}$	$V_{EN}=0V, V_{SW}=12V$		0.15		$\mu A$
Switch Current Limit			2.8			A
Oscillator Frequency	$f_{OSC1}$	$V_{FB}=0.75V$		500		KHz
Fold-back Frequency	$f_{FB}$	$V_{FB}<400mV$		0.25		$f_{SW}$
Maximum Duty Cycle	$D_{MAX}$	$V_{FB}=700mV$	90	95		%
Feedback Voltage	$V_{FB}$	$-40^{\circ}C < T_A < 85^{\circ}C$	-2%	800	2%	mV
Feedback Current	$I_{FB}$	$V_{FB}=800mV$		10	50	nA
EN Rising Threshold	$V_{EN\_RISING}$		1.2	1.4	1.6	V
EN Falling Threshold	$V_{EN\_FALLING}$		1.1	1.25	1.4	V
EN Input Current	$I_{EN}$	$V_{EN}=2V$		2		$\mu A$
		$V_{EN}=0V$		0		$\mu A$
EN Turn Off Delay	$EN_{TD-OFF}$			8		$\mu s$
Input Under Voltage Lockout Threshold	$V_{UVLO}$			3.6		V
Input Under Voltage Lockout Hysteresis	$\Delta V_{UVLO}$			600		mV
$V_{CC}$ Regulator	$V_{CC}$			5		V
$V_{CC}$ Load Regulation		$I_{CC}=5mA$		5		%
Thermal Shutdown	$T_{SD}$			150		$^{\circ}C$
Thermal Hysteresis				20		$^{\circ}C$

## ■ Detailed Description

### Internal $V_{CC}$ Regulator

The internal  $V_{CC}$  regulator is adjusted 5.0V to provide power to the internal circuits from input voltage  $V_{IN}$ . In order to maintain the  $V_{CC}$  voltage stably, a 0.1 $\mu$ F-to-1 $\mu$ F ceramic capacitor is recommended.

### Enable and Soft Start

The EN pin provides electrical on/off control of the regulator. When the EN pin voltage exceeds the lockout threshold voltage, the regulator starts to operate and the soft start begins to charge the external capacitor. If the EN pin voltage is pulled below the lockout threshold voltage, the regulator stops switching and the soft start resets. Connecting the EN pin to ground or to any voltage less than 1.2V will disable the regulator and activate the shutdown mode. To limit the start-up inrush current, a soft-start circuit is used to ramp up the reference voltage from 0V to its final value linearly. The soft start time can be calculated as follows:

$$t_{SS} = \frac{0.8 \times C_{SS}}{I_{SS}}$$

### Under Voltage Lockout (UVLO)

The AME5296 incorporates an under voltage lockout circuit to keep the device disabled when the input voltage  $V_{IN}$  is below the UVLO start threshold voltage. During powering up, the internal circuits are held inactive and the soft start is grounded until the input voltage  $V_{IN}$  exceeds the UVLO start threshold voltage. Once the UVLO start threshold voltage is reached, the soft start is activated and the device begins to operate. The device operates until the input voltage  $V_{IN}$  falls below the UVLO stop threshold voltage. The typical hysteresis in the UVLO comparator is 650mV.

### Thermal Shutdown

The AME5296 protects itself from overheating with an internal thermal shutdown circuit. If the junction temperature exceeds the thermal shutdown threshold, the voltage reference is grounded and the shutdown mode is activated. The AME5296 is restarted under control of the soft start automatically when the junction temperature drops 20°C below the thermal shutdown threshold.

### Over-Current Protection and Hiccup Mode

The over-current limiting is implemented by cycle-by-cycle monitoring the current through the high side MOSFET. If the peak current exceeds the over-current limit threshold, the high side MOSFET is turned off. When the feedback voltage  $V_{FB}$  drops below 0.4V, the oscillator frequency is reduced to about 1/4 of the normal frequency to ensure that the inductor current has more time to decay, thereby preventing runaway. Meanwhile, the AME5296 enters hiccup mode, the average short circuit current is greatly reduced to alleviate the thermal issue and to protect the regulator.

### External Bootstrap Circuit

The external bootstrap circuit contains a capacitor and a resistor. A bootstrap capacitor provides power for the high side MOSFET driver. In order to supply the AC current and maintain the BST-SW voltage stably at the switching condition of the high side MOSFET, a 1 $\mu$ F low ESR ceramic capacitor is recommended. The bootstrap resistor which suggests placing 10 $\Omega$  is utilized to reduce switching spike voltage and noise.

## ■ Application Information

### Inductor Selection

For most applications, the inductance range is chosen based on the desired ripple current. A larger inductance reduces ripple current; meanwhile, the output ripple voltage decreases. Determine inductance is to allow the peak-to-peak ripple current to be approximately 30% of the maximum load current. The inductance value can be calculated by:

$$L = \frac{V_{OUT}}{f \times \Delta I_L} \times \left(1 - \frac{V_{OUT}}{V_{IN}}\right)$$

Where  $f$  is the oscillator frequency,  $V_{IN}$  is the input voltage,  $V_{OUT}$  is the output voltage, and  $\Delta I_L$  is the peak-to-peak inductor ripple current. Choose an inductor that will not saturate under the maximum inductor peak current, calculated by:

$$I_{LPEAK} = I_{LOAD} + \frac{V_{OUT}}{2 \times f \times \Delta I_L} \times \left(1 - \frac{V_{OUT}}{V_{IN}}\right)$$

Where  $I_{LOAD}$  is the load current. The choice of which style inductor to use mainly depends on the price vs. size requirements and any EMI constraints.

### Input Capacitor

The input current to the buck converter is discontinuous; therefore an input capacitor is required to supply the AC current while maintaining the DC input voltage. In order to prevent large voltage drop, a low ESR capacitors is recommended for the best performance. Ceramic capacitors are preferred, but tantalum or low-ESR electrolytic capacitors will also be suggested. Choose X5R or X7R dielectrics when using ceramic capacitors. Since the input capacitor absorbs the input switching current, it requires an adequate ripple current rating. The RMS current in the input capacitor can be estimated by:

$$I_{CIN} = I_{LOAD} \times \sqrt{\frac{V_{OUT}}{V_{IN}} \times \left(1 - \frac{V_{OUT}}{V_{IN}}\right)}$$

At  $V_{IN} = 2V_{OUT}$ , where  $I_{CIN} = I_{LOAD}/2$  is the worst-case condition occurs. For simplification, use an input capacitor with a RMS current rating greater than half of the maximum load current. When using ceramic capacitors, make sure that they have enough capacitance to provide sufficient charge to prevent excessive voltage ripple at input. When using electrolytic or tantalum capacitors, a high quality, small ceramic capacitor, i.e.  $1\mu F$ , should be placed as close to the IC as possible. The input voltage ripple for low ESR capacitors can be estimated by:

$$\Delta V_{IN} = \frac{I_{LOAD}}{C_{IN} \times f} \times \frac{V_{OUT}}{V_{IN}} \times \left(1 - \frac{V_{OUT}}{V_{IN}}\right)$$

Where  $C_{IN}$  is the input capacitance value.

### Output Capacitor

The output capacitor ( $C_{OUT}$ ) is required to maintain the DC output voltage. Ceramic, tantalum, or low ESR electrolytic capacitors are recommended. Low ESR capacitors are preferred to keep the output voltage ripple low. The output voltage ripple can be estimated by:

$$\Delta V_{OUT} = \frac{V_{OUT}}{f \times L} \times \left(1 - \frac{V_{OUT}}{V_{IN}}\right) \times \left(R_{ESR} + \frac{1}{8 \times f \times C_{OUT}}\right)$$

Where  $R_{ESR}$  is the equivalent series resistance (ESR) value of the output capacitor and  $C_{OUT}$  is the output capacitance value.

When using ceramic capacitors, the impedance at the switching frequency is dominated by the capacitance which is the main cause for the output voltage ripple. For simplification, the output voltage ripple can be estimated by:

$$\Delta V_{OUT} = \frac{V_{OUT}}{8 \times f^2 \times L \times C_{OUT}} \times \left(1 - \frac{V_{OUT}}{V_{IN}}\right)$$



### AME5296

When using tantalum or electrolytic capacitors, the ESR dominates the impedance at the switching frequency. For simplification, the output ripple can be approximated to:

$$\Delta V_{OUT} = \frac{V_{OUT}}{f \times L} \times \left( 1 - \frac{V_{OUT}}{V_{IN}} \right) \times R_{ESR}$$

#### Setting the Output Voltage

The output voltage is using a resistive voltage divider connected from the output voltage to feedback pin. It divides the output voltage down to the feedback voltage by the ratio:

$$V_{FB} = V_{OUT} \times \frac{R_2}{R_1 + R_2}$$

The output voltage is:

$$V_{OUT} = 0.8 \times \frac{R_1 + R_2}{R_2}$$

### ■ Typical Application Circuits

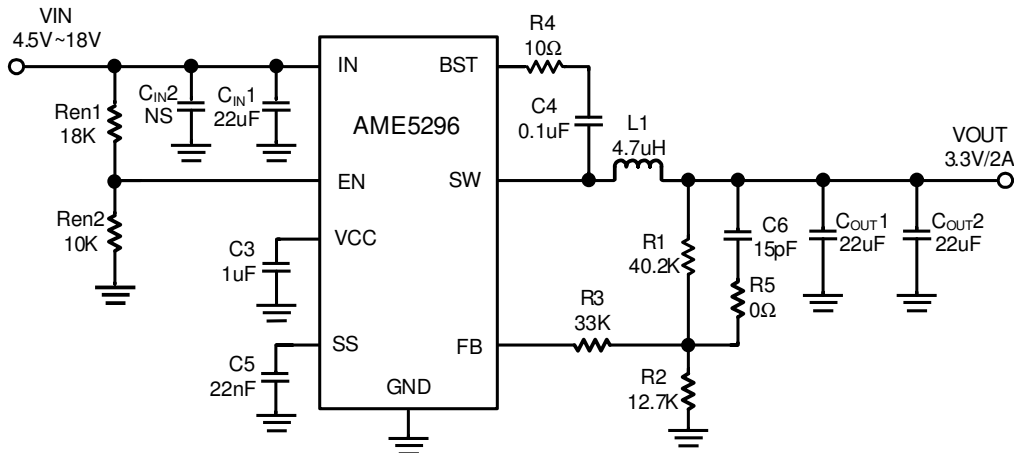

V <sub>OUT</sub> (V)	R1(KΩ)	R2(KΩ)	R3(KΩ)	L(μH)	C <sub>IN</sub> (μF)	C <sub>OUT</sub> (μF)
1.0	20.5	82.0	82	1.5	22	22x2
1.2	30.1	60.4	82	1.5	22	22x2
1.8	40.2	32.4	56	2.2	22	22x2
2.5	40.2	19.1	33	3.3	22	22x2
3.3	40.2	12.7	33	4.7	22	22x2
5.0	40.2	7.68	33	6.8	22	22x2

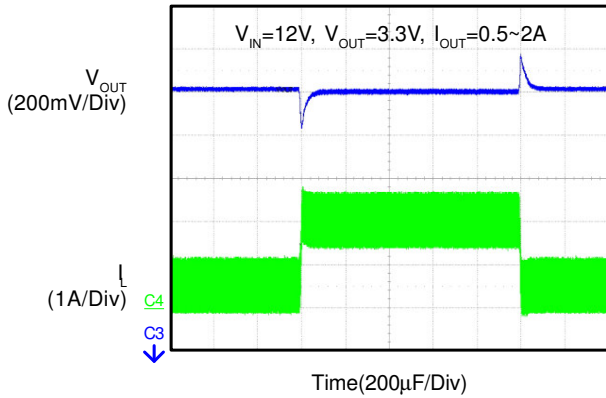
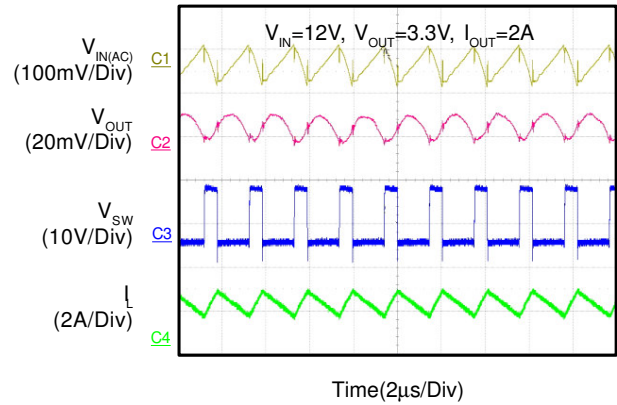
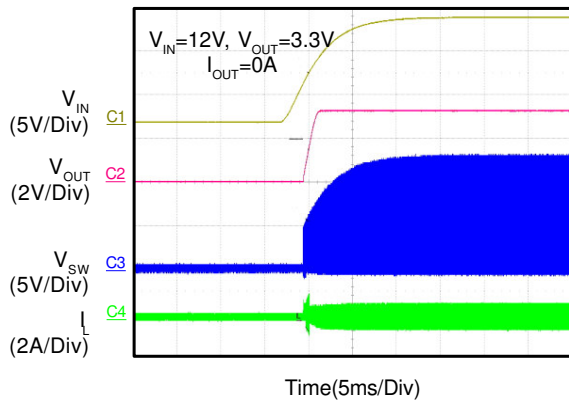
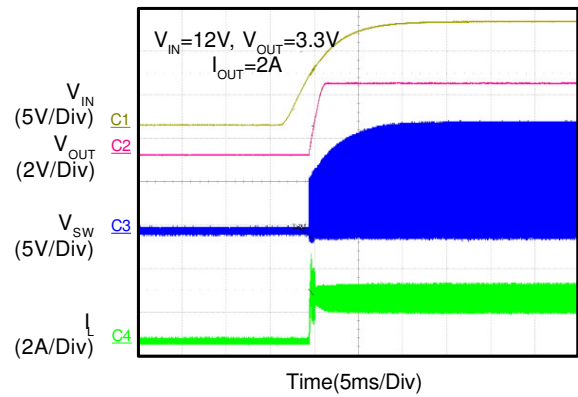
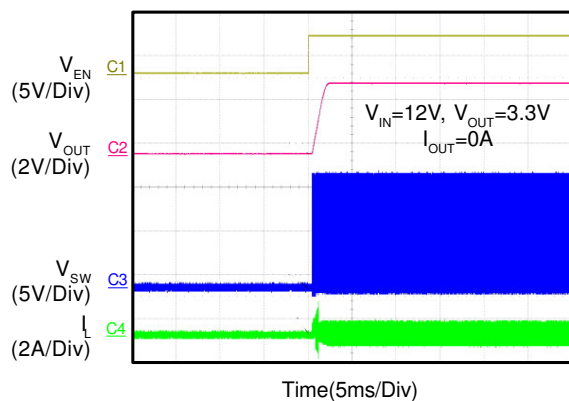
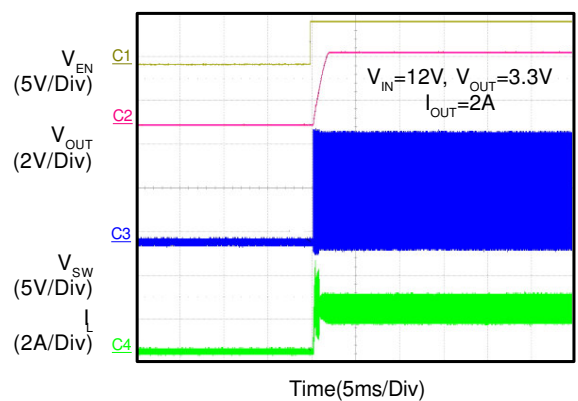
**■ Characterization Curve**
**Load Transient**

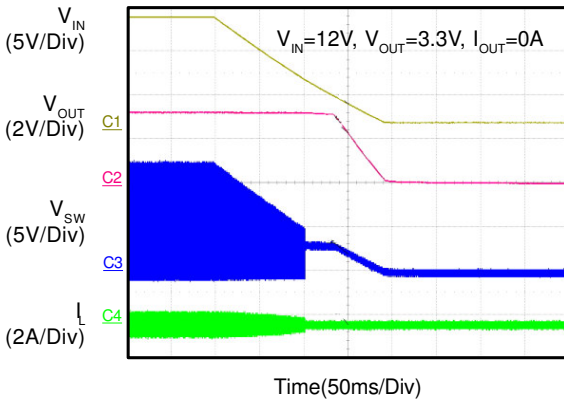
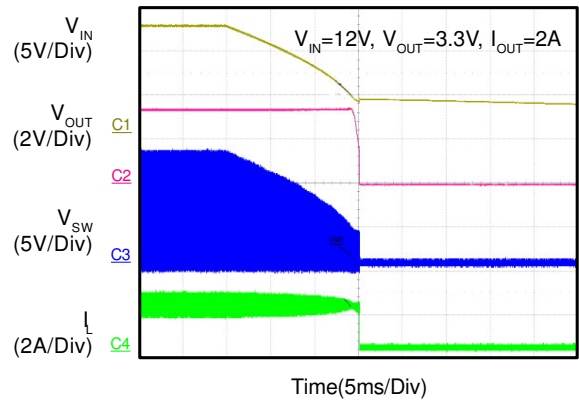
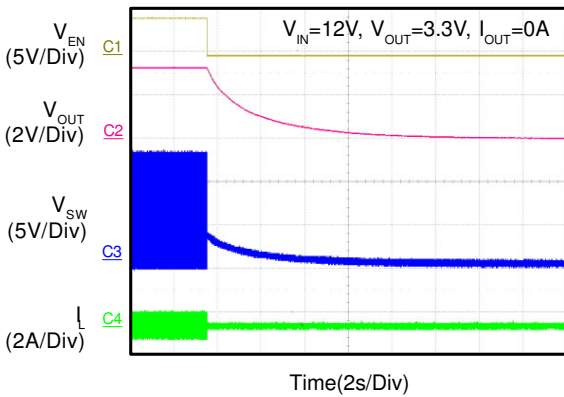
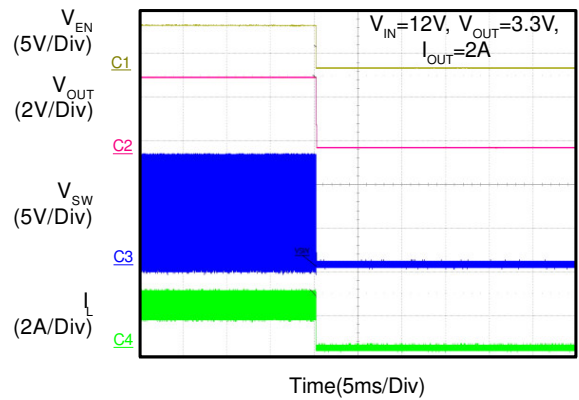
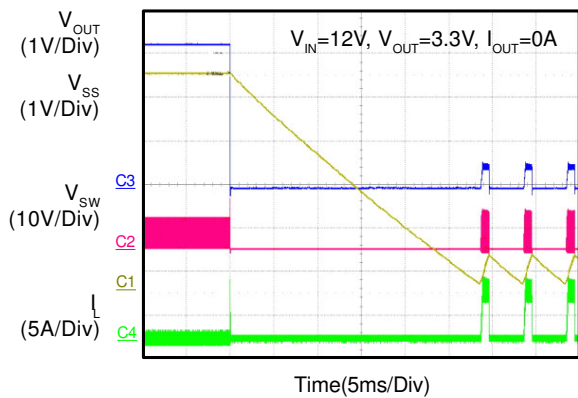
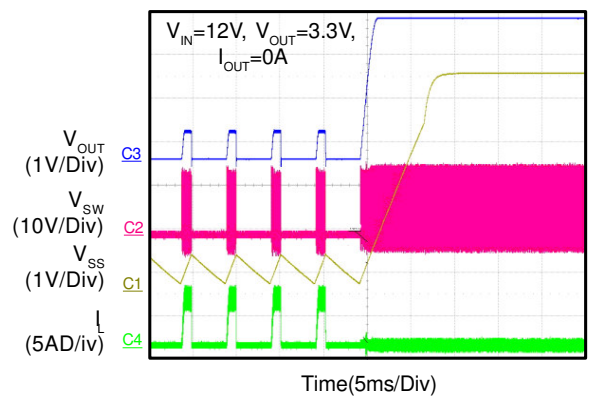
**Output Voltage Ripple**

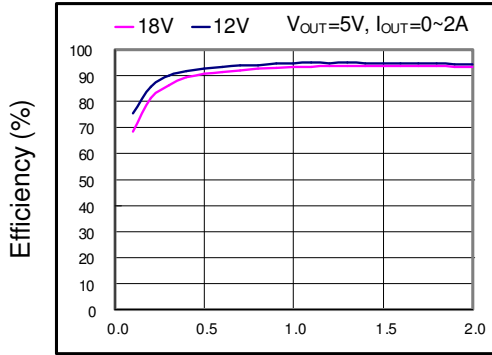
**Power On from Input Voltage**

**Power On from Input Voltage**

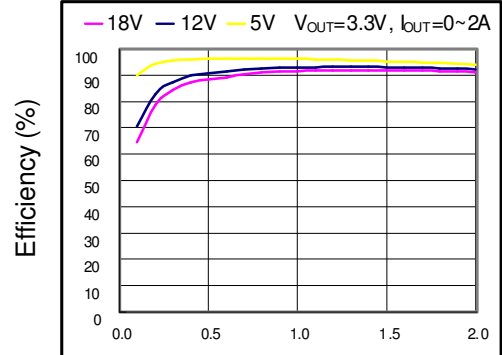
**Power On from EN**

**Power on from EN**

**Power Off from Input Voltage**

**Power Off from Input Voltage**

**Power Off from EN**

**Power Off from EN**

**Short Circuit Entry**

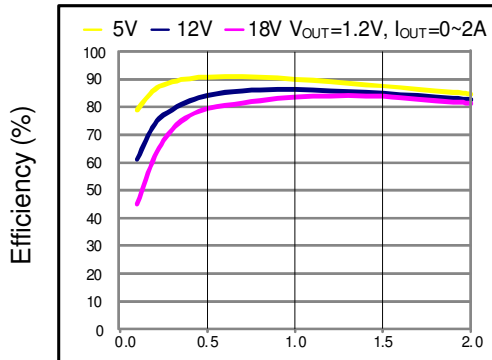
**Short Circuit Recovery**

**Efficiency**

Output Current (A)

**Efficiency**

Output Current (A)

**Efficiency**

Output Current (A)

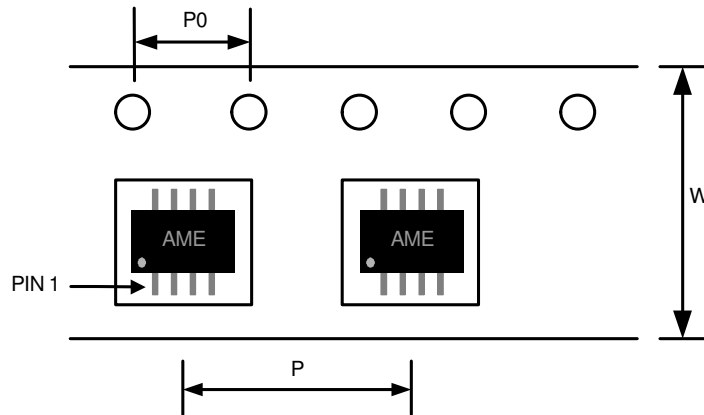
**AME5296**
**■ Tape and Reel Dimension**
**TSOT-23-8**

**Carrier Tape, Number of Components Per Reel and Reel Size**

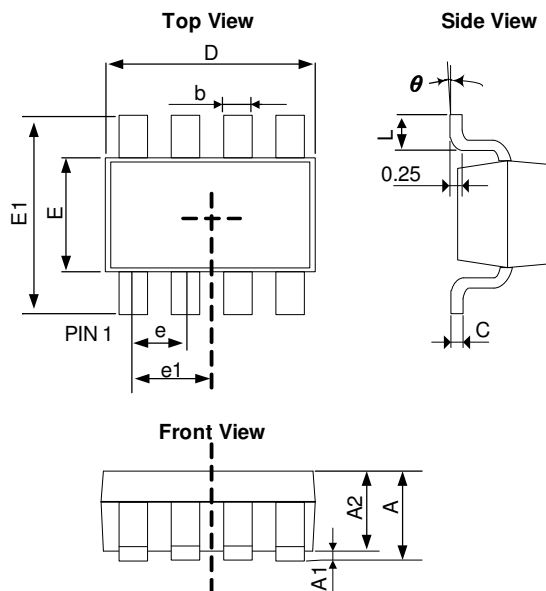
Package	Carrier Width (W)	Pitch (P)	Pitch (P0)	Part Per Full Reel	Reel Size
TSOT-23-8	8.0±0.1 mm	4.0±0.1 mm	4.0±0.1 mm	3000pcs	180±1 mm

**■ Package Dimension**
**TSOT-23-8**

SYMBOLS	MILLIMETERS		INCHES	
	MIN	MAX	MIN	MAX
A	0.70	0.90	0.028	0.035
A1	0.00	0.10	0.000	0.004
A2	0.70	0.80	0.028	0.031
b	0.30	0.50	0.012	0.020
c	0.08	0.20	0.003	0.008
D	2.82	3.02	0.111	0.119
E	1.60	1.70	0.063	0.067
E1	2.65	2.95	0.104	0.116
e	0.65 (BSC)		0.026 (BSC)	
e1	0.975 (BSC)		0.038 (BSC)	
L	0.30	0.60	0.012	0.024
θ	0°	8°	0°	8°



**www.ame.com.tw**  
**E-Mail: sales@ame.com.tw**

Life Support Policy:

These products of AME, Inc. are not authorized for use as critical components in life-support devices or systems, without the express written approval of the president of AME, Inc.

AME, Inc. reserves the right to make changes in the circuitry and specifications of its devices and advises its customers to obtain the latest version of relevant information.

© AME, Inc. , October 2014

Document: A018A-DS5296-A.05

**Corporate Headquarter**  
**AME, Inc.**

8F, 12, WenHu St., Nei-Hu

Taipei 114, Taiwan .

Tel: 886 2 2627-8687

Fax: 886 2 2659-2989