

## WBFBP-02C Plastic-Encapsulate Diodes

### DK400LED02 SWITCHING DIODE

#### DESCRIPTION

Silicon Epitaxial Planar

#### FEATURES

- Small Surface Mounting Type
- High Speed
- High Reliability with High Surge Current Handling Capability

#### APPLICATION

High Speed Switching for Detection

For Portable Equipment:(i.e. Mobile Phone,MP3, MD,CD-ROM, DVD-ROM, Note Book PC, etc.)

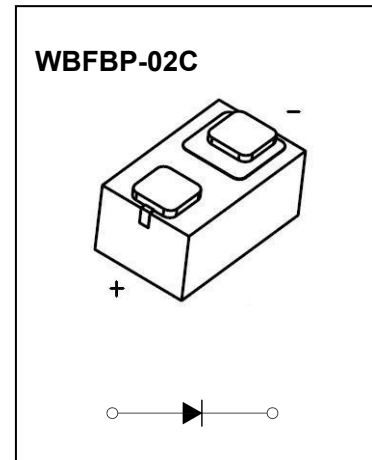

#### MARKING: 7



#### Maximum Ratings and Electrical Characteristics, Single Diode @Ta=25°C

Parameter	Symbol	Value	Unit
Peak Reverse Voltage	$V_{RM}$	90	V
DC Reverse Voltage	$V_R$	80	V
Peak Forward Current	$I_{FM}$	300	mA
Average Rectified Output Current	$I_o$	150	mA
Non-Repetitive Peak Forward Surge Current @t=8.3ms	$I_{FSM}$	2.0	A
Power dissipation	$P_D$	100	mW
Thermal resistance From junction to ambient	$R_{\theta JA}$	1250	°C/W
Junction Temperature	$T_j$	150	°C
Storage Temperature	$T_{STG}$	-55~+150	°C

#### Electrical Ratings @Ta=25°C

Parameter	Symbol	Min	Typ	Max	Unit	Conditions
Forward voltage	$V_F$			1.2	V	$I_F=100mA$
Reverse current	$I_R$			0.1	$\mu A$	$V_R=80V$
Capacitance between terminals	$C_T$			3.0	pF	$V_R=0.5V, f=1MHz$
Reverse recovery time	$t_{rr}$			4	ns	$V_R=6V, I_F=10mA, R_L=100\Omega$

# Typical Characteristics

### Forward Characteristics

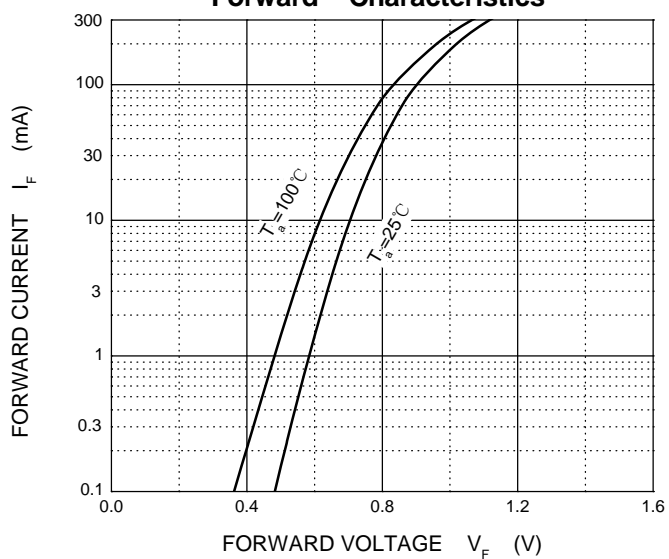

### Reverse Characteristics

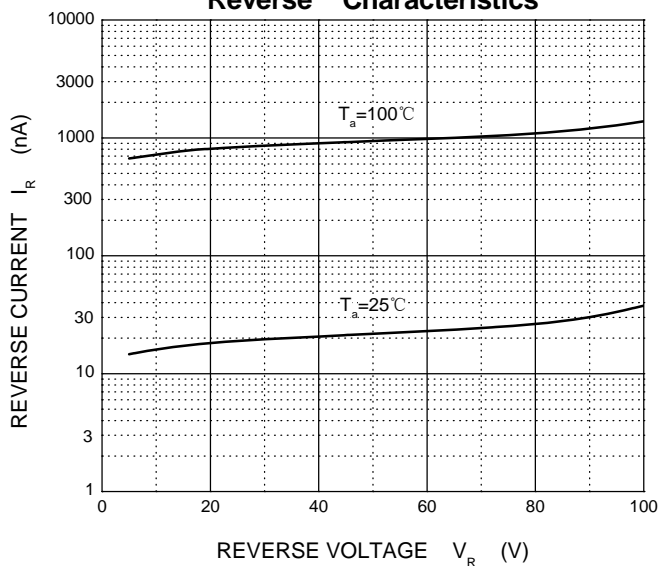

### Capacitance Characteristics

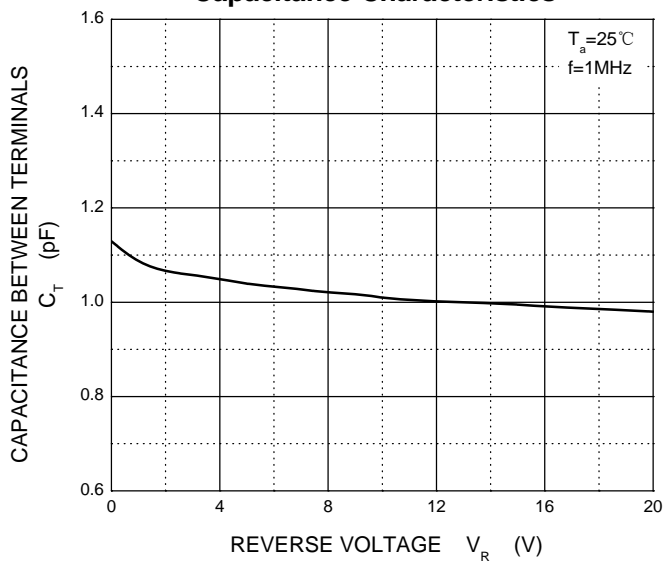

### Power Derating Curve

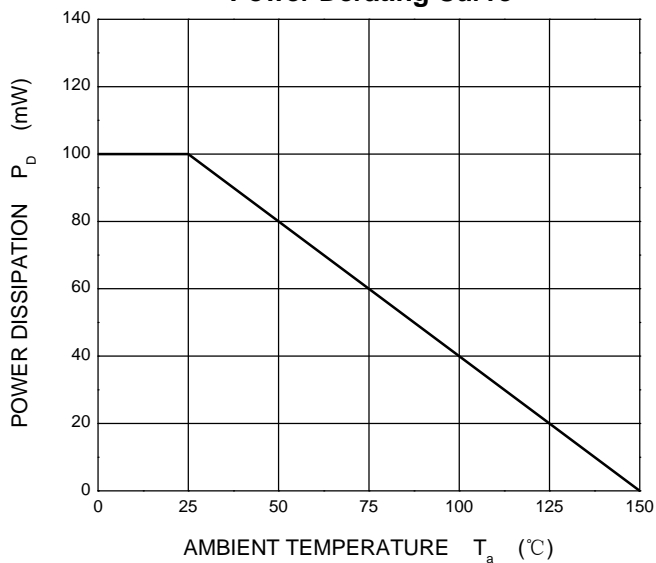

## WBFBP-02C Package Outline Dimensions

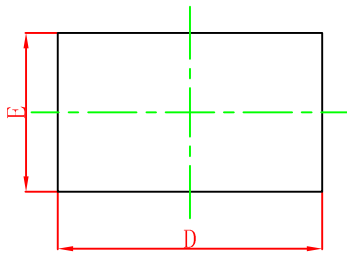

TOP VIEW

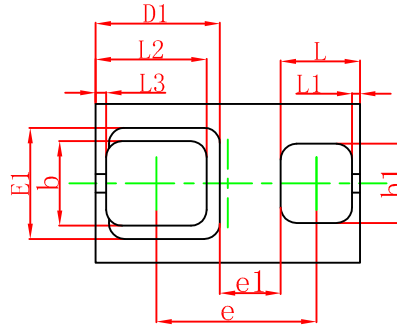

BOTTOM VIEW

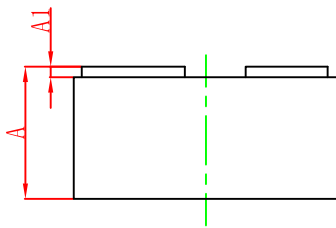

SIDE VIEW

Symbol	Dimensions In Millimeters		Dimensions In Inches	
	Min.	Max.	Min.	Max.
A	0.450	0.550	0.018	0.022
A1	0.010	0.100	0.000	0.004
D	0.950	1.050	0.037	0.041
E	0.550	0.650	0.022	0.026
D1	0.470REF.		0.019REF.	
E1	0.420REF.		0.017REF.	
b	0.270	0.370	0.011	0.015
b1	0.250	0.350	0.010	0.014
e	0.555	0.655	0.022	0.026
e1	0.230REF.		0.009REF.	
L	0.250	0.350	0.010	0.014
L1	0.030REF.		0.001REF.	
L2	0.370	0.470	0.015	0.019
L3	0.040REF.		0.002REF.	

## WBFBP-02C Suggested Pad Layout

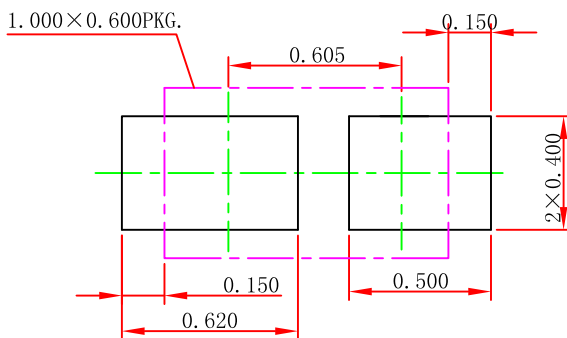

**Note:**

1. Controlling dimension: in millimeters.
2. General tolerance:  $\pm 0.050$ mm.
3. The pad layout is for reference purposes only.

**NOTICE**

JCET reserve the right to make modifications, enhancements, improvements, corrections or other changes without further notice to any product herein. JCET does not assume any liability arising out of the application or use of any product described herein.

# DFN/FBP(1.0X0.6) Tape and Reel

## DFN/FBP(1.0×0.6) Embossed Carrier Tape

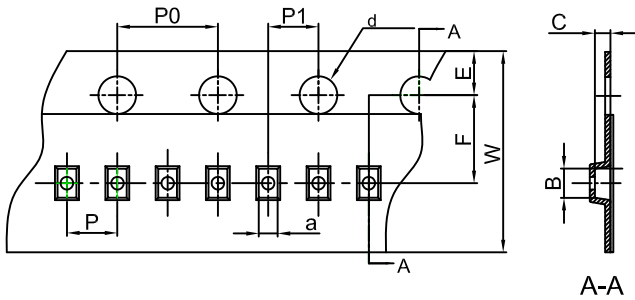

**Packaging Description:**

**DFN/FBP(1.0×0.6)** parts are shipped in tape. The carrier tape is made from a dissipative (carbon filled) polycarbonate resin. The cover tape is a multilayer film (Heat Activated Adhesive in nature) primarily composed of polyester film, adhesive layer, sealant, and anti-static sprayed agent. These reeled parts in standard option are shipped with 10,000 units per 7" or 17.8cm diameter reel. The reels are clear in color and is made of polystyrene plastic (anti-static coated).

Dimensions are in millimeter										
Pkg type	a	B	C	d	E	F	P0	P	P1	W
DFN/FBP(1.0×0.6)	0.66	1.15	0.66	Ø1.50	1.75	3.50	4.00	2.00	2.00	8.00

## DFN/FBP(1.0×0.6) Tape Leader and Trailer

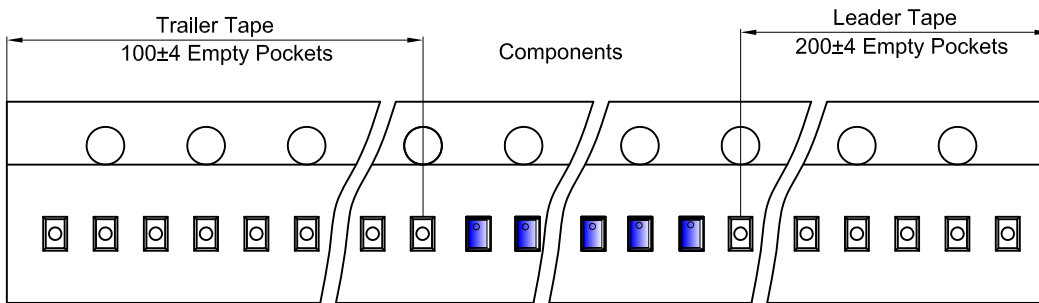

## DFN/FBP(1.0×0.6) Reel

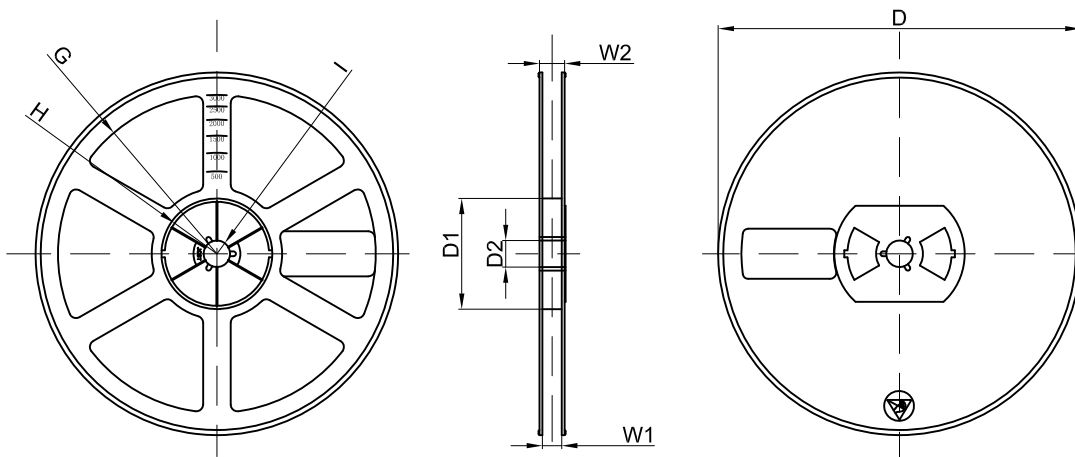

Dimensions are in millimeter								
Reel Option	D	D1	D2	G	H	I	W1	W2
7" Dia	Ø178.00	54.40	13.00	R78.00	R25.60	R6.50	9.50	12.30

REEL	Reel Size	Box	Box Size(mm)	Carton	Carton Size(mm)	G.W.(kg)
10000 pcs	7 inch	150,000 pcs	203×203×195	600,000 pcs	438×438×220	