

Rev	AWO #	Description	Date	Appr
-		RELEASED	12/08/08	

APPROVED: _____
 DATE: _____ TITLE: _____

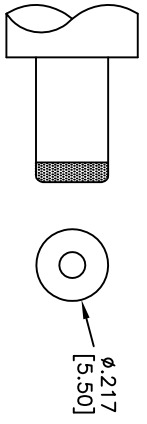
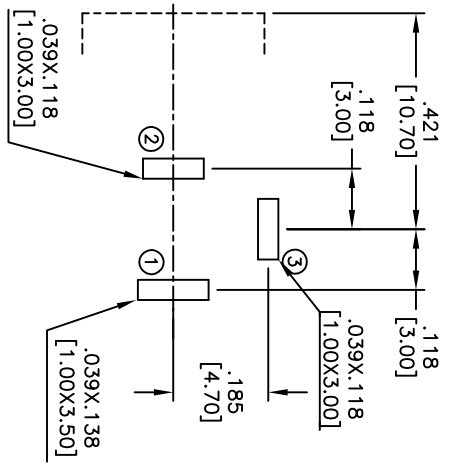
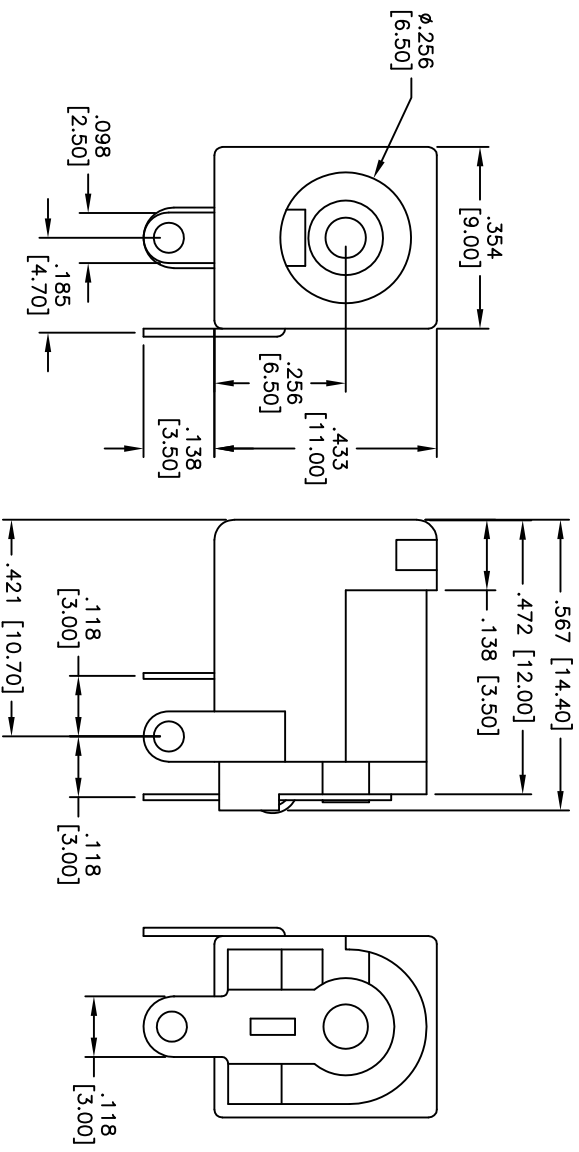

DC MATE PLUG

PART NO.	X
ADC-002G-1-N	$\phi .079$ [2.00]
ADC-002G-2-N	$\phi .098$ [2.50]
ADC-002G-9-N	$\phi .065$ [1.65]

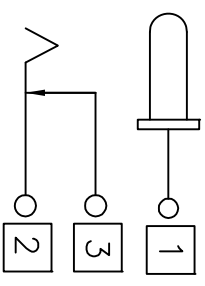

SPECIFICATIONS:
 Material: Insulator: PBT, Glass reinforced, rated UL 94V-0
 Insulator color: Black
 Center Pin: Brass, Nickel plated
 Contacts: Copper Alloy
 Plating: Silver over Nickel underplate
 Electrical:
 Operating voltage: 20 VDC max.
 Current rating: 2.5 Amp max.
 Contact resistance: 30 mohms max. initial
 Insulation resistance: 100 Mohms min.
 Dielectric withstanding voltage: 500 VAC for 1 minute
 Temperature Rating: Operating temperature: -25°C to +70°C
 Environmental:
 Lead free, RoHS compliant
 Recommended soldering temp: 235°C for 5 sec.

UNLESS OTHERWISE SPECIFIED ALL DIMENSIONS ARE INCHES [MM]	
TOLERANCES: EXCEPT AS NOTED	
INCHES	HOLDS
.X ± .10	± .10
.XX ± .020	± .015
.XXX ± .015	± .010
APPROVALS	DATE
DRAWN	DY
CHECKED	
APPROVED	

ADAM TECH
 909 Rahway Avenue, Union, NJ 07083
 Phone: 908-687-5000 Fax: 908-687-5710

TITLE: DC POWER JACK WITH NOTCH
 2.00mm, 2.50mm, 1.65mm CENTER PIN

SIZE	PART NO.	REV.
X	ADC-002G-X-N	-

REF: S0002/C SCALE: NTS SHEET 1 OF 1