



rev 1.0

Low Power, 5V μ P Reset - Active LOW, Push-Pull Output

General Description

The ASM1810 is a voltage supervisor with low-power, 5V μ P active LOW Reset, Push-Pull output. Maximum supply current over temperature is a low 20 μ A.

The ASM1810 generates an active LOW reset signal whenever the monitored supply is out of tolerance. A precision reference and comparator circuit monitor power supply (V_{CC}) level. Tolerance level options are 5%, 10% and 15%. When an out-of-tolerance condition is detected, an internal power-fail signal is generated which forces an active LOW reset signal. After V_{CC} returns to an in-tolerance condition, the reset signal remains active for 150ms to allow the power supply and system microprocessor to stabilize.

The ASM1810 is designed with a push-pull output stage and operates over the extended industrial temperature range. Devices are available in compact surface mount SOT-23 packages and 3-lead TO-92 packages.

Other low power products in this family include the ASM1811/12/15/16/17, ASM1233D and ASM1233M.

Typical Operating Circuit

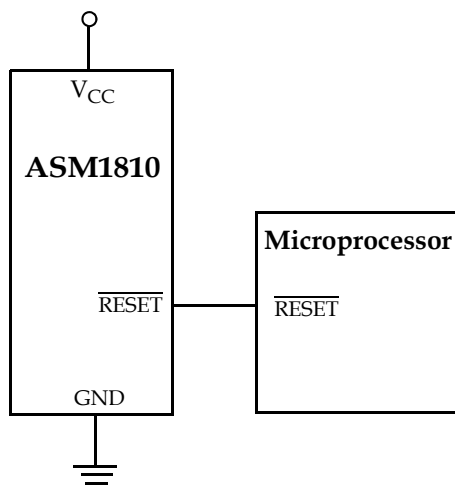

Key Features

- Low Supply Current
• 20 μ A maximum (5.5 V)
- Automatically restarts a microprocessor after power failure
- 150ms reset delay after V_{CC} returns to an in-tolerance condition
- Active LOW power-up reset
- Precision temperature-compensated voltage reference and comparator
- Eliminates external components
- Low-cost TO-92 package
- Compact surface mount SOT-23 package
- Push-Pull output for minimum current drain
- Operating temperature -40°C to +85°C

Applications

- Set-top boxes
- Cellular phones
- PDAs
- Energy management systems
- Embedded control systems
- Printers
- Single board computers

Block Diagram

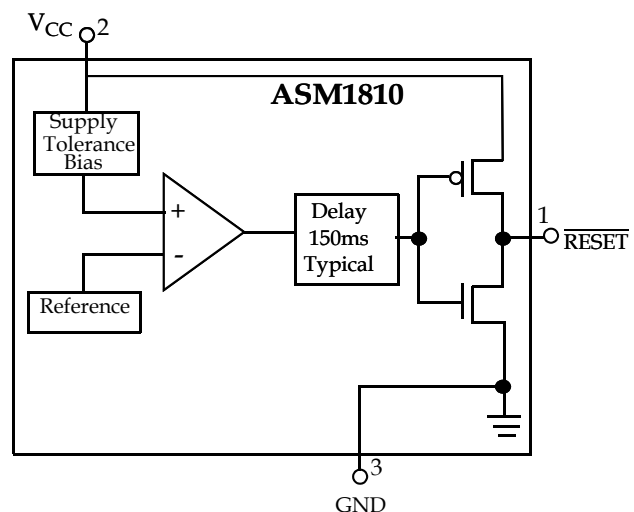



rev 1.0

Pin Configuration

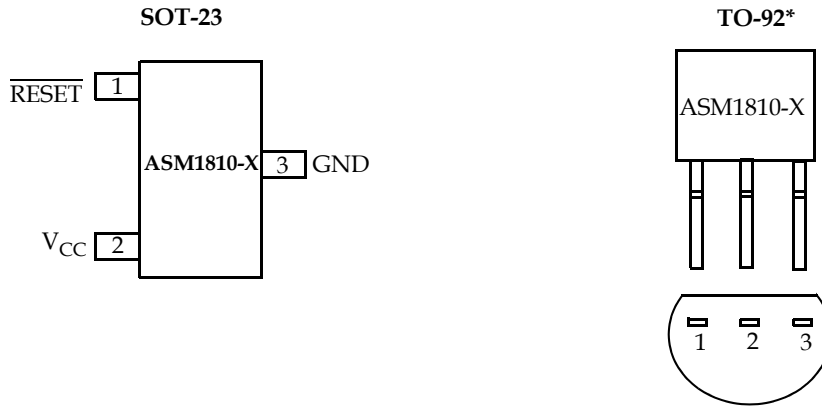

* See Ordering Information

Pin Description

Pin #	Pin Name	Description
1	$\overline{\text{RESET}}$	Active LOW reset output
2	V_{CC}	Power supply input
3	GND	Ground



rev 1.0

Application Information

Operation - Power Monitor

The ASM1810 detects out-of-tolerance power supply conditions. It resets a processor during power-up, power-down and issues a reset to the system processor when the monitored power supply voltage is below the reset threshold. When an out-of-tolerance V_{CC} voltage is detected, the $\overline{\text{RESET}}$ signal is asserted. On power-up, $\overline{\text{RESET}}$ is kept active (LOW) for approximately 150ms after the power supply voltage has reached the selected tolerance. This allows the power supply and microprocessor to stabilize before $\overline{\text{RESET}}$ is released.

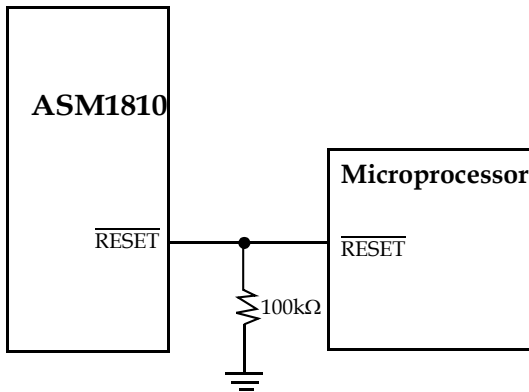

Figure 1: $\overline{\text{RESET}}$ Valid to 0V V_{CC}

Output Conditions

The ASM1810 active LOW reset signal is valid as long as V_{CC} remains below 1.2V. The $\overline{\text{RESET}}$ output on the ASM1810 uses a push-pull drive stage that can maintain a valid output below 1.2V. To sink current with V_{CC} below 1.2V, a resistor can be connected from the reset pin ($\overline{\text{RESET}}$) to Ground (see Figure 1). This configuration will give a valid value on the $\overline{\text{RESET}}$ output with V_{CC} approaching 0V. During both power up and down, this configuration will draw current when the RESET is in the high state. A value of 100kΩ should be adequate to maintain a valid connection.

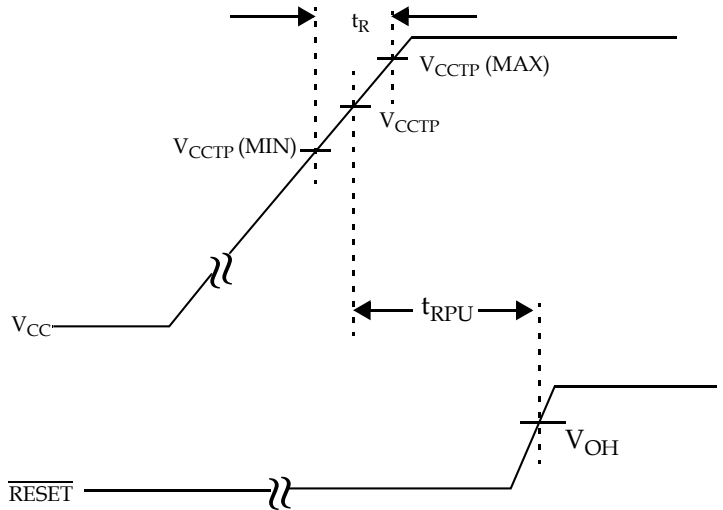

Figure 2: Timing Diagram: Power-Up

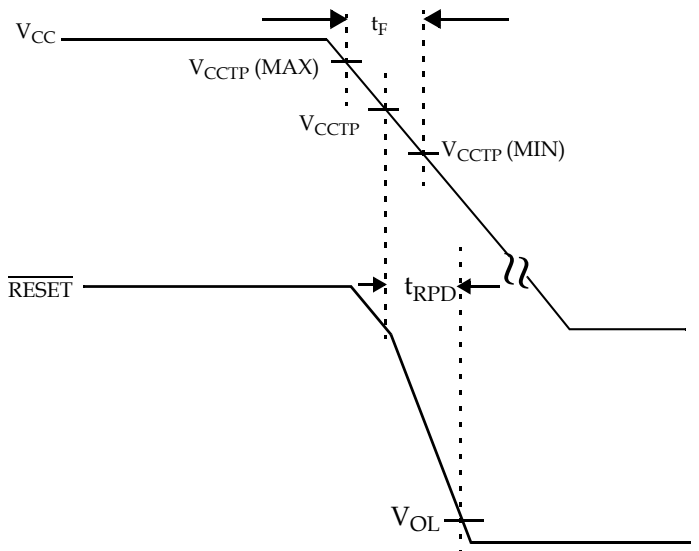

Figure 3: Timing Diagram: Power-Down



Absolute Maximum Ratings

Parameter	Min	Max	Unit
Voltage on V_{CC}	-0.5	7	V
Voltage on \overline{RESET}	-0.5	$V_{CC} + 0.5$	V
Operating Temperature Range	-40	85	°C
Soldering Temperature (for 10 sec)		260	°C
Storage Temperature	-55	125	°C

NOTE: These are stress ratings only and functional use is not implied. Exposure to absolute maximum ratings for prolonged periods of time may affect device reliability.

Electrical Characteristics

Unless otherwise noted $V_{CC} = 1.25V$ to $5.5V$ and specifications are over the operating temperature range of $-40^{\circ}C$ to $+85^{\circ}C$. All voltages are referenced to ground.

Parameter	Symbol	Conditions	Min	Typ	Max	Unit
Supply voltage	V_{CC}		1.2		5.5	V
Output voltage	V_{OH}	$I_{OUT} < 500 \mu A$	$V_{CC} - 0.5V$	$V_{CC} - 0.1V$		V
Output Current	I_{OH}	Output = 2.4V, $V_{CC} \geq 2.7V$		350		μA
Output Current	I_{OL}	Output = 0.4V, $V_{CC} \geq 2.7V$	+10			mA
Operating Current	I_{CC}	$V_{CC} < 5.5V$, \overline{RESET} output open		8	20	μA
V_{CC} Trip Point (ASM1810-5)	V_{CCTP}		4.50	4.62	4.75	V
V_{CC} Trip Point (ASM1810-10)	V_{CCTP}		4.25	4.37	4.49	V
V_{CC} Trip Point (ASM1810-15)	V_{CCTP}		4.00	4.12	4.24	V
Output Capacitance	C_{OUT}				10	pF
V_{CC} Detect to \overline{RESET} Low	t_{RPD}			2	5	μs
V_{CC} Slew Rate (V_{CCTP} (MAX) to V_{CCTP} (MIN))	t_F		300			μs
V_{CC} Slew Rate (V_{CCTP} (MIN) to V_{CCTP} (MAX))	t_R		0			ns
V_{CC} Detect to \overline{RESET} High	t_{RPU}	$t_r = 5\mu s$	100	150	300	ms

Note: The t_F value is for reference in defining values for t_{RPD} and should not be considered for proper operation or use.



rev 1.0

Family Selection Guide

Part #	RESET Voltage (V)	RESET Time (ms)	Output Stage	RESET Polarity
ASM1810	4.620, 4.370, 4.120	150	Push-Pull	LOW
ASM1811	4.620, 4.350, 4.130	150	Open-Drain	LOW
ASM1812	4.620, 4.350, 4.130	150	Push-Pull	HIGH
ASM1815	3.060, 2.880, 2.550	150	Push-Pull	LOW
ASM1816	3.060, 2.880, 2.550	150	Open-Drain	LOW
ASM1817	3.060, 2.880, 2.550	150	Push-Pull	HIGH
ASM1233D	4.625, 4.375, 4.125	350	Open-Drain	LOW
ASM1233M	4.625, 4.375, 2.720	350	Open-Drain	LOW



rev 1.0

Package Dimension

Plastic SOT-23 (3-Pin)

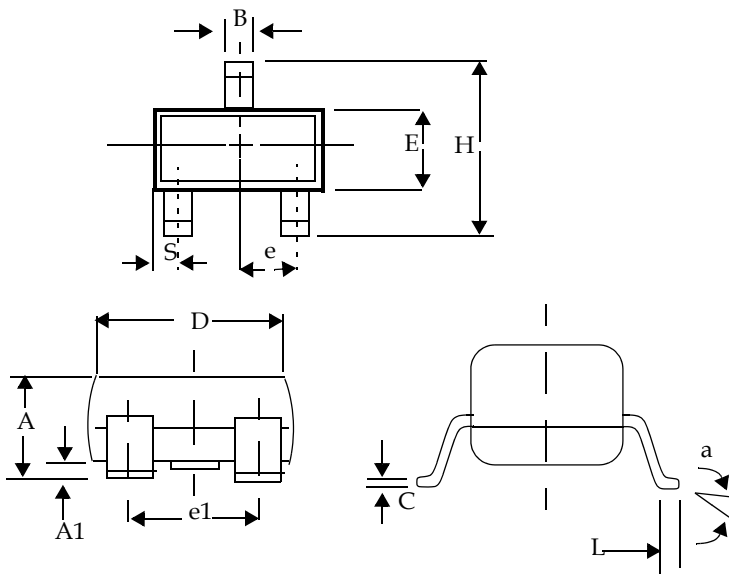

	Inches		Millimeters	
	Min	Max	Min	Max
Plastic SOT-23 (3-Pin)				
A	0.031	0.050	0.80	1.27
A1	0.004	0.010	0.10	0.25
B	0.015	0.020	0.37	0.51
C	0.003	0.007	0.085	0.18
D	0.110	0.120	2.80	3.04
E	0.047	0.055	1.20	1.40
e	0.035	0.040	0.89	1.03
e1	0.070	0.080	1.78	2.05
H	0.083	0.1039	2.10	2.64
L	0.027 REF		0.069 REF	
S	0.018	0.024	0.45	0.60

TO-92 (3-Pin)

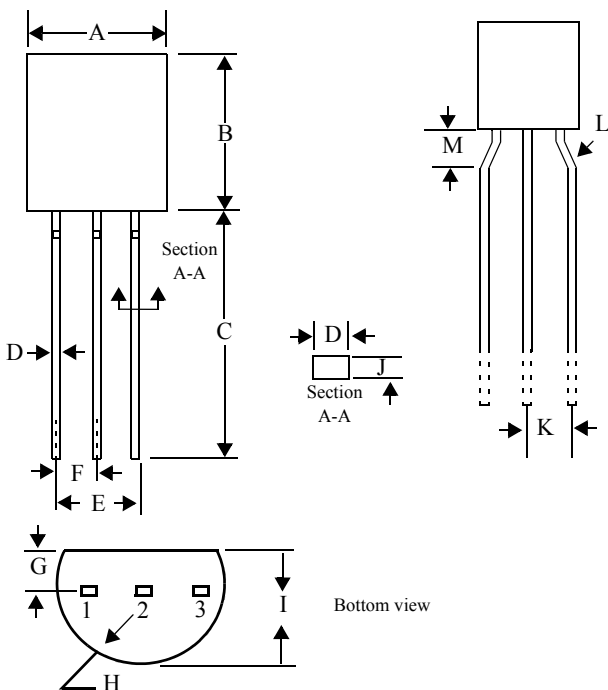

	Inches		Millimeters	
	Min	Max	Min	Max
TO-92 (3-Pin)				
A	0.175	0.195	4.45	4.95
B	0.170	0.192	4.32	4.96
C	0.500	0.610	12.70	15.49
D	0.016	0.022	0.406	0.559
E	0.095	0.105	2.41	2.67
F	0.045	0.060	1.14	1.52
G	0.045	0.060	1.14	1.52
H	0.085	0.095	2.16	2.41
I	0.130	0.155	3.30	3.94
J	0.014	0.020	0.35	0.51
K	0.093	0.115	2.36	2.92
L	45°	60°	45°	60°
M	0.118 Typical		3.00	



rev 1.0

Ordering Information

Device Summary								Package Marking			
Part ** Number	RESET Output Voltage (V)	RESET Tolerance (%)	RESET Time (ms)	Push-Pull Output Stage	TO-92* Package	SOT-23 Package	RESET Polarity	A	B	C	D
ASM1810-5	4.62	5	150	u	u		LOW				
ASM1810-10	4.37	10	150	u	u		LOW				
ASM1810-15	4.12	15	150	u	u		LOW				
ASM1810R-5	4.62	5	150	u		u	LOW	B	A	X	X
ASM1810R-10	4.37	10	150	u		u	LOW	B	B	X	X
ASM1810R-15	4.12	15	150	u		u	LOW	B	C	X	X

* Add /S to Part Number for straight (unformed) leads. (i.e. ASM18xx-x/S)
 ** Add /T to Part Number for Tape and Reel (i.e ASM18xx-x/T)
 XX- Date Code



ASM1810



Alliance Semiconductor Corporation
2575, Augustine Drive,
Santa Clara, CA 95054
Tel: 408 - 855 - 4900
Fax: 408 - 855 - 4999
www.alsc.com

Copyright © Alliance Semiconductor
All Rights Reserved
Part Number: ASM1810
Document Version: 1.0

© Copyright 2003 Alliance Semiconductor Corporation. All rights reserved. Our three-point logo, our name and Intelliwatt are trademarks or registered trademarks of Alliance. All other brand and product names may be the trademarks of their respective companies. Alliance reserves the right to make changes to this document and its products at any time without notice. Alliance assumes no responsibility for any errors that may appear in this document. The data contained herein represents Alliance's best data and/or estimates at the time of issuance. Alliance reserves the right to change or correct this data at any time, without notice. If the product described herein is under development, significant changes to these specifications are possible. The information in this product data sheet is intended to be general descriptive information for potential customers and users, and is not intended to operate as, or provide, any guarantee or warrantee to any user or customer. Alliance does not assume any responsibility or liability arising out of the application or use of any product described herein, and disclaims any express or implied warranties related to the sale and/or use of Alliance products including liability or warranties related to fitness for a particular purpose, merchantability, or infringement of any intellectual property rights, except as express agreed to in Alliance's Terms and Conditions of Sale (which are available from Alliance). All sales of Alliance products are made exclusively according to Alliance's Terms and Conditions of Sale. The purchase of products from Alliance does not convey a license under any patent rights, copyrights; mask works rights, trademarks, or any other intellectual property rights of Alliance or third parties. Alliance does not authorize its products for use as critical components in life-supporting systems where a malfunction or failure may reasonably be expected to result in significant injury to the user, and the inclusion of Alliance products in such life-supporting systems implies that the manufacturer assumes all risk of such use and agrees to indemnify Alliance against all claims arising from such use.