

## Bluetooth<sup>®</sup> low energy wireless network processor

Datasheet - production data

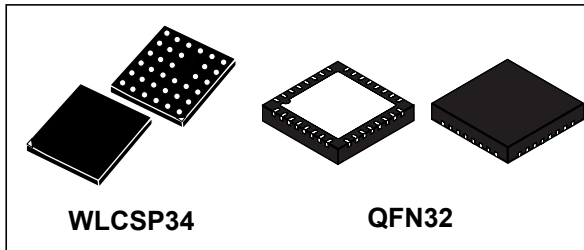

### Features

- Bluetooth specification v4.0 compliant master and slave single-mode Bluetooth low energy network processor
- Embedded Bluetooth low energy protocol stack: GAP, GATT, SM, L2CAP, LL, RF-PHY
- Bluetooth low energy profiles provided separately
- Operating supply voltage: from 2.0 to 3.6 V
- 8.2 mA maximum TX current (@0 dBm, 3.0 V)
- Down to 1.7  $\mu$ A current consumption with active BLE stack
- Integrated linear regulator and DC-DC step-down converter
- Up to +8 dBm available output power (at antenna connector)
- Excellent RF link budget (up to 96 dB)
- Accurate RSSI to allow power control
- Proprietary application controller interface (ACI), SPI based, allows interfacing with an external host application microcontroller
- Full link controller and host security
- High performance, ultra-low power Cortex-M0 32-bit based architecture core
- On-chip non-volatile Flash memory
- AES security co-processor
- Low power modes
- 16 or 32 MHz crystal oscillator
- 12 MHz ring oscillator
- 32 kHz crystal oscillator
- 32 kHz ring oscillator
- Battery voltage monitor and temperature sensor
- Compliant with the following radio frequency regulations: ETSI EN 300 328, EN 300 440, FCC CFR47 Part 15, ARIB STD-T66
- Available in QFN32 (5 x 5 mm) and WLCSP34 (2.66 x 2.56 mm) packages
- Operating temperature range: -40 °C to 85 °C

### Applications

- Watches
- Fitness, wellness and sports
- Consumer medical
- Security/proximity
- Remote control
- Home and industrial automation
- Assisted living
- Mobile phone peripherals
- PC peripherals

**Table 1. Device summary**

Order code	Package	Packing
BLUENRGQTR	QFN32 (5 x 5 mm)	Tape and reel
BLUENRGCSF	WLCSP34 (2.66 x 2.56 mm)	Tape and reel

# Contents

- 1 Description . . . . . 6**
- 2 General description . . . . . 7**
- 3 Pin description . . . . . 9**
- 4 Application circuits . . . . . 12**
- 5 Absolute maximum ratings and thermal data . . . . . 16**
- 6 General characteristics . . . . . 17**
- 7 Electrical specification . . . . . 18**
  - 7.1 Electrical characteristics . . . . . 18
  - 7.2 RF general characteristics . . . . . 20
  - 7.3 RF transmitter characteristics . . . . . 21
  - 7.4 RF receiver characteristics . . . . . 22
  - 7.5 High speed crystal oscillator (HSXOSC) characteristics . . . . . 23
    - 7.5.1 High speed crystal oscillator (HSXOSC) . . . . . 23
  - 7.6 Low speed crystal oscillator (LSXOSC) characteristics . . . . . 25
  - 7.7 High speed ring oscillator (HSROSC) characteristics . . . . . 25
  - 7.8 Low speed ring oscillator (LSROSC) characteristics . . . . . 25
  - 7.9 N-fractional frequency synthesizer characteristics . . . . . 25
  - 7.10 Auxiliary blocks characteristics . . . . . 26
- 8 Block diagram and descriptions . . . . . 27**
  - 8.1 Core, memory and peripherals . . . . . 27
  - 8.2 Power management . . . . . 28
  - 8.3 Clock management . . . . . 30
  - 8.4 Bluetooth low energy radio . . . . . 30
- 9 Operating modes . . . . . 31**
- 10 Application controller interface . . . . . 34**

11	Package mechanical data .....	35
12	PCB assembly guidelines .....	40
13	Revision history .....	42

## List of tables

Table 1.	Device summary . . . . .	1
Table 2.	Pinout description . . . . .	10
Table 3.	External component list. . . . .	14
Table 4.	Absolute maximum ratings . . . . .	16
Table 5.	Thermal data. . . . .	16
Table 6.	Recommended operating conditions . . . . .	17
Table 7.	Electrical characteristics . . . . .	18
Table 8.	RF general characteristics . . . . .	20
Table 9.	RF Transmitter characteristics . . . . .	21
Table 10.	RF receiver characteristics . . . . .	22
Table 11.	High speed crystal oscillator characteristics . . . . .	23
Table 12.	Low speed crystal oscillator characteristics . . . . .	25
Table 13.	High speed ring oscillator characteristics . . . . .	25
Table 14.	Low speed ring oscillator characteristics . . . . .	25
Table 15.	N-fractional frequency synthesizer characteristics . . . . .	26
Table 16.	Auxiliary blocks characteristics . . . . .	26
Table 17.	SPI interface . . . . .	28
Table 18.	BlueNRG operating modes. . . . .	32
Table 19.	BlueNRG transition times . . . . .	33
Table 20.	QFN32 (5 x 5 x 1 pitch 0.5 mm) mechanical data. . . . .	37
Table 21.	WLCSP34 (2.66 x 2.56 x 0.5 pitch 0.4 mm) mechanical data . . . . .	39
Table 22.	Flip Chip CSP (2.66 x 2.56 x 0.5 pitch 0.4 mm) package reflow profile recommendation . . . . .	40
Table 23.	Document revision history. . . . .	42

## List of figures

Figure 1.	BlueNRG application block diagram . . . . .	8
Figure 2.	BlueNRG pinout top view (QFN32). . . . .	9
Figure 3.	BlueNRG pinout top view (WLCSP34) . . . . .	9
Figure 4.	BlueNRG pinout bottom view (WLCSP34) . . . . .	10
Figure 5.	BlueNRG application circuit: active DC-DC converter QFN32 package . . . . .	12
Figure 6.	BlueNRG application circuit: non active DC-DC converter QFN32 package . . . . .	13
Figure 7.	BlueNRG application circuit: active DC-DC converter WLCSP package . . . . .	13
Figure 8.	BlueNRG application circuit: non active DC-DC converter WLCSP package. . . . .	14
Figure 9.	Simplified block diagram of the amplitude regulated oscillator . . . . .	24
Figure 10.	BlueNRG block diagram . . . . .	27
Figure 11.	Power management strategy using LDO . . . . .	29
Figure 12.	Power management strategy using step-down DC-DC converter . . . . .	29
Figure 13.	Simplified state machine . . . . .	32
Figure 14.	QFN32 (5 x 5 x 1 pitch 0.5 mm) drawing . . . . .	36
Figure 15.	WLCSP34 (2.66 x 2.56 x 0.5 pitch 0.4 mm) drawing . . . . .	38
Figure 16.	Flip Chip CSP (2.66 x 2.56 x 0.5 pitch 0.4 mm) package reflow profile recommendation . . . . .	40

# 1 Description

The BlueNRG is a very low power Bluetooth low energy (BLE) single-mode network processor, compliant with Bluetooth specification v4.0. The BlueNRG can act as master or slave. The entire Bluetooth low energy stack runs on the embedded Cortex M0 core. The non-volatile Flash memory allows on-field stack upgrading. The BlueNRG allows applications to meet of the tight advisable peak current requirements imposed with the use of standard coin cell batteries. The maximum peak current is only 10 mA at 1 dBm of output power. Ultra low-power sleep modes and very short transition times between operating modes allow very low average current consumption, resulting in longer battery life. The BlueNRG offers the option of interfacing with external microcontrollers using SPI transport layer.

## 2 General description

The BlueNRG is a single-mode Bluetooth low energy master/slave network processor, compliant with the Bluetooth specification v4.0.

It integrates a 2.4 GHz RF transceiver and a powerful Cortex-M0 microcontroller, on which a complete power-optimized stack for Bluetooth single mode protocol runs, providing:

- full master and slave role support
- GAP: central, peripheral, observer or broadcaster roles
- ATT/GATT: client and server
- SM: privacy, authentication and authorization
- L2CAP
- Link Layer: AES-128 encryption and decryption

An on-chip non-volatile Flash memory allows on-field Bluetooth low energy stack upgrade.

The BlueNRG is equipped with Bluetooth low energy profiles in C source code.

The device allows applications to meet of the tight advisable peak current requirements imposed with the use of standard coin cell batteries. If the high efficiency embedded DC-DC step-down converter is used, the maximum input current is only 15 mA at the highest output power (+8 dBm). Even if the DC-DC converter is not used, the maximum input current is only 29 mA at the highest output power, still preserving battery life.

Ultra low-power sleep modes and very short transition time between operating modes result in very low average current consumption during real operating conditions, providing very long battery life.

Two different external matching networks are suggested: standard mode (TX output power up to +5 dBm) and high power mode (TX output power up to +8 dBm).

The external host application processor, where the application resides, is interfaced with the BlueNRG through an application controller interface protocol which is based on a standard SPI interface.

Figure 1. BlueNRG application block diagram

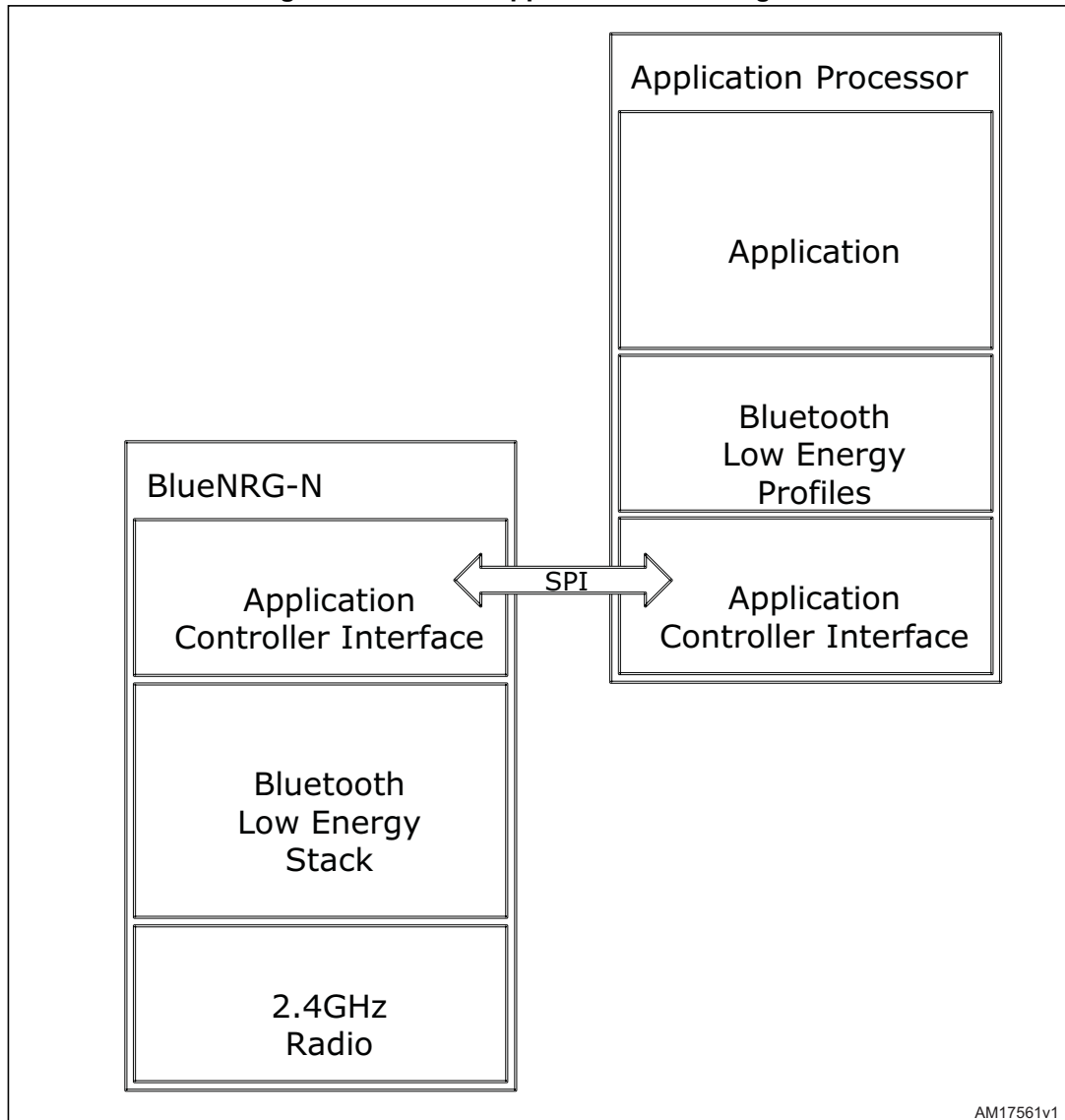

AM17561v1



### 3 Pin description

The BlueNRG pinout is shown in *Figure 2*, *Figure 3* and *Figure 4*. In *Table 2* a short description of the pins is provided.

**Figure 2. BlueNRG pinout top view (QFN32)**

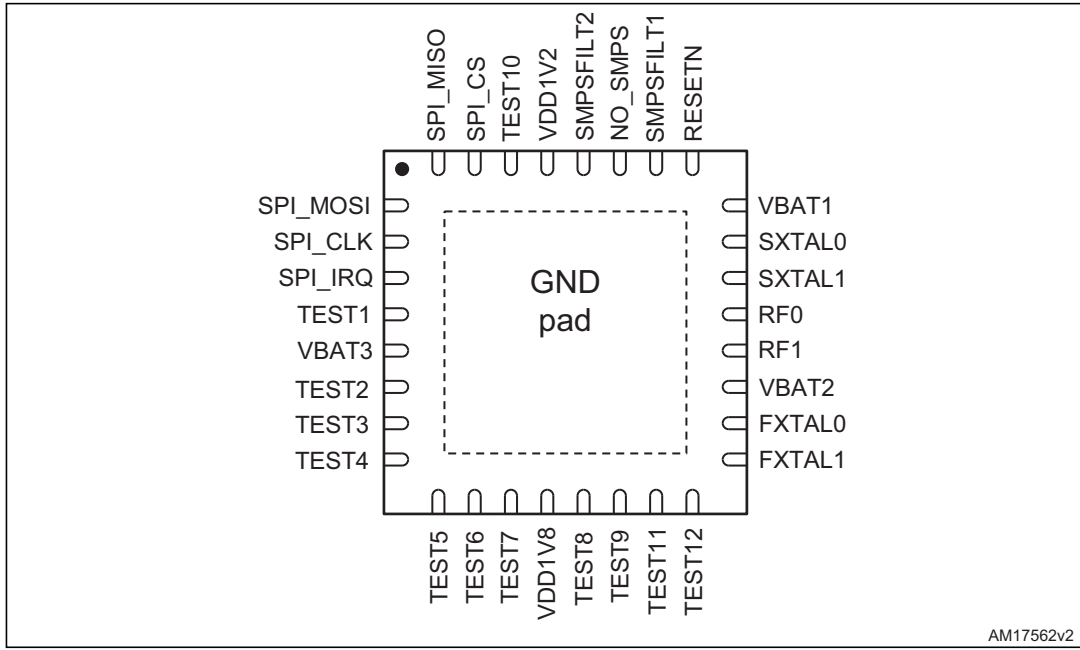

**Figure 3. BlueNRG pinout top view (WLCSP34)**

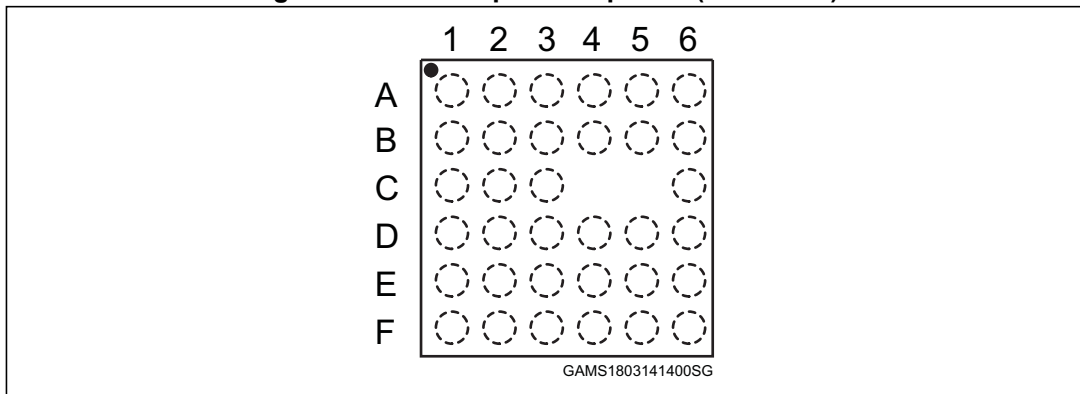

Note: Top view (balls are underneath).

Figure 4. BlueNRG pinout bottom view (WLCSP34)

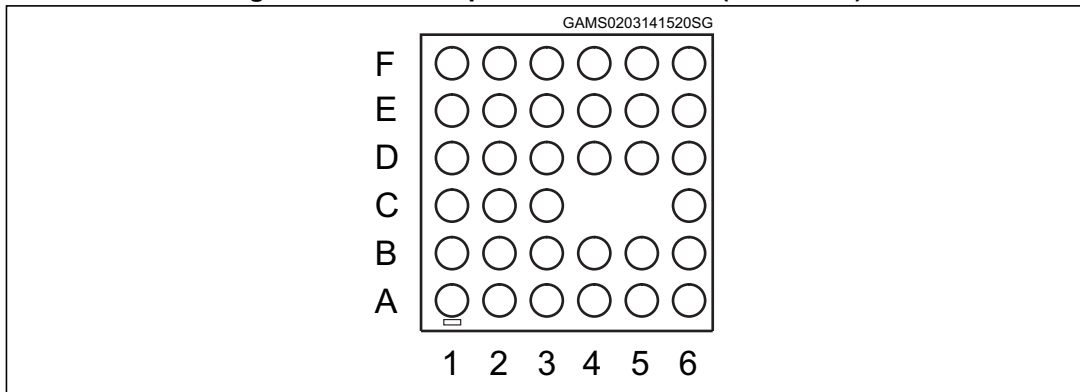

Table 2. Pinout description

Pins		Name	I/O	Description
QFN32	WLCSP			
1	E2	SPI_MOSI	I	SPI_MOSI
2	E1	SPI_CLK	I	SPI_CLK
3	D2	SPI_IRQ	O	SPI_IRQ
4	D1	TEST1	I/O	Test pin
5	C1	VBAT3	VDD	2.0-3.6 battery voltage input
6	C2	TEST2	I/O	Test pin connected to GND
7	B1	TEST3	I/O	Test pin connected to GND
8	B2	TEST4	I/O	Test pin connected to GND
9	A1	TEST5	I/O	Test pin connected to GND
10	B3	TEST6	I/O	Test pin connected to GND
11	A2	TEST7	I/O	Test pin connected to GND
12	A3	VDD1V8	O	1.8 V Digital core
13	A4	TEST8	I/O	Test pin not connected
14	A5	TEST9	I/O	Test pin not connected
15	B4	TEST11	I/O	Test pin not connected (QFN32) Test pin connected to GND (WLCSP)
16	B5	TEST12	I/O	Test pin not connected (QFN32) Test pin connected to GND (WLCSP)
17	A6	FXTAL1	I	16/32 MHz crystal
18	B6	FXTAL0	I	16/32 MHz crystal
19	-	VBAT2	VDD	2.0-3.6 battery voltage input
20	C6	RF1	I/O	Antenna + matching circuit
21	D6	RF0	I/O	Antenna + matching circuit
22	E6	SXTAL1	I	32 kHz Crystal

Table 2. Pinout description (continued)

Pins		Name	I/O	Description
QFN32	WLCSP			
23	E5	SXTAL0	I	32 kHz Crystal
24	D5	VBAT1	VDD	2.0-3.6 battery voltage input
25	E4	RESETN	I	Reset and deep sleep control
26	F6	SMPSFILT1	O	SMPS output
27	-	NO_SMPS	I	Power management strategy selection
28	F5	SMPSFILT2	I/O	SMPS input/output
29	F3	VDD1V2	O	1.2 V digital core
30	E3	TEST10	I/O	TEST pin connected to GND
31	F2	SPI_CS	I	SPI_CS
32	F1	SPI_MISO	O	SPI_MISO
-	C3	GND	GND	Ground
-	D3	GND	GND	Ground
-	D4	GND	GND	Ground
-	F4	SMPS-GND	GND	SMPS ground

# 4 Application circuits

The schematics below are purely indicative. For more detailed schematics, please refer to the "Reference design" and "Layout guidelines" which are provided as separate documents.

**Figure 5. BlueNRG application circuit: active DC-DC converter QFN32 package**

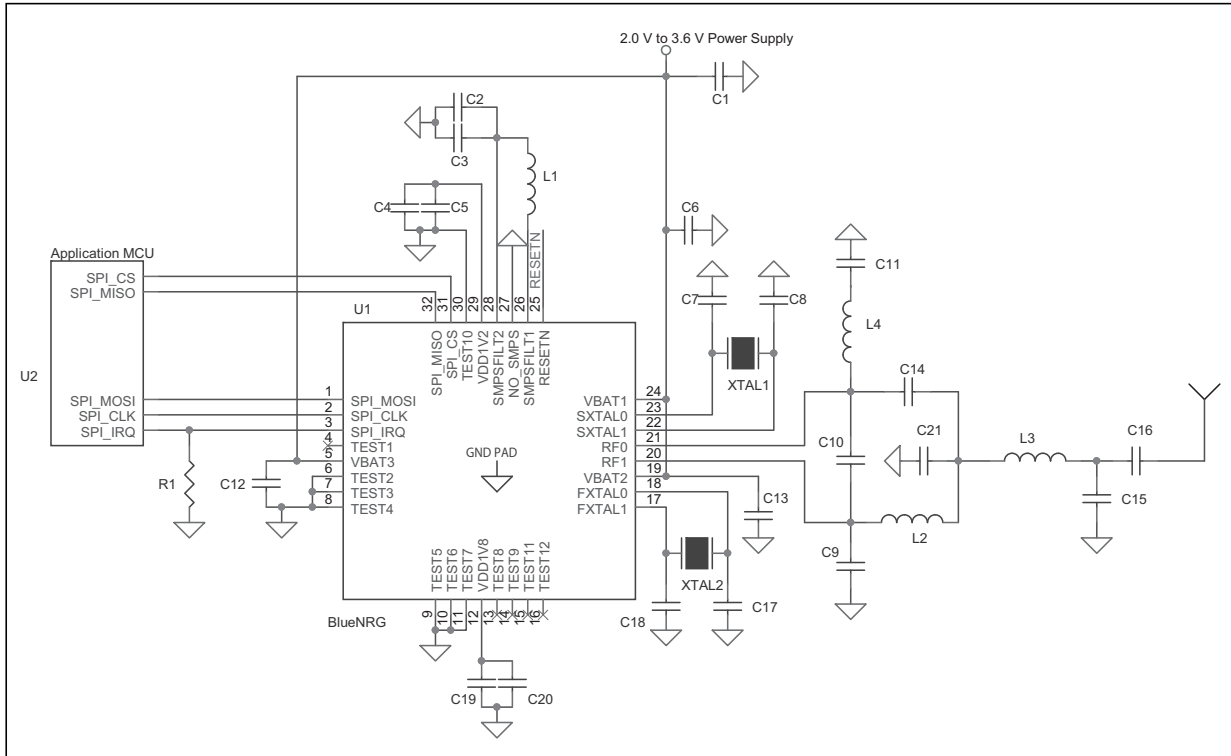

Figure 6. BlueNRG application circuit: non active DC-DC converter QFN32 package

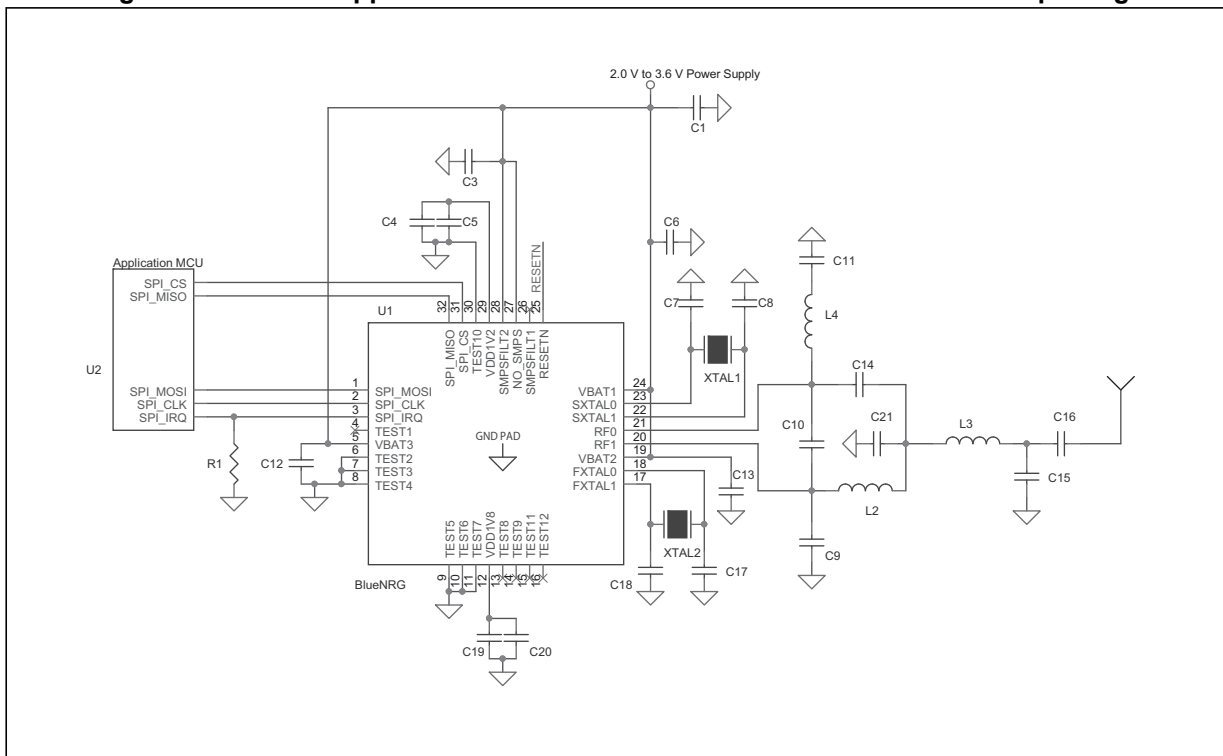

Figure 7. BlueNRG application circuit: active DC-DC converter WLCSP package

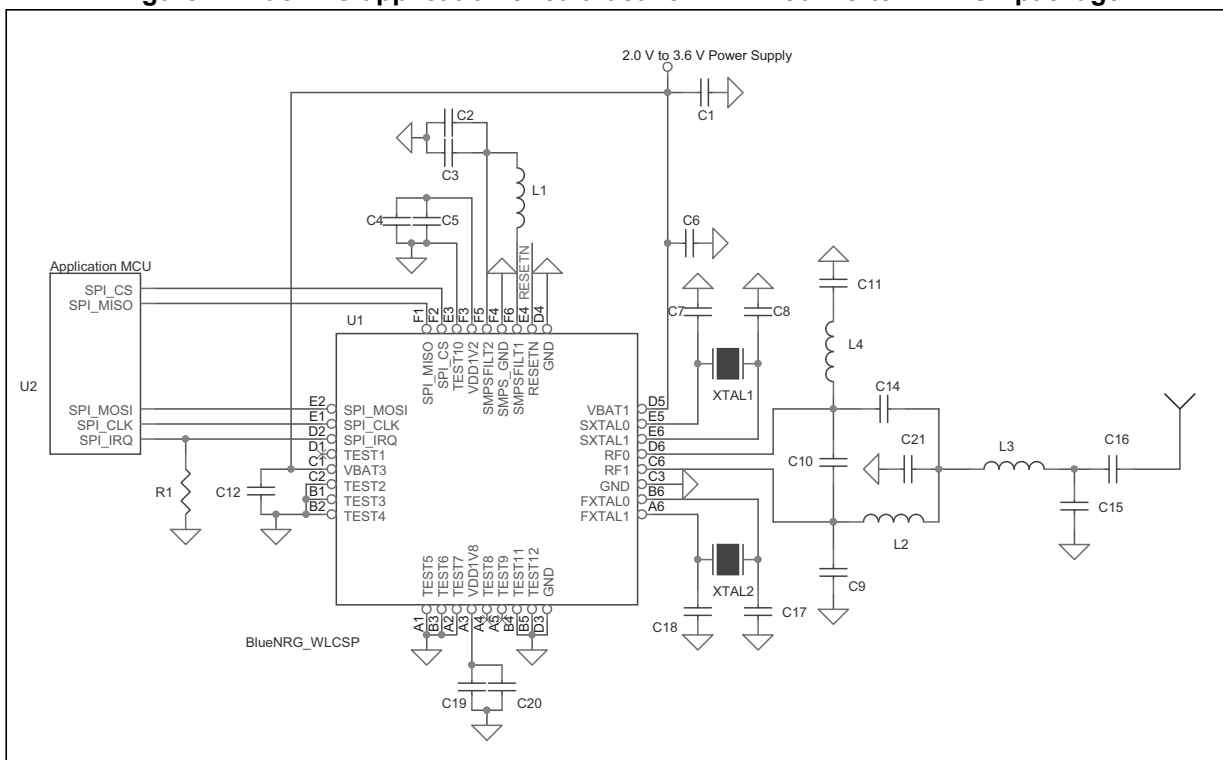

Figure 8. BlueNRG application circuit: non active DC-DC converter WLCSP package

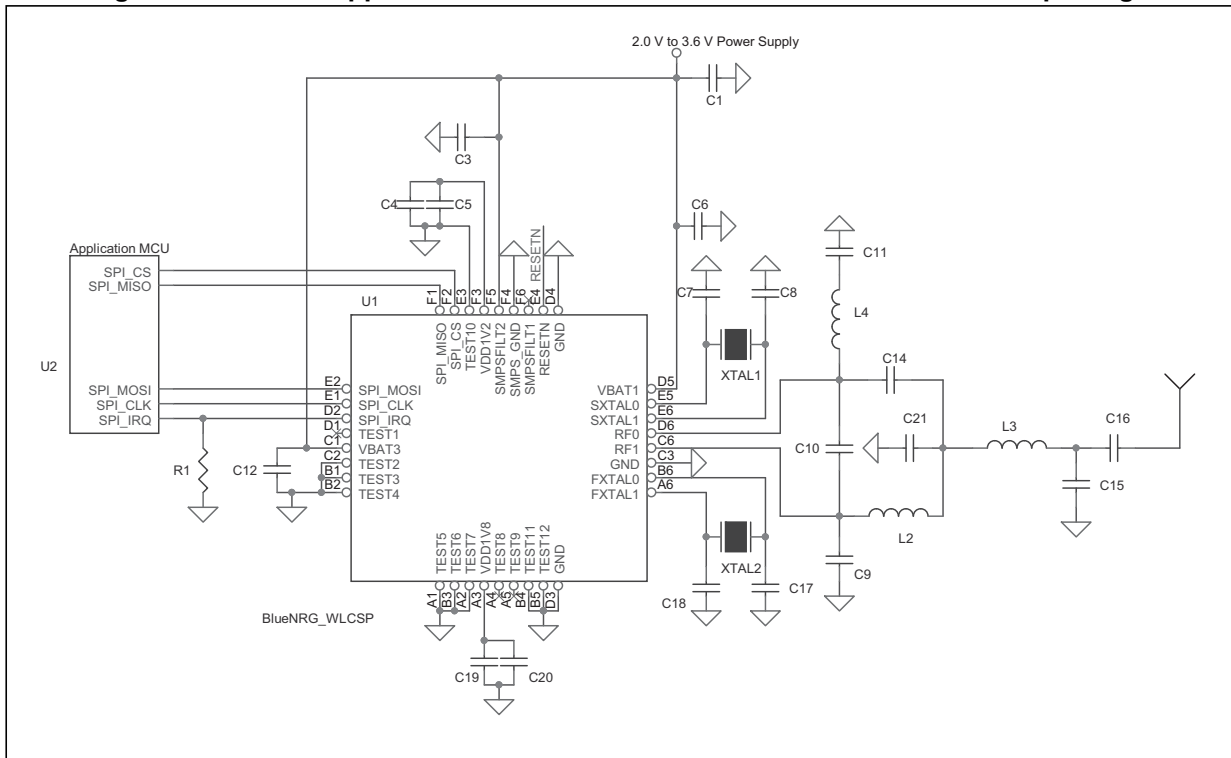

Table 3. External component list

Component	Description
C1	Decoupling capacitor
C2	DC-DC converter output capacitor
C3	DC-DC converter output capacitor
C4	Decoupling capacitor for 1.2 V digital regulator
C5	Decoupling capacitor for 1.2 V digital regulator
C6	Decoupling capacitor
C7	32 kHz crystal loading capacitor <sup>(1)</sup>
C8	32 kHz crystal loading capacitor <sup>(1)</sup>
C9	RF balun/matching network capacitor High Performance RF balun/matching network capacitor Standard mode
C10	RF balun/matching network capacitor High Performance RF balun/matching network capacitor Standard mode
C11	RF balun/matching network capacitor High Performance RF balun/matching network capacitor Standard mode
C12	Decoupling capacitor
C13	Decoupling capacitor

Table 3. External component list (continued)

Component	Description
C14	RF balun/matching network capacitor High Performance RF balun/matching network capacitor Standard mode
C15	RF balun/matching network capacitor High Performance RF balun/matching network capacitor Standard mode
C16	RF balun/matching network capacitor High Performance RF balun/matching network capacitor Standard mode
C17	16/32 MHz crystal loading capacitor
C18	16/32 MHz crystal loading capacitor
C19	Decoupling capacitor for 1.8 V digital regulator
C20	Decoupling capacitor for 1.8 V digital regulator
C21	RF balun/matching network capacitor High Performance, RF balun/matching network capacitor Standard mode
L1	DC-DC converter input inductor, Isat > 100 mA, Q > 25
L2	RF balun/matching network inductor High Performance RF balun/matching network inductor Standard mode
L3	RF balun/matching network inductor High Performance RF balun/matching network inductor Standard mode
L4	RF balun/matching network inductor High Performance RF balun/matching network inductor Standard mode
R1	Pull-down resistor on the SPI_IRQ line (can be replaced by the internal pull-down of the Application MCU)
XTAL1	32 kHz crystal (optional)
XTAL2	16/32 MHz crystal

1. Values valid only for the crystal NDK NX3215SA-32.768 kHz-EXS00A-MU00003. For other crystals refer to what specified in their datasheet.

## 5 Absolute maximum ratings and thermal data

**Table 4. Absolute maximum ratings**

Pin	Parameter	Value	Unit
5, 19, 24, 26, 28	DC-DC converter supply voltage input and output	-0.3 to +3.9	V
12, 29	DC voltage on linear voltage regulator	-0.3 to +3.9	V
1, 2, 3, 4, 6, 7, 8, 9, 10, 11, 25, 27, 30, 31, 32	DC voltage on digital input/output pins	-0.3 to +3.9	V
13, 14, 15, 16	DC voltage on analog pins	-0.3 to +3.9	V
17, 18, 22, 23	DC voltage on XTAL pins	-0.3 to +1.4	V
20, 21 <sup>(1)</sup>	DC voltage on RF pins	-0.3 to +1.4	V
T <sub>STG</sub>	Storage temperature range	-40 to +125	°C
V <sub>ESD-HBM</sub>	Electrostatic discharge voltage	±2.0	kV

1. +8 dBm input power at antenna connector in Standard mode, +11 dBm in High Power mode, with given reference design.

*Note: Absolute maximum ratings are those values above which damage to the device may occur. Functional operation under these conditions is not implied. All voltages are referred to GND.*

**Table 5. Thermal data**

Symbol	Parameter	Value	Unit
R <sub>thj-amb</sub>	Thermal resistance junction-ambient	34 (QFN32) 50 (WLCSP36)	°C/W
R <sub>thj-c</sub>	Thermal resistance junction-case	2.5 (QFN32) 25 (WLCSP36)	°C/W



## 6 General characteristics

**Table 6. Recommended operating conditions**

Symbol	Parameter	Min.	Typ.	Max.	Unit
V <sub>BAT</sub>	Operating Battery supply voltage	2.0		3.6	V
T <sub>A</sub>	Operating Ambient temperature range	-40		+85	°C

# 7 Electrical specification

## 7.1 Electrical characteristics

Characteristics measured over recommended operating conditions unless otherwise specified. Typical value are referred to  $T_A = 25\text{ }^\circ\text{C}$ ,  $V_{BAT} = 3.0\text{ V}$ . All performance data are referred to a  $50\ \Omega$  antenna connector, via reference design, QFN32 package version.

**Table 7. Electrical characteristics**

Symbol	Parameter	Test conditions	Min.	Typ.	Max.	Unit	
<b>Power consumption when DC-DC converter active</b>							
$I_{BAT}$	Supply current	Reset		5		nA	
		Standby (RAM2 OFF)		1.3		$\mu\text{A}$	
		Standby (RAM2 ON)		2		$\mu\text{A}$	
		Sleep					
		32kHz XO ON (RAM2 OFF)			1.7		$\mu\text{A}$
		32kHz XO ON (RAM2 ON)			2.4		$\mu\text{A}$
		32kHz RO ON (RAM2 OFF)			2.8		$\mu\text{A}$
		32kHz RO ON (RAM2 ON)			3.5		$\mu\text{A}$
		Active					
		CPU, flash and RAM off			2		mA
		CPU, flash and RAM on			3.3		mA
		RX High Power mode			7.7		mA
		RX Standard mode			7.3		mA
		TX Standard mode					
		+5dBm			11		mA
		0dBm			8.2		
		-2dBm			7.2		
		-6dBm			6.7		
		-9dBm			6.3		
		-12dBm			6.1		
-15dBm			5.9				
-18dBm			5.8				
TX High Power mode							
+8dBm			15.1				
+4dBm			10.9				
+2dBm			9				
-2dBm			8.3				
-5dBm			7.7				
-8dBm			7.1				
-11dBm			6.8				
-14dBm			6.6				
<b>Power consumption when DC-DC converter not active</b>							

Table 7. Electrical characteristics (continued)

Symbol	Parameter	Test conditions	Min.	Typ.	Max.	Unit	
I <sub>BAT</sub>	Supply current	Reset		5		nA	
		Standby (RAM2 OFF)		1.4		μA	
		Standby (RAM2 ON)		2			
		Sleep					
		32kHz XO ON (RAM2 OFF)			1.7		
		32kHz XO ON (RAM2 ON)			2.4		μA
		32kHz RO ON (RAM2 OFF)			2.8		
		32kHz RO ON (RAM2 ON)			3.5		
		Active					
		CPU, flash and RAM off			2.3		mA
		RX High Power mode			14.5		
		RX Standard mode			14.3		mA
		TX Standard mode					
		+5dBm			21		
		0dBm			15.4		
		-2dBm			13.3		
		-6dBm			12.2		
-9dBm			11.5				
-12dBm			11				
-15dBm			10.6				
-18dBm			10.4				
TX High Power mode							
+8dBm			28.8				
+4dBm			20.5				
+2dBm			17.2				
-2dBm			15.3				
-5dBm			14				
-8dBm			13				
-11dBm			12.3				
-14dBm			12		mA		
<b>Digital SPI input and output (SPI_MISO, SPI_MOSI, SPI_CLK, SPI_IRQ and RESET)</b>							
C <sub>IN</sub>	Port I/O capacitance		1.29	1.38	1.67	pF	
T <sub>RISE</sub>	Rise time	0.1*VDD to 0.9*VDD, CL=50pF	5		19	ns	
T <sub>FALL</sub>	Fall time	0.9*VDD to 0.1*VDD, CL=50pF	6		22	ns	
V <sub>IH</sub>	Logic high level input voltage		0.65 VDD				
V <sub>IL</sub>	Logic low level input voltage				0.35 VDD		
V <sub>OH</sub>	High level output voltage (ULPI port)	VDD = 3.3 V	2.4			V	
V <sub>OL</sub>	Low level output voltage (ULPI port)	VDD = 3.3 V			0.4	V	
<b>Digital SPI input SPI_CS</b>							

Table 7. Electrical characteristics (continued)

Symbol	Parameter	Test conditions	Min.	Typ.	Max.	Unit
C <sub>IN</sub>	Port I/O capacitance		1.29	1.38	1.67	pF
C <sub>IN</sub>	Port I/O capacitance		1.29	1.38	1.67	pF
T <sub>RISE</sub>	Rise time	0.1*VDD to 0.9*VDD, CL=50pF	5.05		18.5	ns
T <sub>FALL</sub>	Fall time	0.9*VDD to 0.1*VDD, CL=50pF	5.647		21.93	ns
V <sub>IH</sub>	Logic high level input voltage		0.65 VDD			
V <sub>IL</sub>	Logic low level input voltage				0.35 VDD	

## 7.2 RF general characteristics

Characteristics measured over recommended operating conditions unless otherwise specified. Typical value are referred to T<sub>A</sub> = 25 °C, V<sub>BAT</sub> = 3.0 V. All performance data are referred to a 50 Ω antenna connector, via reference design, QFN32 package version.

Table 8. RF general characteristics

Symbol	Parameter	Test conditions	Min.	Typ.	Max.	Unit
FREQ	Frequency range		2400		2483.5	MHz
F <sub>CH</sub>	Channel spacing			2		MHz
RF <sub>ch</sub>	RF channel center frequency		2402		2480	MHz

### 7.3 RF transmitter characteristics

Characteristics measured over recommended operating conditions unless otherwise specified. Typical value are referred to  $T_A = 25\text{ }^\circ\text{C}$ ,  $V_{BAT} = 3.0\text{ V}$ . All performance data are referred to a  $50\ \Omega$  antenna connector, via reference design, QFN32 package version.

**Table 9. RF Transmitter characteristics**

Symbol	Parameter	Test conditions	Min.	Typ.	Max.	Unit
MOD	Modulation scheme		GFSK			
BT	Bandwidth-bit period product			0.5		
$M_{index}$	Modulation index		0.45	0.5	0.55	
DR	Air data rate			1		Mbps
$ST_{acc}$	Symbol time accuracy				50	ppm
$P_{MAX}$	Maximum Output Power High Power Standard mode	At antenna connector		+8 +5	+10 +7	dBm
$P_{RFC}$	Minimum Output Power High Power Standard mode			-15 -18		dB
$P_{RFC}$	RF power accuracy				$\pm 2$	dB
$P_{BW1M}$	6 dB Bandwidth for modulated carrier (1 Mbps)	Using resolution bandwidth of 100kHz	500			kHz
$P_{RF1}$	1 <sup>st</sup> Adjacent channel transmit power 2 MHz	Using resolution bandwidth of 100 kHz and average detector			-20	dBm
$P_{RF2}$	2 <sup>nd</sup> Adjacent channel transmit Power >3MHz	Using resolution bandwidth of 100 kHz and average detector			-30	dBm
$P_{SPUR}$	Spurious emission	Harmonics included. Using resolution bandwidth of 1 MHz and average detector			-41	dBm
$CF_{dev}$	Center frequency deviation	During the packet and including both initial frequency offset and drift			$\pm 150$	kHz
$Freq_{drift}$	Frequency drift	During the packet			$\pm 50$	kHz
$IFreq_{drift}$	Initial carrier frequency drift				$\pm 20$	kHz
$DriftRate_{max}$	Maximum drift rate				400	Hz/ $\mu$ s
$Z_{LOAD}$	Optimum differential load	Standard mode @ 2440 MHz High Power mode @ 2440 MHz		25.9 + j44.4 25.4 + j20.8		$\Omega$

### 7.4 RF receiver characteristics

Characteristics measured over recommended operating conditions unless otherwise specified. Typical value are referred to  $T_A = 25\text{ }^\circ\text{C}$ ,  $V_{BAT} = 3.0\text{ V}$ . All performance data are referred to a  $50\text{ }\Omega$  antenna connector, via reference design, QFN32 package version.

**Table 10. RF receiver characteristics**

Symbol	Parameter	Test conditions	Min.	Typ.	Max.	Unit
RX <sub>SENS</sub>	Sensitivity	BER <0.1%		-88		dBm
P <sub>SAT</sub>	Saturation					
	Standard mode	BER <0.1%	-	8		dBm
	High power mode			11		
Z <sub>IN</sub>	Input differential impedance	Standard mode @ 2440 MHz High power mode @ 2440 MHz		31.4 - j26.6 28.8 - j18.5		$\Omega$
RF selectivity with BLE equal modulation on interfering signal						
C/I <sub>CO-channel</sub>	Co-channel interference	Wanted signal=-67dBm, BER≤0.1%		9		dBc
C/I <sub>1 MHz</sub>	Adjacent (+1 MHz) Interference	Wanted signal=-67dBm, BER≤0.1%		2		dBc
C/I <sub>2 MHz</sub>	Adjacent (+2 MHz) Interference	Wanted signal=-67dBm, BER≤0.1%		-34		dBc
C/I <sub>3 MHz</sub>	Adjacent (+3 MHz) Interference	Wanted signal=-67dBm, BER≤0.1%		-40		dBc
C/I <sub>≥4 MHz</sub>	Adjacent (≥±4 MHz) Interference	Wanted signal=-67dBm, BER≤0.1%		-34		dBc
C/I <sub>≥6 MHz</sub>	Adjacent (≥±6 MHz) Interference	Wanted signal=-67dBm BER≤0.1%		-45		dBc
C/I <sub>≥25 MHz</sub>	Adjacent (≥±25 MHz) Interference	Wanted signal=-67dBm, BER≤0.1%		-64		dBc
C/I <sub>Image</sub>	Image frequency Interference -2MHz	Wanted signal=-67dBm, BER≤0.1%		-20		dBc
C/I <sub>Image±1 MHz</sub>	Adjacent (±1 MHz) Interference to in-band image frequency -1MHz -3MHz	Wanted signal=-67dBm, BER≤0.1%		5 -25		dBc
Out of Band Blocking (Interfering signal CW)						
C/I <sub>Block</sub>	Interfering signal frequency 30 MHz – 2000 MHz	Wanted signal=-67dBm, BER≤0.1%, Measurement resolution 10 MHz			-30	dBm
C/I <sub>Block</sub>	Interfering signal frequency 2003 MHz – 2399 MHz	Wanted signal=-67dBm, BER≤0.1%, Measurement resolution 3 MHz			-35	dBm



Table 10. RF receiver characteristics (continued)

Symbol	Parameter	Test conditions	Min.	Typ.	Max.	Unit
C/I <sub>Block</sub>	Interfering signal frequency 2484 MHz – 2997 MHz	Wanted signal=-67 dBm, BER≤0.1%, measurement resolution 3 MHz			-35	dBm
C/I <sub>Block</sub>	Interfering signal frequency 3000 MHz – 12.75 GHz	Wanted signal=-67dBm, BER≤0.1%, measurement resolution 25 MHz	-		-30	dBm
Intermodulation characteristics (CW signal at f <sub>1</sub> , BLE interfering signal at f <sub>2</sub> )						
P_IM(3)	Input power of IM interferes at 3 and 6 MHz distance from wanted signal	Wanted signal=-64dBm, BER≤0.1%		-33		dBm
P_IM(-3)	Input power of IM interferes at -3 and -6 MHz distance from wanted signal	Wanted signal=-64dBm, BER≤0.1%		-43		dBm
P_IM(4)	Input power of IM interferes at ±4 and ±8 MHz distance from wanted signal	Wanted signal=-64dBm, BER≤0.1%	-	-33		dBm
P_IM(5)	Input power of IM interferes at ±5 and ±10 MHz distance from wanted signal	Wanted signal=-64dBm, BER≤0.1%		-33		dBm

## 7.5 High speed crystal oscillator (HSXOSC) characteristics

Characteristics measured over recommended operating conditions unless otherwise specified. Typical value are referred to T<sub>A</sub> = 25 °C, V<sub>BAT</sub> = 3.0 V.

Table 11. High speed crystal oscillator characteristics

Symbol	Parameter	Test conditions	Min.	Typ.	Max.	Unit
f <sub>NOM</sub>	Nominal frequency			16/32		MHz
f <sub>TOL</sub>	Frequency tolerance	Includes initial accuracy, stability over temperature, aging and frequency pulling due to incorrect load capacitance.			±50	ppm
ESR	Equivalent series resistance				100	Ω
P <sub>D</sub>	Drive level				100	μW

### 7.5.1 High speed crystal oscillator (HSXOSC)

The BlueNRG includes a fully integrated, low power 16/32 MHz Xtal oscillator with an embedded amplitude regulation loop. In order to achieve low power operation and good frequency stability of the Xtal oscillator, certain considerations with respect to the quartz load capacitance C<sub>0</sub> need to be taken into account. [Figure 9](#) shows a simplified block diagram of the amplitude regulated oscillator used on the BlueNRG.

Figure 9. Simplified block diagram of the amplitude regulated oscillator

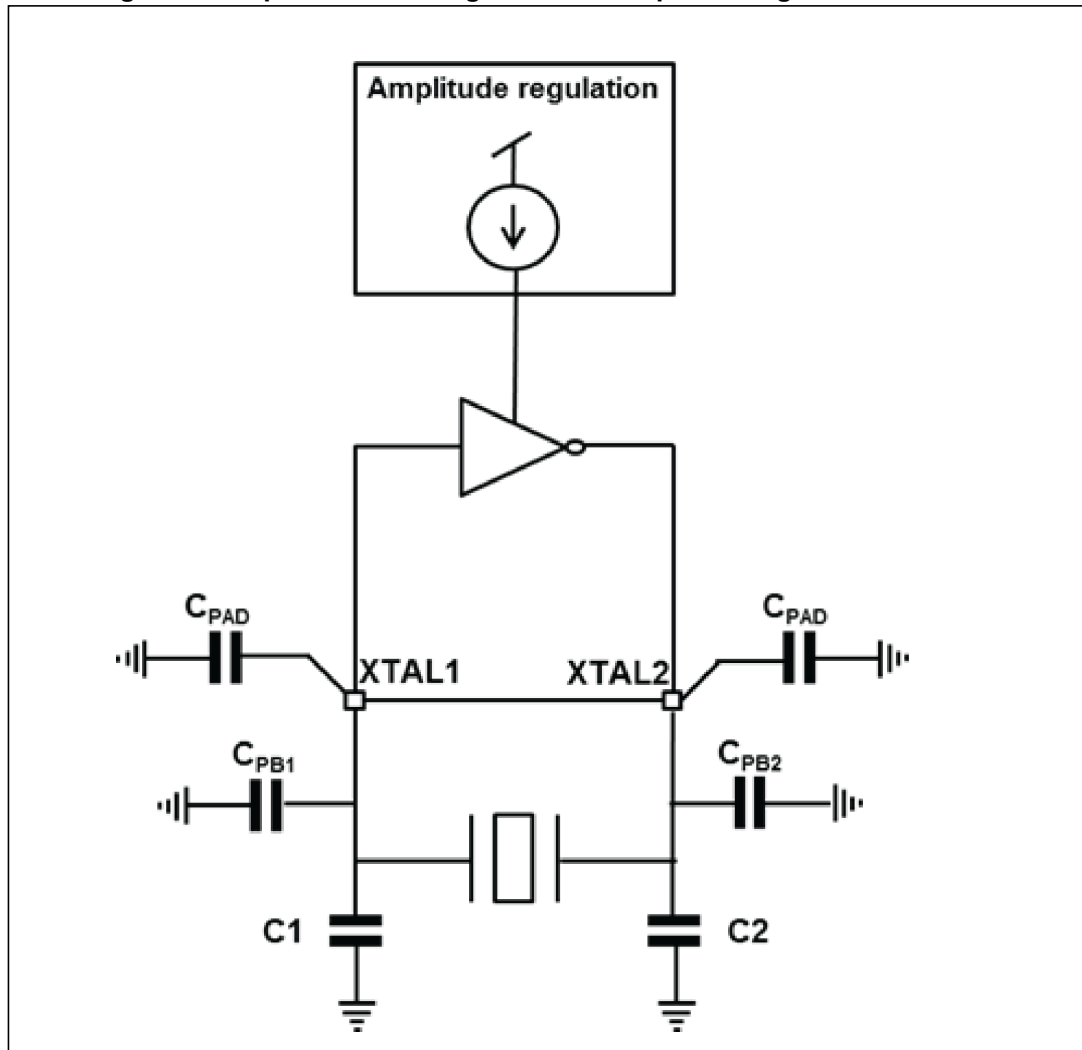

Low power consumption and fast startup time is achieved by choosing a quartz crystal with a low load capacitance  $C_0$ . A reasonable choice for capacitor  $C_0$  is 12 pF. To achieve good frequency stability, the following equation needs to be satisfied:

**Equation 1**

$$C_0 = \frac{C_1' * C_2'}{C_1' + C_2'}$$

Where  $C_1' = C_1 + C_{PCB1} + C_{PAD}$ ,  $C_2' = C_2 + C_{PCB2} + C_{PAD}$ , where  $C_1$  and  $C_2$  are external (SMD) components,  $C_{PCB1}$  and  $C_{PCB2}$  are PCB routing parasites and  $C_{PAD}$  is the equivalent small-signal pad-capacitance. The value of  $C_{PAD}$  is around 0.5 pF for each pad. The routing parasites should be minimized by placing quartz and  $C_1/C_2$  capacitors close to the chip, not only for an easier matching of the load capacitance  $C_0$ , but also to ensure robustness against noise injection. Connect each capacitor of the Xtal oscillator to ground by a separate via.



## 7.6 Low speed crystal oscillator (LSXOSC) characteristics

Characteristics measured over recommended operating conditions unless otherwise specified. Typical value are referred to  $T_A = 25\text{ }^\circ\text{C}$ ,  $V_{BAT} = 3.0\text{ V}$ .

**Table 12. Low speed crystal oscillator characteristics**

Symbol	Parameter	Test conditions	Min.	Typ.	Max.	Unit
$f_{NOM}$	Nominal frequency			32.768		kHz
$f_{TOL}$	Frequency tolerance	Includes initial accuracy, stability over temperature, aging and frequency pulling due to incorrect load capacitance.			±50	ppm
ESR	Equivalent series resistance				90	kΩ
$P_D$	Drive level				0.1	μW

Note: This values are the correct ones for NX3215SA-32.768 kHz-EXS00A-MU00003.

## 7.7 High speed ring oscillator (HSROSC) characteristics

Characteristics measured over recommended operating conditions unless otherwise specified. Typical value are referred to  $T_A = 25\text{ }^\circ\text{C}$ ,  $V_{BAT} = 3.0\text{ V}$ , QFN32 package version.

**Table 13. High speed ring oscillator characteristics**

Symbol	Parameter	Test conditions	Min.	Typ.	Max.	Unit
$f_{NOM}$	Nominal Frequency			12	16	MHz

## 7.8 Low speed ring oscillator (LSROSC) characteristics

Characteristics measured over recommended operating conditions unless otherwise specified. Typical value are referred to  $T_A = 25\text{ }^\circ\text{C}$ ,  $V_{BAT} = 3.0\text{ V}$ , QFN32 package version.

**Table 14. Low speed ring oscillator characteristics**

Symbol	Parameter	Test conditions	Min.	Typ.	Max.	Unit
32 kHz ring oscillator (LSROSC)						
$f_{NOM}$	Nominal frequency			37.4		kHz
$f_{TOL}$	Frequency tolerance				±500	ppm

## 7.9 N-fractional frequency synthesizer characteristics

Characteristics measured over recommended operating conditions unless otherwise specified. Typical value are referred to  $T_A = 25\text{ }^\circ\text{C}$ ,  $V_{BAT} = 3.0\text{ V}$ ,  $f_C = 2440\text{ MHz}$ .

**Table 15. N-fractional frequency synthesizer characteristics**

Symbol	Parameter	Test conditions	Min.	Typ.	Max.	Unit
PN <sub>SYNTH</sub>	RF carrier phase noise	At ±1MHz offset from carrier		-113		dBc/Hz
		At ±3MHz offset from carrier		-119		dBc/Hz
		At ±6MHz offset from carrier		TBD		dBc/Hz
		At ±25MHz offset from carrier		TBD		dBc/Hz
LOCK <sub>TIME</sub>	PLL lock time			40	µs	
TO <sub>TIME</sub>	PLL turn on / hop time	Including calibration			150	µs

### 7.10 Auxiliary blocks characteristics

Characteristics measured over recommended operating conditions unless otherwise specified. Typical value are referred to T<sub>A</sub> = 25 °C, V<sub>BAT</sub> =3.0 V, f<sub>c</sub> = 2440 MHz. QFN32 package version.

**Table 16. Auxiliary blocks characteristics**

Symbol	Parameter	Test conditions	Min.	Typ.	Max.	Unit
<b>Analog temperature sensor</b>						
T <sub>FERR</sub>	Error in temperature	(after calibration)	-4	0	+4	°C
T <sub>SLOPE</sub>	Temperature coefficient			3.1		mV/°C
T <sub>ICC</sub>	Current consumption			10		µA
T <sub>TS-OUT</sub>	Output voltage level			1		V
<b>Battery indicator and brown-out reset (BOR)</b>						
V <sub>BLT1</sub>	Battery level thresholds 1			2.7		V
V <sub>BLT2</sub>	Battery level thresholds 2			2.5		V
V <sub>BLT3</sub>	Battery level thresholds 3			2.3		V
V <sub>BLT4</sub>	Battery level thresholds 4			2.1		V
A <sub>BLT</sub>	Battery level thresholds accuracy				5	%
V <sub>ABOR</sub>	Ascending brown-out threshold			1.79		V
V <sub>DBOR</sub>	Descending brown-out threshold			1.73		V

## 8 Block diagram and descriptions

A block diagram of the BlueNRG is shown in *Figure 10*. In the following subsections a short description of each module is given.

**Figure 10. BlueNRG block diagram**

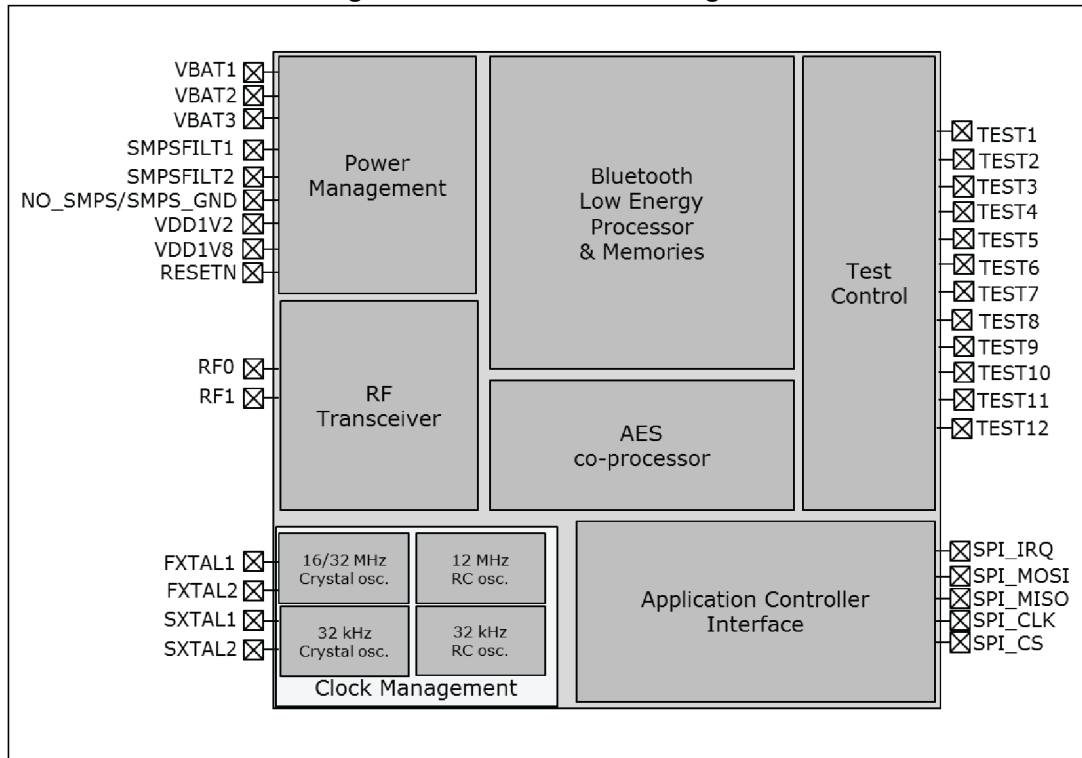

### 8.1 Core, memory and peripherals

The BlueNRG contains an ARM Cortex-M0 microcontroller core that supports ultra-low leakage state retention mode and almost instantaneously returning to fully active mode on critical events.

The memory subsystem consists of 64 KB Flash, and 12 KB RAM. Flash is used for the M0 program. No RAM or FLASH resources are available to the external microcontroller driving the BlueNRG.

The application controller interface (ACI) uses a standard SPI slave interface as transport layer, basing in five physical wires:

- 2 control wires (clock and slave select)
- 2 data wires with serial shift-out (MOSI and MISO) in full duplex
- 1 wire to indicate data availability from the slave

Table 17. SPI interface

Name	Direction	Width	Description
SPI_CS	In	1	SPI slave select = SPI enable.
SPI_CLK	In	1	SPI clock (max 8 MHz).
SPI_MOSI	In	1	Master output, slave input.
SPI_MISO	Out	1	Master input, slave output.
SPI_IRQ	Out	1	Slave has data for master.

All the SPI pins have an internal pull-down except for the CSN that has a pull-up. All the SPI pins, except the CSN, are in high impedance state during the low-power states. The IRQ pin needs a pull-down external resistor.

The BlueNRG integrates a temperature sensor to report the silicon temperature. The characteristics of the temperature sensor are defined in [Table 16](#).

The device embeds a battery level detector to monitor the supply voltage. The characteristics of the battery level detector are defined in [Table 16](#).

## 8.2 Power management

The BlueNRG integrates both a low dropout voltage regulator (LDO) and a step-down DC-DC converter, and one of them can be used to power the internal BlueNRG circuitry. However even when the LDO is used, the stringent maximum current requirements, which are advisable when coin cell batteries are used, can be met and further improvements can be obtained with the DC-DC converter at the sole additional cost of an inductor and a capacitor.

The internal LDOs supplying both the 1.8 V digital blocks and 1.2 V digital blocks require decoupling capacitors for stable operation.

[Figure 11](#) and [Figure 12](#), show the simplified power management schemes using LDO and DC-DC converter.

Figure 11. Power management strategy using LDO

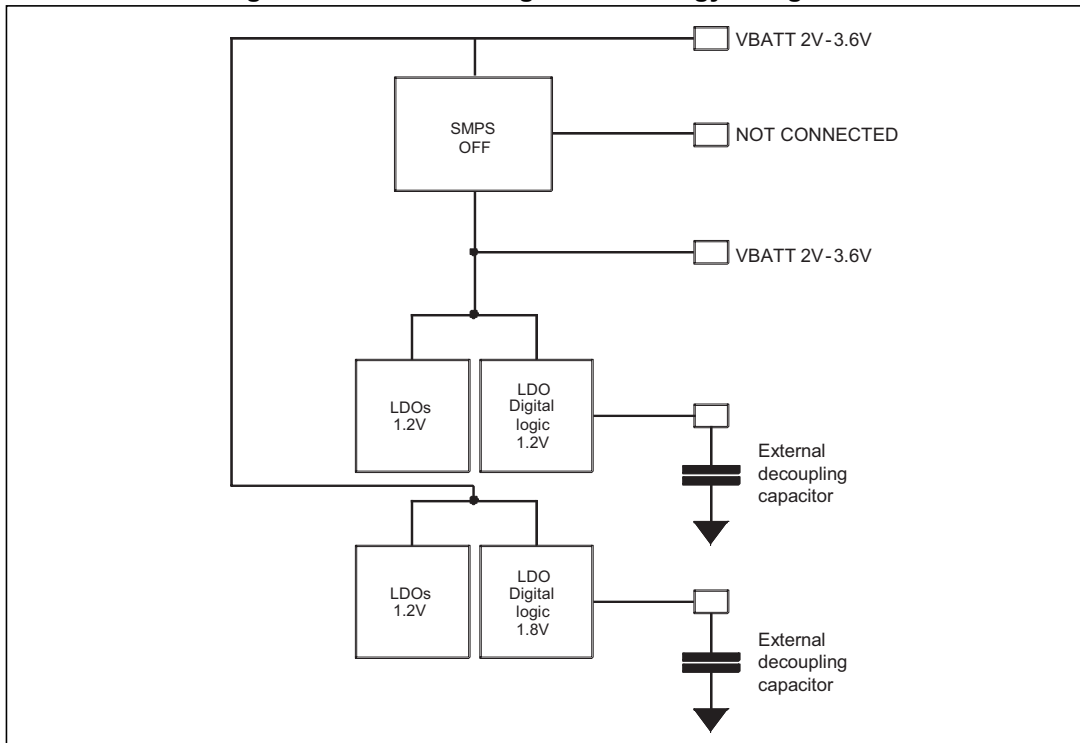
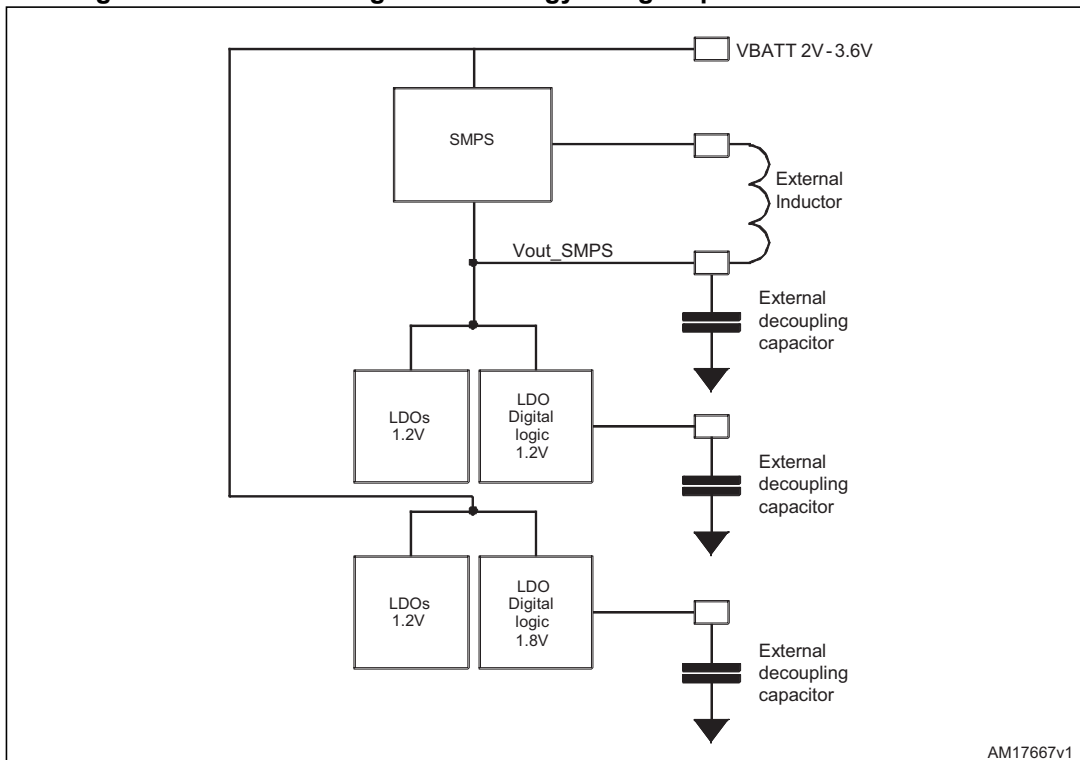

Figure 12. Power management strategy using step-down DC-DC converter



AM17667v1

### 8.3 Clock management

The BlueNRG integrates two low-speed frequency oscillators (LSOSC) and two High speed (16 MHz or 32 MHz) frequency oscillators (HSOSC).

The low frequency clock is used in Low Power mode and can be supplied either by a 32.7 kHz oscillator that uses an external crystal and guarantee up to  $\pm 50$  ppm frequency tolerance, or by a ring oscillator with maximum  $\pm 500$  ppm frequency tolerance, which does not require any external components.

The primary high frequency clock is a 16 MHz or 32 MHz crystal oscillator. There is also a fast-starting 12 MHz ring oscillator that provides the clock while the crystal oscillator is starting up. Frequency tolerance of high speed crystal oscillator is  $\pm 50$  ppm.

The usage of the 16 MHz (or 32 MHz) crystal is strictly necessary.

### 8.4 Bluetooth low energy radio

The BlueNRG integrates a RF transceiver compliant to the Bluetooth specification and to the standard national regulations in the unlicensed 2.4 GHz ISM band.

The RF transceiver requires very few external discrete components. It provides 96 dB link budgets with excellent link reliability, keeping the maximum peak current below 15 mA.

In Transmit mode, the power amplifier (PA) drives the signal generated by the frequency synthesizer out to the antenna terminal through a very simple external network. The power delivered as well as the harmonic content depends on the external impedance seen by the PA.

The output power is programmable from -18 dBm to +8 dBm, to allow a user-defined power control system and to guarantee optimum power consumption for each scenario.

## 9 Operating modes

Several operating modes are defined for the BlueNRG:

- Reset mode
- Sleep mode
- Standby mode
- Active mode
- Radio mode
  - Receive Radio mode
  - Transmit Radio mode

In Reset mode, the BlueNRG is in ultra-low power consumption: all voltage regulators, clocks and the RF interface are not powered. The BlueNRG enters Reset mode by asserting the external reset signal. As soon as it is de-asserted, the device follows the normal activation sequence to transit to Active mode.

In Sleep mode either the low speed crystal oscillator or the low speed ring oscillator are running, whereas the high speed oscillators are powered down as well as the RF interface. The state of the BlueNRG is retained and the content of the RAM is preserved.

While in Sleep mode, the BlueNRG waits until an internal timer expires and then it goes into Active mode. The transition from Sleep mode to Active mode can also be activated through the SPI interface.

Standby mode and Sleep mode are equivalent but the low speed frequency oscillators are powered down. In Standby mode the BlueNRG can be activated through the SPI interface.

In Active mode the BlueNRG is fully operational: all interfaces, including SPI and RF, are active as well as all internal power supplies together with the high speed frequency oscillator. The MCU core is also running.

Radio mode differs from Active mode as also the RF transceiver is active and it is capable of either transmitting or receiving.

*Figure 13* reports the simplified state machine:

Figure 13. Simplified state machine

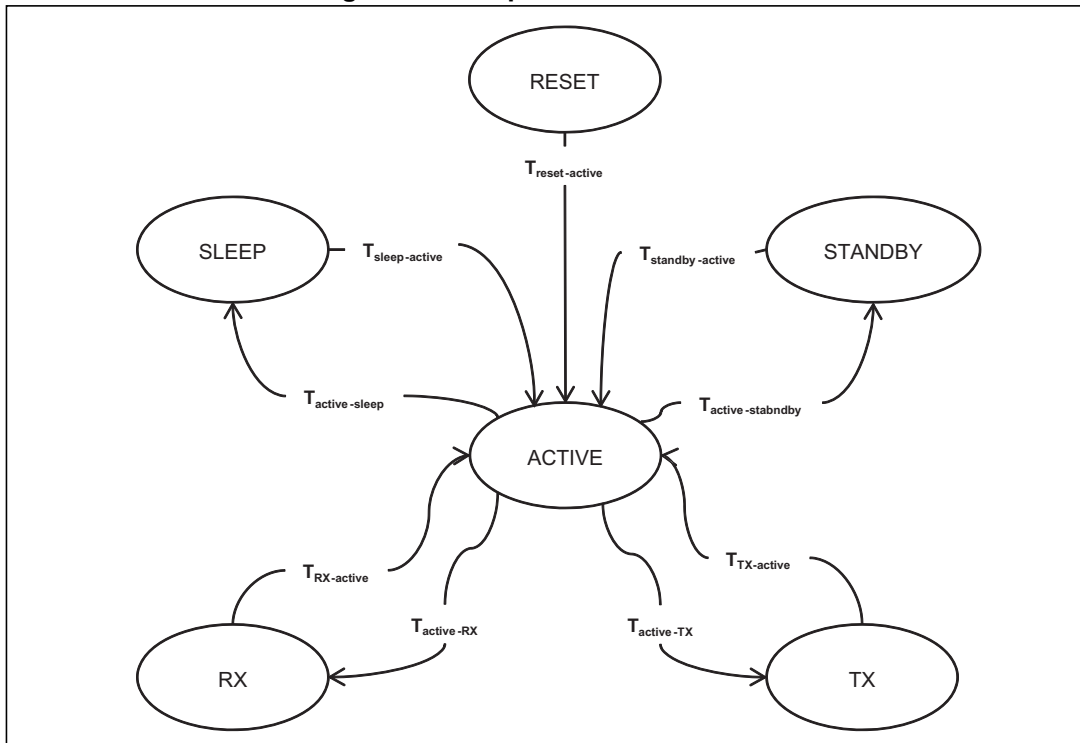

Table 18. BlueNRG operating modes

State	Digital LDO	SPI	LSOSC	HSOSC	Core	RF synt.	RX chain	TX chain
Reset	OFF Register contents lost	OFF	OFF	OFF	OFF	OFF	OFF	OFF
Standby	ON Register contents retained	ON	OFF	OFF	OFF	OFF	OFF	OFF
Sleep	ON Register contents retained	ON	ON	OFF	OFF	OFF	OFF	OFF
Active	ON Register contents retained	ON	-	ON	ON	OFF	OFF	OFF
RX	ON Register contents retained	ON	-	ON	ON	ON	ON	OFF
TX	ON Register contents retained	ON	-	ON	ON	ON	OFF	ON



Table 19. BlueNRG transition times

Transition	Maximum time	Condition
Reset-active <sup>(1)</sup>	1.5 ms	32 kHz not available
	7 ms	32 kHz RO
	94 ms	32 kHz XO
Standby-active <sup>(1)</sup>	0.42 ms	32 kHz not available
	6.2 ms	32 kHz RO
	93 ms	32 kHz XO
Sleep-active <sup>(1)</sup>	0.42 ms	
Active-RX	125 $\mu$ s	Channel change
	61 $\mu$ s	No channel change
Active-TX	131 $\mu$ s	Channel change
	67 $\mu$ s	No channel change
RX-TX or TX-RX	150 $\mu$ s	

1. These measurements are taken using NX3225SA-16.000 MHz-EXS00A-CS05997.

## 10 Application controller interface

The application controller interface is based on a standard SPI module with speeds up to 8 MHz. The application controller Interface defines a software protocol providing functions to access all the services offered by the layers of the embedded Bluetooth stack. The ACI commands are described in the BlueNRG ACI command interface document.

## 11 Package mechanical data

In order to meet environmental requirements, ST offers these devices in different grades of ECOPACK<sup>®</sup> packages, depending on their level of environmental compliance. ECOPACK<sup>®</sup> specifications, grade definitions and product status are available at: [www.st.com](http://www.st.com). ECOPACK<sup>®</sup> is an ST trademark.

Figure 14. QFN32 (5 x 5 x 1 pitch 0.5 mm) drawing

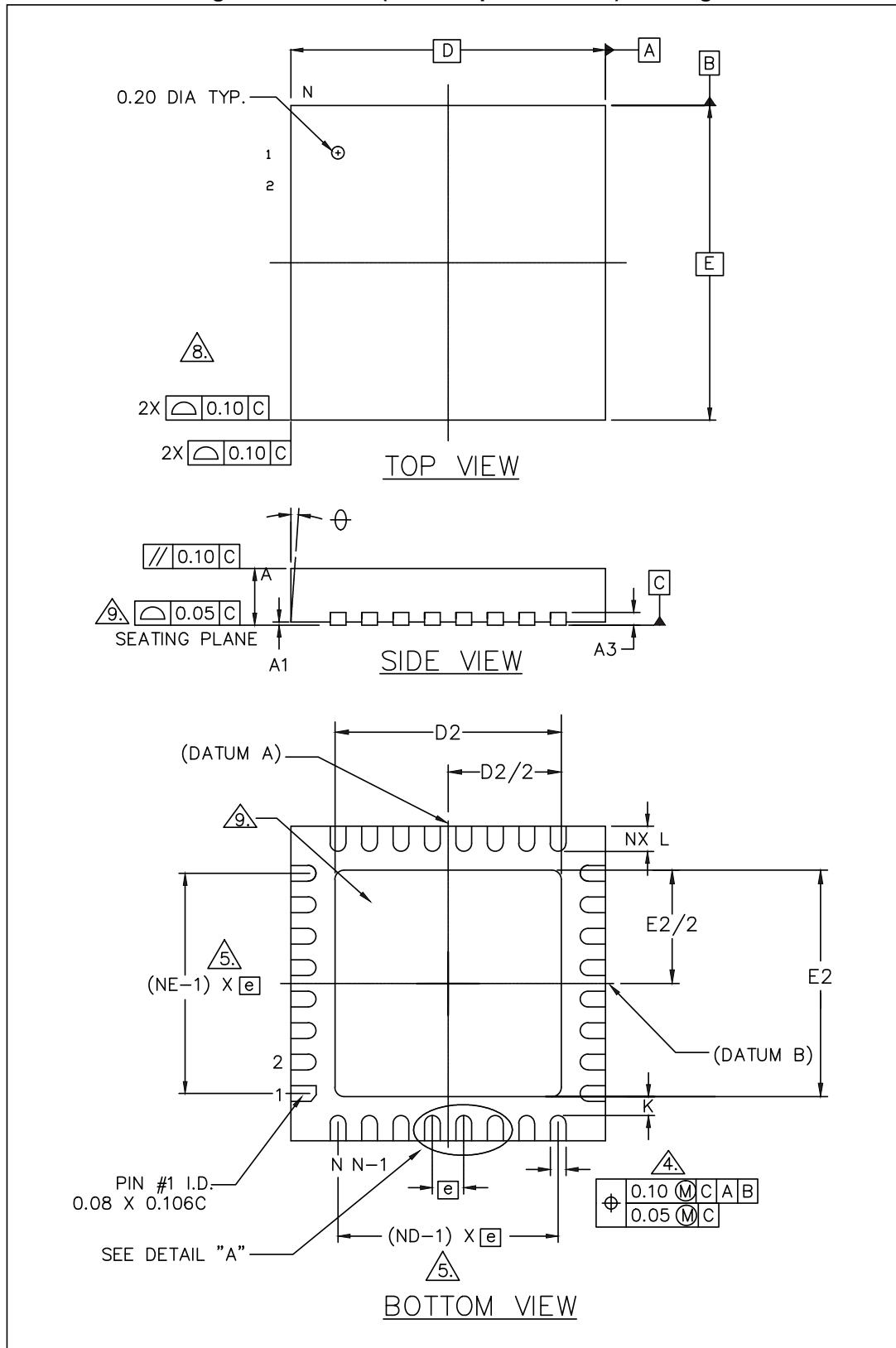
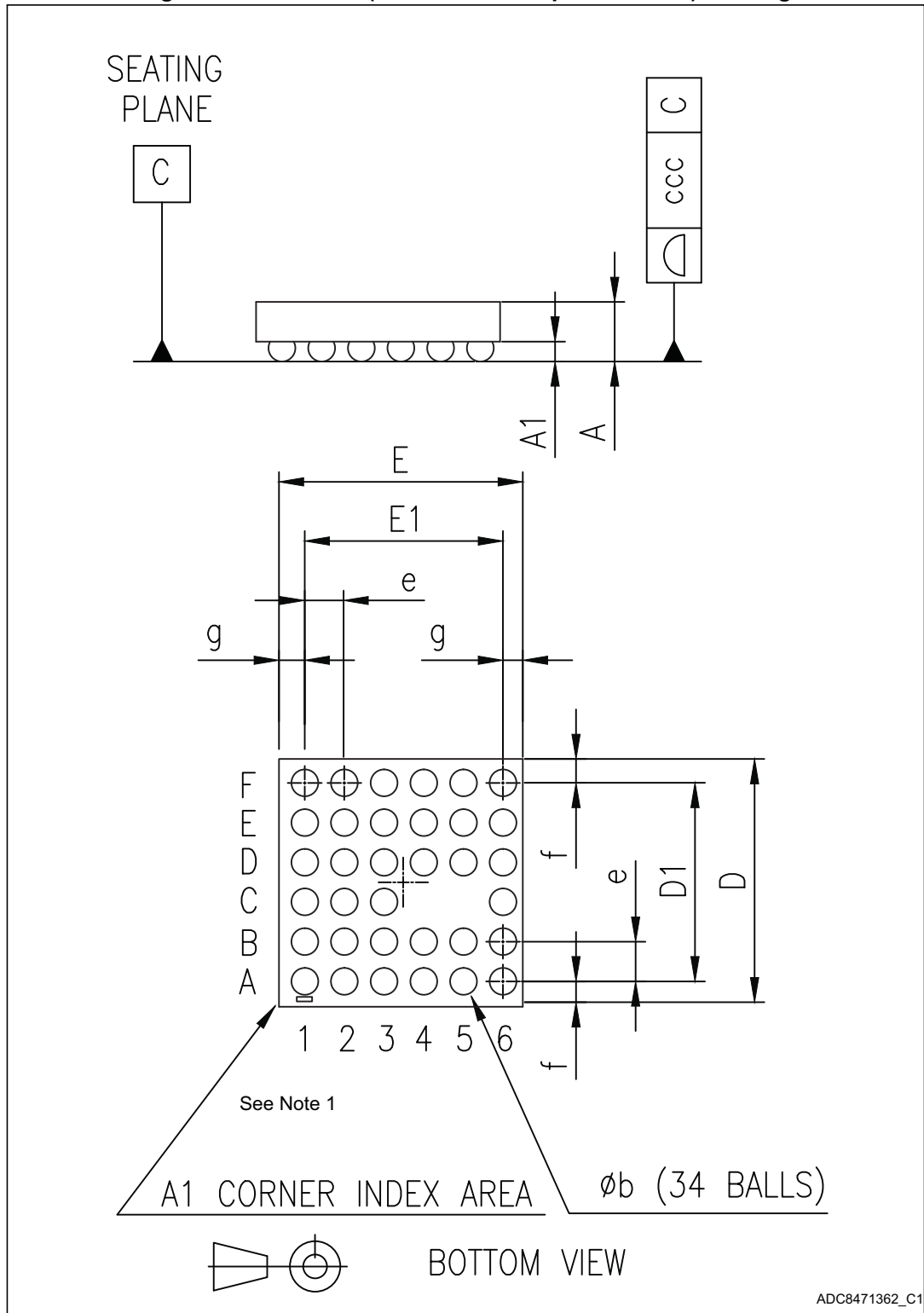

Table 20. QFN32 (5 x 5 x 1 pitch 0.5 mm) mechanical data

Dim.	mm		
	Min.	Typ.	Max.
A	0.80	0.85	1.00
A1	0	0.02	0.05
A3	0.20 REF		
b	0.25	0.25	0.30
D	5.00 BSC		
E	5.00 BSC		
D2	3.2		3.70
E2	3.2		3.70
e	0.5 BSC		
L	0.30	0.40	0.50
$\Phi$	0°		14°
K	0.20		

Figure 15. WLCSP34 (2.66 x 2.56 x 0.5 pitch 0.4 mm) drawing



ADC8471362\_C1

1. The corner of terminal A1 must be identified on the top surface by using a laser marking dot see [Figure 3](#).

Table 21. WLCSP34 (2.66 x 2.56 x 0.5 pitch 0.4 mm) mechanical data<sup>(1)</sup>

Dim.	mm.			Notes
	Min.	Typ.	Max.	
A			0.50	
A1		0.20		
b		0.27		(2)
D	2.50	2.56	2.58	(3)
D1		2.00		
E	2.60	2.66	2.68	(4)
E1		2.00		
e		0.40		
f		0.28		
g		0.33		
ccc			0.05	

1. WLCSP stands for Wafer Level Chip Scale Package.
2. The typical ball diameter before mounting is 0.25 mm.
3.  $D = f + D1 + f$ .
4.  $E = g + E1 + g$ .

## 12 PCB assembly guidelines

For Flip Chip mounting on the PCB, STMicroelectronics recommends the use of a solder stencil aperture of 330 x 330 µm maximum and a typical stencil thickness of 125 µm. Flip Chips are fully compatible with the use of near eutectic 95.8% Sn, 3.5% Ag, 0.7% Cu solder paste with no-clean flux. ST's recommendations for Flip Chip board mounting are illustrated on the soldering reflow profile shown in [Figure 16](#).

**Figure 16. Flip Chip CSP (2.66 x 2.56 x 0.5 pitch 0.4 mm) package reflow profile recommendation**

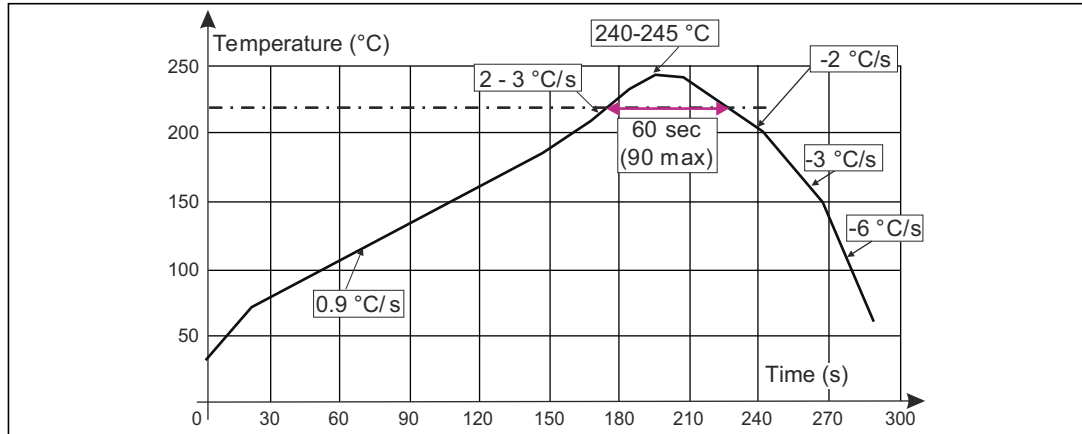

**Table 22. Flip Chip CSP (2.66 x 2.56 x 0.5 pitch 0.4 mm) package reflow profile recommendation**

Profile	Value	
	Typ.	Max.
Temp. gradient in preheat (T = 70 – 180 °C)	0.9 °C/s	3 °C/s
Temp. gradient (T = 200 – 225 °C)	2 °C/s	3 °C/s
Peak temp. in reflow	240 - 245 °C	260 °C
Time above 220 °C	60 s	90 s
Temp. gradient in cooling	-2 to -3 °C/s	-6 °C/s
Time from 50 to 220 °C	160 to 220 s	

Dwell time in the soldering zone (with temperature higher than 220 °C) has to be kept as short as possible to prevent component and substrate damage. Peak temperature must not exceed 260 °C. Controlled atmosphere (N<sub>2</sub> or N<sub>2</sub>H<sub>2</sub>) is recommended during the whole reflow, especially above 150 °C.

Flip Chips are able to withstand three times the previous recommended reflow profile to be compatible with a double reflow when SMDs are mounted on both sides of the PCB plus one additional repair.

A maximum of three soldering reflows are allowed for these lead-free packages (with repair step included).



The use of a no-clean paste is highly recommended to avoid any cleaning operation. To prevent any bump cracks, ultrasonic cleaning methods are not recommended.

## 13 Revision history

**Table 23. Document revision history**

Date	Revision	Changes
09-Aug-2013	1	Initial release.
07-Feb-2014	2	<ul style="list-style-type: none"> <li>– Datasheet promoted from preliminary data to production data</li> <li>– Added WLCSP34 package to <a href="#">Table 1: Device summary</a></li> <li>– Deleted references to “low power ADC” throughout the document.</li> <li>– Added pin information for the WLCSP package to <a href="#">Figure 3 on page 9</a>, <a href="#">Table 2: Pinout description</a></li> <li>– Updated <a href="#">Figure 5</a> and <a href="#">Figure 6 on page 13</a></li> <li>– Added <a href="#">Figure 7: BlueNRG application circuit: active DC-DC converter WLCSP package</a> and <a href="#">Figure 8: BlueNRG application circuit: non active DC-DC converter WLCSP package</a></li> <li>– Modified High Performance and Standard Mode values in <a href="#">Figure 3: External component list</a></li> <li>– Changed all references the term “Slave” to “RAM2 OFF”, and “Master” to “RAM2 ON” in <a href="#">Figure 7: Electrical characteristics</a></li> <li>– Modified title of <a href="#">Table 16</a></li> <li>– Modified <a href="#">Figure 10.: BlueNRG block diagram</a></li> <li>– Corrected error in typical BSC value for reference “e” in <a href="#">Table 20</a>.</li> <li>– Added WLCSP package drawing and dimensions data (<a href="#">Figure 15</a> and <a href="#">Table 21</a>)</li> <li>– Minor text corrections throughout the document.</li> </ul>
19-Mar-2014	3	<p>Added:</p> <ul style="list-style-type: none"> <li>– <a href="#">Figure 3 on page 9</a>.</li> </ul> <p>Updated:</p> <ul style="list-style-type: none"> <li>– <a href="#">Figure 5</a> and <a href="#">Figure 6 on page 13</a>, <a href="#">Figure 7</a> and <a href="#">Figure 8 on page 14</a>.</li> </ul>
21-Mar-2014	4	<p>Added:</p> <ul style="list-style-type: none"> <li>– <a href="#">Section 12: PCB assembly guidelines on page 40</a>.</li> </ul>
17-Nov-2014	5	<p>Updated: <a href="#">Table 2</a>, <a href="#">Table 3</a>, <a href="#">Table 5</a>, <a href="#">Table 11</a>, <a href="#">Table 12</a>, <a href="#">Table 15</a>, <a href="#">Section 7.7</a> and <a href="#">Section 8</a>,</p> <p>Added: <a href="#">Section 7.5.1</a></p>

**IMPORTANT NOTICE – PLEASE READ CAREFULLY**

STMicroelectronics NV and its subsidiaries (“ST”) reserve the right to make changes, corrections, enhancements, modifications, and improvements to ST products and/or to this document at any time without notice. Purchasers should obtain the latest relevant information on ST products before placing orders. ST products are sold pursuant to ST’s terms and conditions of sale in place at the time of order acknowledgement.

Purchasers are solely responsible for the choice, selection, and use of ST products and ST assumes no liability for application assistance or the design of Purchasers’ products.

No license, express or implied, to any intellectual property right is granted by ST herein.

Resale of ST products with provisions different from the information set forth herein shall void any warranty granted by ST for such product.

ST and the ST logo are trademarks of ST. All other product or service names are the property of their respective owners.

Information in this document supersedes and replaces information previously supplied in any prior versions of this document.

© 2014 STMicroelectronics – All rights reserved