

GENERAL PURPOSE 6-PIN PHOTOTRANSISTOR OPTOCOUPLERS

4N25
4N37

4N26
H11A1

4N27
H11A2

4N28
H11A3

4N35
H11A4

4N36
H11A5

WHITE PACKAGE (-M SUFFIX)

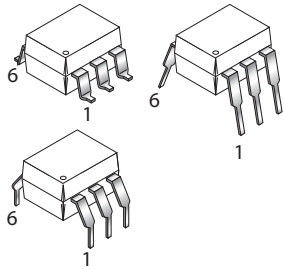

SCHEMATIC

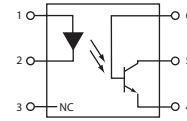

PIN 1. ANODE
2. CATHODE
3. NO CONNECTION
4. EMITTER
5. COLLECTOR
6. BASE

BLACK PACKAGE (NO -M SUFFIX)

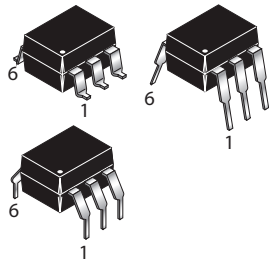

DESCRIPTION

The general purpose optocouplers consist of a gallium arsenide infrared emitting diode driving a silicon phototransistor in a 6 -pin dual in-line package.

FEATURES

- Also available in white package by specifying -M suffix, eg. 4N25-M
- UL recognized (File # E90700)
- VDE recognized (File # 94766)
 - Add option V for white package (e.g., 4N25V-M)
 - Add option 300 for black package (e.g., 4N25.300)

APPLICATIONS

- Power supply regulators
- Digital logic inputs
- Microprocessor inputs

GENERAL PURPOSE 6-PIN PHOTOTRANSISTOR OPTOCOUPLEDERS

4N25	4N26	4N27	4N28	4N35	4N36
4N37	H11A1	H11A2	H11A3	H11A4	H11A5

ABSOLUTE MAXIMUM RATINGS ($T_A = 25\text{ }^\circ\text{C}$ unless otherwise specified)			
Parameter	Symbol	Value	Units
TOTAL DEVICE			
Storage Temperature	T_{STG}	-55 to +150	$^\circ\text{C}$
Operating Temperature	T_{OPR}	-55 to +100	$^\circ\text{C}$
Lead Solder Temperature	T_{SOL}	260 for 10 sec	$^\circ\text{C}$
Total Device Power Dissipation @ $T_A = 25\text{ }^\circ\text{C}$ Derate above $25\text{ }^\circ\text{C}$	P_D	250 3.3 (non-M), 2.94 (-M)	mW
EMITTER			
DC/Average Forward Input Current	I_F	100 (non-M), 60 (-M)	mA
Reverse Input Voltage	V_R	6	V
Forward Current - Peak (300 μs , 2% Duty Cycle)	$I_F(\text{pk})$	3	A
LED Power Dissipation @ $T_A = 25\text{ }^\circ\text{C}$ Derate above $25\text{ }^\circ\text{C}$	P_D	150 (non-M), 120 (-M) 2.0 (non-M), 1.41 (-M)	mW mW/ $^\circ\text{C}$
DETECTOR			
Collector-Emitter Voltage	V_{CEO}	30	V
Collector-Base Voltage	V_{CBO}	70	V
Emitter-Collector Voltage	V_{ECO}	7	V
Detector Power Dissipation @ $T_A = 25\text{ }^\circ\text{C}$ Derate above $25\text{ }^\circ\text{C}$	P_D	150 2.0 (non-M), 1.76 (-M)	mW mW/ $^\circ\text{C}$

GENERAL PURPOSE 6-PIN PHOTOTRANSISTOR OPTOCOUPLEDERS

4N25	4N26	4N27	4N28	4N35	4N36
4N37	H11A1	H11A2	H11A3	H11A4	H11A5

ELECTRICAL CHARACTERISTICS

($T_A = 25\text{ }^\circ\text{C}$ unless otherwise specified)

INDIVIDUAL COMPONENT CHARACTERISTICS

Parameter	Test Conditions	Symbol	Min	Typ*	Max	Unit
EMITTER						
Input Forward Voltage	($I_F = 10\text{ mA}$)	V_F		1.18	1.50	V
Reverse Leakage Current	($V_R = 6.0\text{ V}$)	I_R		0.001	10	μA
DETECTOR						
Collector-Emitter Breakdown Voltage	($I_C = 1.0\text{ mA}, I_F = 0$)	BV_{CEO}	30	100		V
Collector-Base Breakdown Voltage	($I_C = 100\text{ }\mu\text{A}, I_F = 0$)	BV_{CBO}	70	120		V
Emitter-Collector Breakdown Voltage	($I_E = 100\text{ }\mu\text{A}, I_F = 0$)	BV_{ECO}	7	10		V
Collector-Emitter Dark Current	($V_{CE} = 10\text{ V}, I_F = 0$)	I_{CEO}		1	50	nA
Collector-Base Dark Current	($V_{CB} = 10\text{ V}$)	I_{CBO}			20	nA
Capacitance	($V_{CE} = 0\text{ V}, f = 1\text{ MHz}$)	C_{CE}		8		pF

ISOLATION CHARACTERISTICS

Characteristic	Test Conditions	Symbol	Min	Typ*	Max	Units
Input-Output Isolation Voltage	(Non '-M', Black Package) ($f = 60\text{ Hz}, t = 1\text{ min}$)	V_{ISO}	5300			Vac(rms)
	('-'M', White Package) ($f = 60\text{ Hz}, t = 1\text{ sec}$)		7500			Vac(pk)
Isolation Resistance	($V_{I-O} = 500\text{ VDC}$)	R_{ISO}	10^{11}			Ω
Isolation Capacitance	($V_{I-O} = \&, f = 1\text{ MHz}$)	C_{ISO}		0.5		pF
	('-'M' White Package)			0.2	2	pF

Note

* Typical values at $T_A = 25\text{ }^\circ\text{C}$

GENERAL PURPOSE 6-PIN PHOTOTRANSISTOR OPTOCOUPLEDERS

4N25
4N37

4N26
H11A1

4N27
H11A2

4N28
H11A3

4N35
H11A4

4N36
H11A5

TRANSFER CHARACTERISTICS ($T_A = 25^\circ\text{C}$ Unless otherwise specified.)								
DC Characteristic	Test Conditions	Symbol	Device	Min	Typ*	Max	Unit	
Current Transfer Ratio, Collector to Emitter	$(I_F = 10\text{ mA}, V_{CE} = 10\text{ V})$	CTR	4N35 4N36 4N37	100			%	
			H11A1	50				
			H11A5	30				
			4N25 4N26 H11A2 H11A3	20				
	4N27 4N28 H11A4		10					
	4N35 4N36 4N37		40					
$(I_F = 10\text{ mA}, V_{CE} = 10\text{ V}, T_A = -55^\circ\text{C})$								
$(I_F = 10\text{ mA}, V_{CE} = 10\text{ V}, T_A = +100^\circ\text{C})$								
Collector-Emitter Saturation Voltage	$(I_C = 2\text{ mA}, I_F = 50\text{ mA})$	$V_{CE(SAT)}$	4N25 4N26 4N27 4N28				0.5	V
	$(I_C = 0.5\text{ mA}, I_F = 10\text{ mA})$		4N35 4N36 4N37				0.3	
			H11A1 H11A2 H11A3 H11A4 H11A5				0.4	
AC Characteristic								
Non-Saturated Turn-on Time	$(I_F = 10\text{ mA}, V_{CC} = 10\text{ V}, R_L = 100\ \Omega)$ (Fig.20)	T_{ON}	4N25 4N26 4N27 4N28 H11A1 H11A2 H11A3 H11A4 H11A5			2	μs	
Non Saturated Turn-on Time	$(I_C = 2\text{ mA}, V_{CC} = 10\text{ V}, R_L = 100\ \Omega)$ (Fig.20)	T_{ON}	4N35 4N36 4N37			2	10	μs

GENERAL PURPOSE 6-PIN PHOTOTRANSISTOR OPTOCOUPLEDERS

4N25	4N26	4N27	4N28	4N35	4N36
4N37	H11A1	H11A2	H11A3	H11A4	H11A5

TRANSFER CHARACTERISTICS ($T_A = 25^\circ\text{C}$ Unless otherwise specified.) (Continued)									
AC Characteristic	Test Conditions	Symbol	Device	Min	Typ*	Max	Unit		
Turn-off Time	($I_F = 10\text{ mA}, V_{CC} = 10\text{ V}, R_L = 100\ \Omega$) (Fig.20)	T_{OFF}	4N25			2			
			4N26						
			4N27						
			4N28						
			H11A1					μs	
			H11A2						
			H11A3						
			H11A4						
			H11A5						
	($I_C = 2\text{ mA}, V_{CC} = 10\text{ V}, R_L = 100\ \Omega$) (Fig.20)		4N35			2	10		
			4N36						
			4N37						

* Typical values at $T_A = 25^\circ\text{C}$

GENERAL PURPOSE 6-PIN PHOTOTRANSISTOR OPTOCOUPLEDERS

4N25	4N26	4N27	4N28	4N35	4N36
4N37	H11A1	H11A2	H11A3	H11A4	H11A5

TRANSFER CHARACTERISTICS ($T_A = 25^\circ\text{C}$ Unless otherwise specified.) (Continued)								
AC Characteristic	Test Conditions	Symbol	Device	Min	Typ*	Max	Unit	
Turn-off Time	($I_F = 10\text{ mA}, V_{CC} = 10\text{ V}, R_L = 100\ \Omega$) (Fig.20)	T_{OFF}	4N25 4N26 4N27 4N28 H11A1 H11A2 H11A3 H11A4 H11A5			2		μs
	($I_C = 2\text{ mA}, V_{CC} = 10\text{ V}, R_L = 100\ \Omega$) (Fig.20)		4N35 4N36 4N37			2	10	

* Typical values at $T_A = 25^\circ\text{C}$

GENERAL PURPOSE 6-PIN PHOTOTRANSISTOR OPTOCOUPLEDERS

4N25
4N37

4N26
H11A1

4N27
H11A2

4N28
H11A3

4N35
H11A4

4N36
H11A5

TYPICAL PERFORMANCE CURVES

Fig. 1 LED Forward Voltage vs. Forward Current
(Black Package)

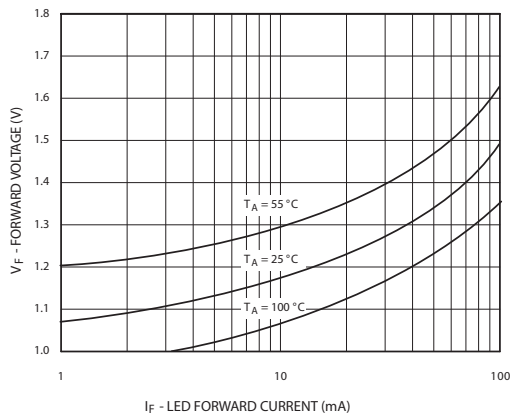

Fig. 2 LED Forward Voltage vs. Forward Current
(White Package)

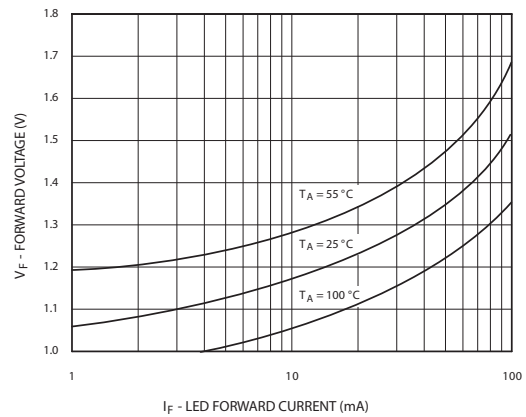

Fig. 3 Normalized CTR vs. Forward Current
(Black Package)

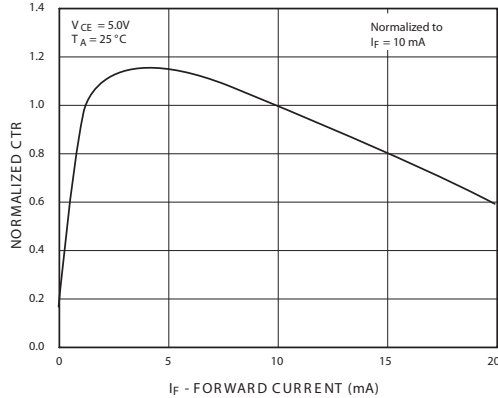

Fig. 4 Normalized CTR vs. Forward Current
(White Package)

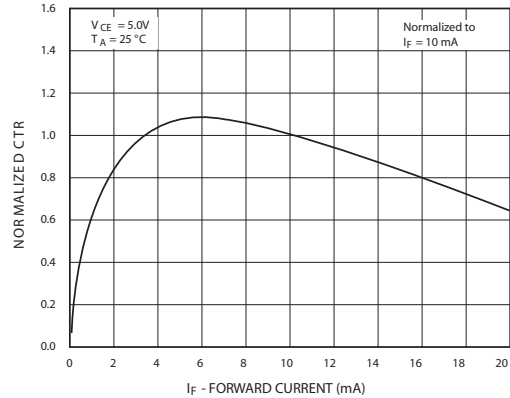

Fig. 5 Normalized CTR vs. Ambient Temperature
(Black Package)

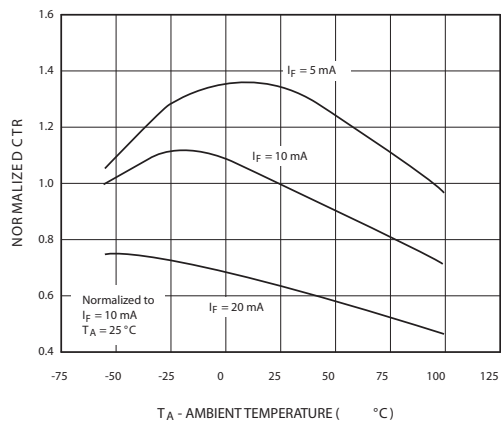
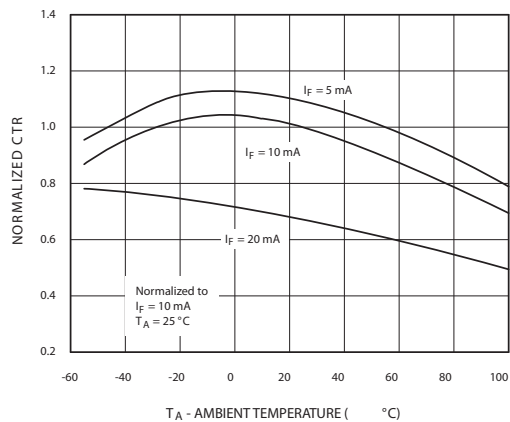

Fig. 6 Normalized CTR vs. Ambient Temperature
(White Package)



GENERAL PURPOSE 6-PIN PHOTOTRANSISTOR OPTOCOUPLEDERS

4N25
4N37

4N26
H11A1

4N27
H11A2

4N28
H11A3

4N35
H11A4

4N36
H11A5

Fig. 13 Switching Speed vs. Load Resistor
(Black Package)

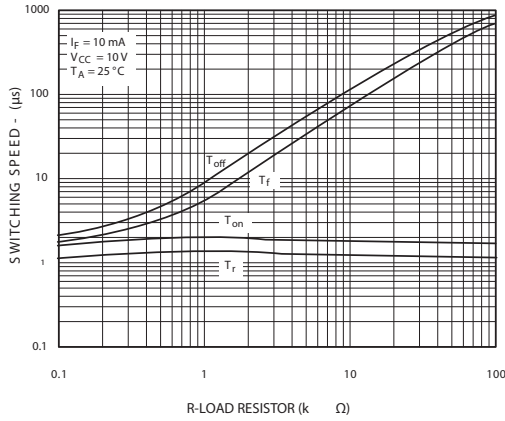

Fig. 14 Switching Speed vs. Load Resistor
(White Package)

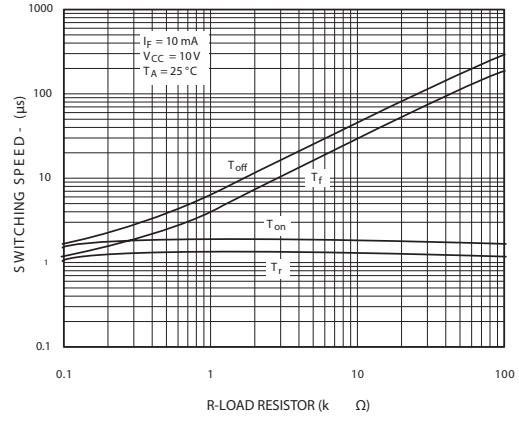

Fig. 15 Normalized t_{on} vs. R_{BE}
(Black Package)

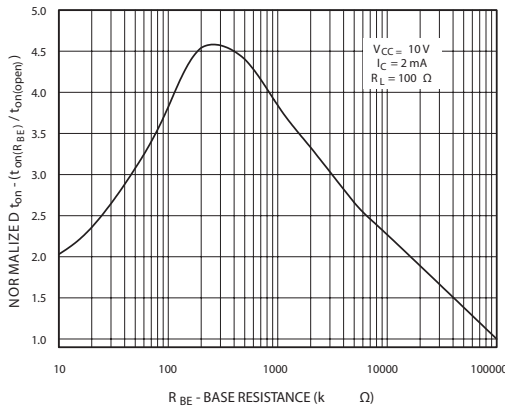

Fig. 16 Normalized t_{on} vs. R_{BE}
(White Package)

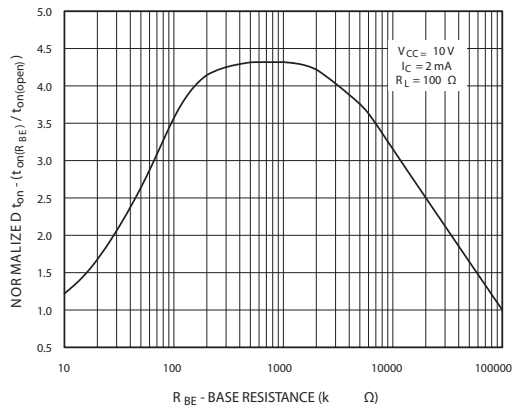

Fig. 17 Normalized t_{off} vs. R_{BE}
(Black Package)

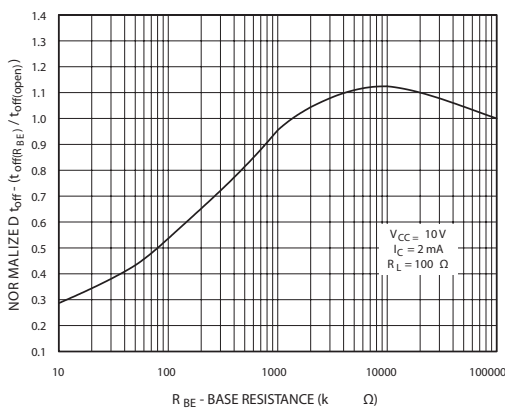
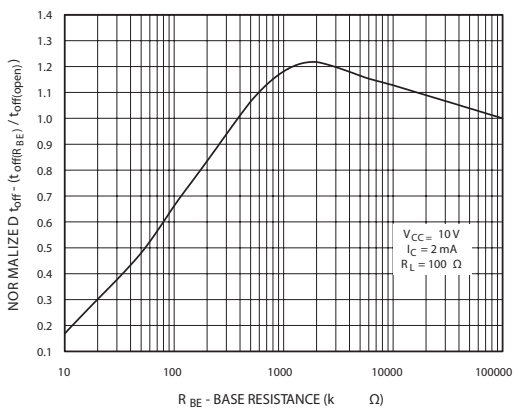

Fig. 18 Normalized t_{off} vs. R_{BE}
(White Package)



GENERAL PURPOSE 6-PIN PHOTOTRANSISTOR OPTOCOUPLERS

4N25
4N37

4N26
H11A1

4N27
H11A2

4N28
H11A3

4N35
H11A4

4N36
H11A5

Fig. 19 Dark Current vs. Ambient Temperature

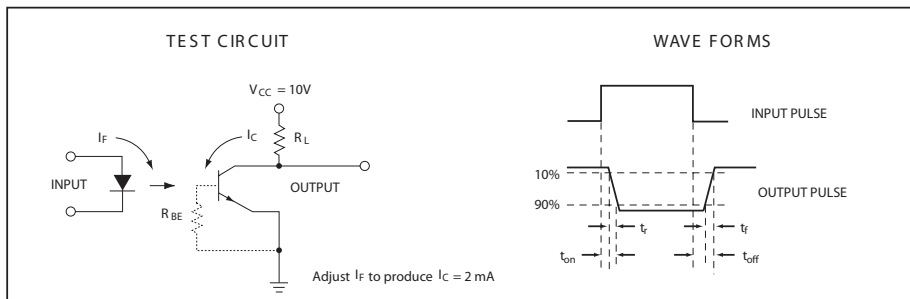
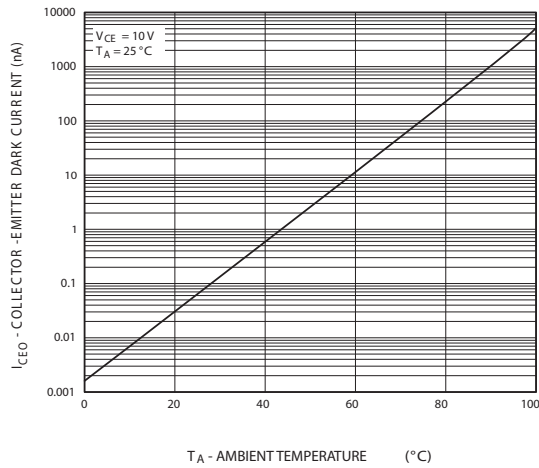

Figure 20. Switching Time Test Circuit and Waveforms

GENERAL PURPOSE 6-PIN PHOTOTRANSISTOR OPTOCOUPLEDERS

4N25
4N37

4N26
H11A1

4N27
H11A2

4N28
H11A3

4N35
H11A4

4N36
H11A5

Black Package (No -M Suffix)

Package Dimensions (Through Hole)

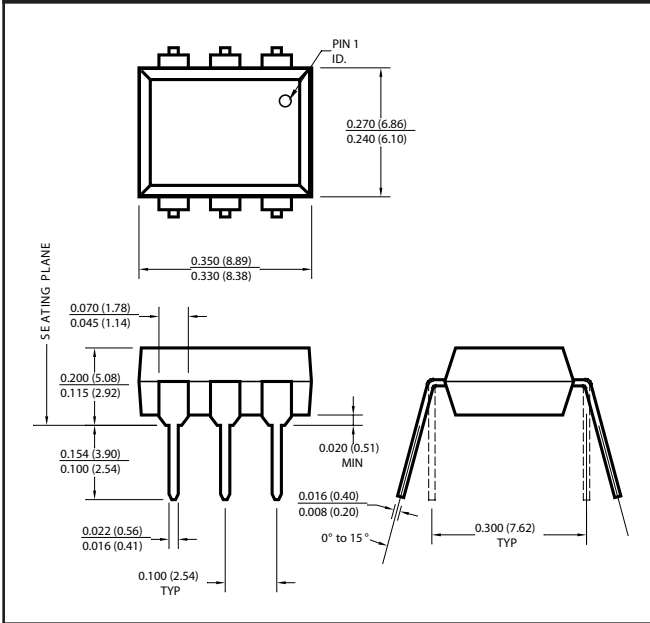

Package Dimensions (Surface Mount)

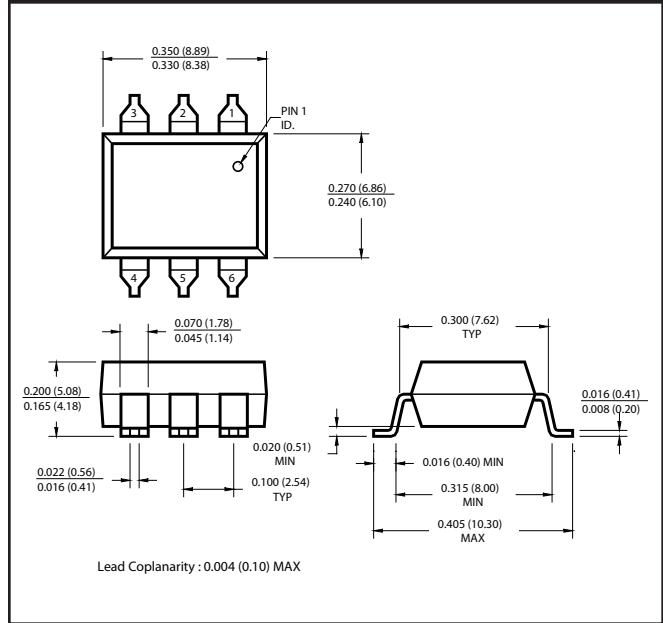

Package Dimensions (0.4" Lead Spacing)

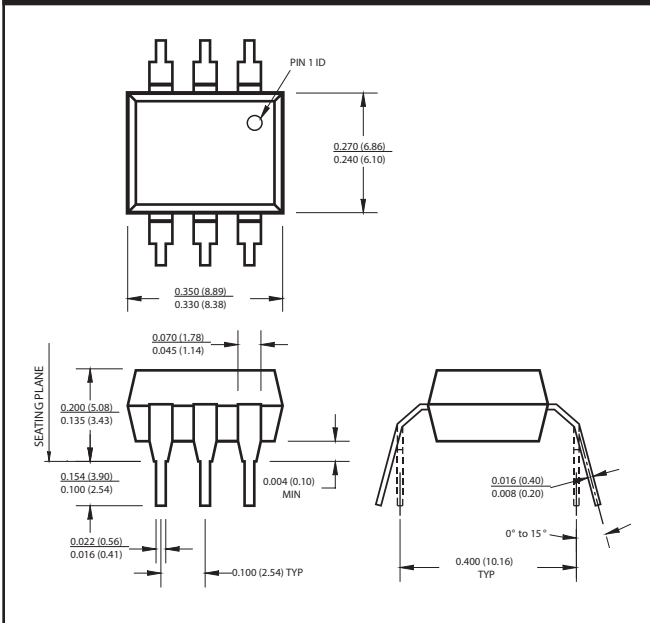

Recommended Pad Layout for Surface Mount Leadform

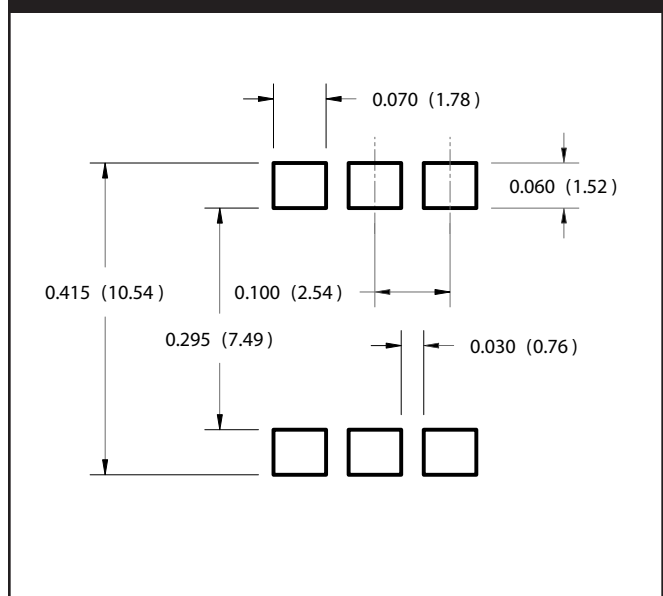

NOTE
All dimensions are in inches (millimeters)

GENERAL PURPOSE 6-PIN PHOTOTRANSISTOR OPTOCOUPLEDERS

4N25
4N37

4N26
H11A1

4N27
H11A2

4N28
H11A3

4N35
H11A4

4N36
H11A5

White Package (-M Suffix)

Package Dimensions (Through Hole)

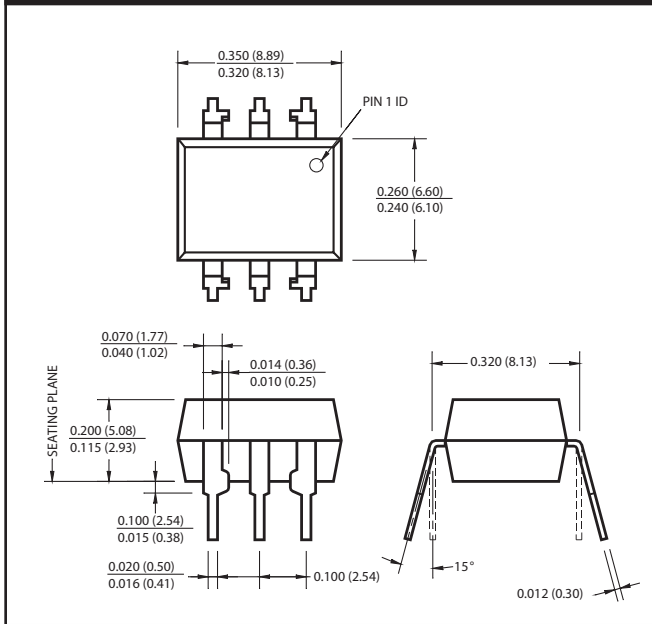

Package Dimensions (Surface Mount)

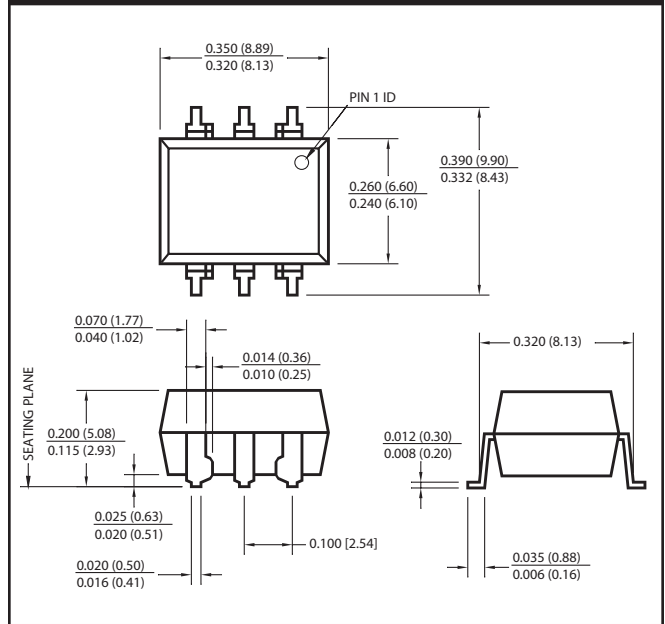

Package Dimensions (0.4" Lead Spacing)

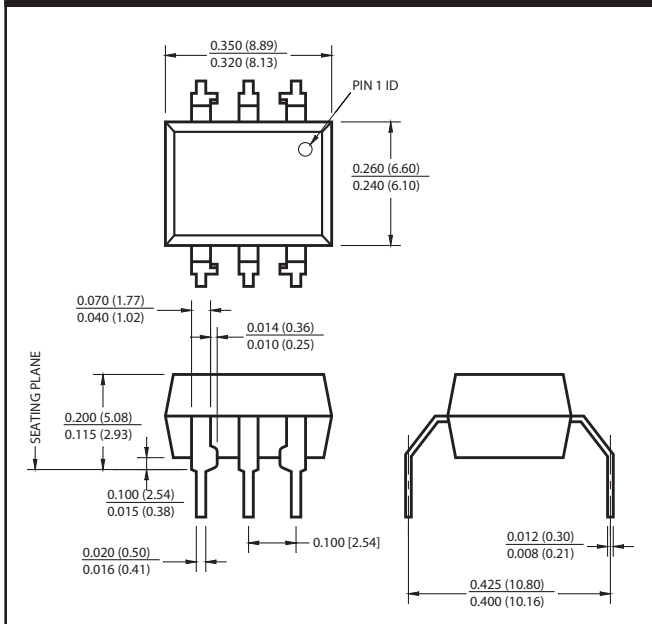

Recommended Pad Layout for Surface Mount Leadform

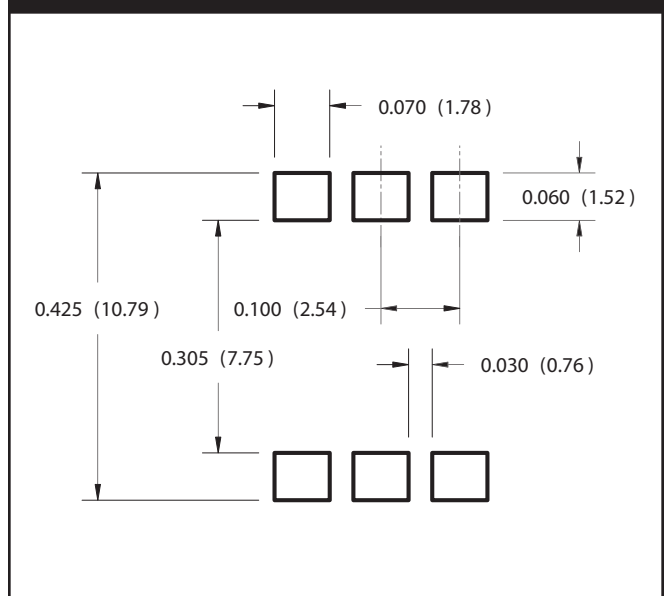

NOTE

All dimensions are in inches (millimeters)

GENERAL PURPOSE 6-PIN PHOTOTRANSISTOR OPTOCOUPLEDERS

4N25 4N37	4N26 H11A1	4N27 H11A2	4N28 H11A3	4N35 H11A4	4N36 H11A5
--------------	---------------	---------------	---------------	---------------	---------------

ORDERING INFORMATION

Order Entry Identifier		
Black Package (No Suffix)	White Package (-M Suffix)	Option
.S	S	Surface Mount Lead Bend
.SD	SR2	Surface Mount; Tape and reel
.W	T	0.4" Lead Spacing
.300	V	VDE 0884
.300W	TV	VDE 0884, 0.4" Lead Spacing
.3S	SV	VDE 0884, Surface Mount
.3SD	SR2V	VDE 0884, Surface Mount, Tape & Reel

QT Carrier Tape Specifications (Black Package, No Suffix)

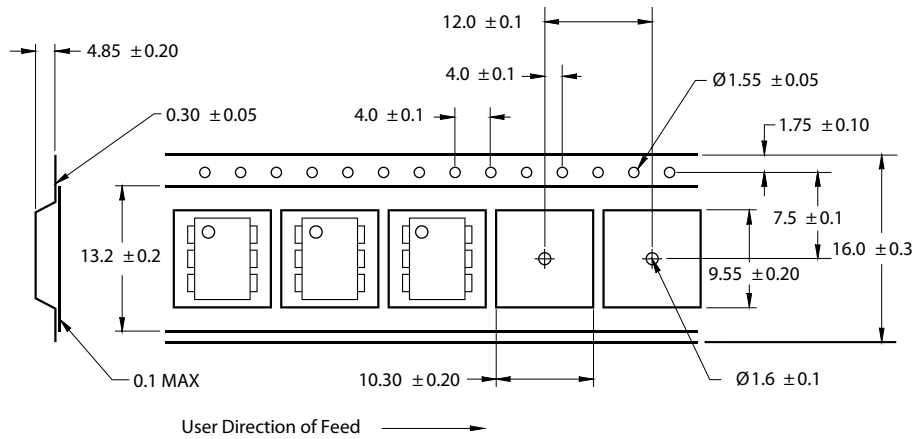

QT Carrier Tape Specifications (White Package, -M Suffix)

