

BGM15LA12

Low-Band LNA Multiplexer Module

Data Sheet

Revision 3.0 - 2015-07-24

Edition 2015-07-24

**Published by Infineon Technologies AG
81726 Munich, Germany**

**©2015 Infineon Technologies AG
All Rights Reserved.**

LEGAL DISCLAIMER

The information given in this document shall in no event be regarded as a guarantee of conditions or characteristics. With respect to any examples or hints given herein, any typical values stated herein and/or any information regarding the application of the device, Infineon Technologies hereby disclaims any and all warranties and liabilities of any kind, including without limitation, warranties of non-infringement of intellectual property rights of any third party.

Information

For further information on technology, delivery terms and conditions and prices, please contact the nearest Infineon Technologies Office (www.infineon.com).

Warnings

Due to technical requirements, components may contain dangerous substances. For information on the types in question, please contact the nearest Infineon Technologies Office. Infineon Technologies components may be used in life-support devices or systems only with the express written approval of Infineon Technologies, if a failure of such components can reasonably be expected to cause the failure of that life-support device or system or to affect the safety or effectiveness of that device or system. Life support devices or systems are intended to be implanted in the human body or to support and/or maintain and sustain and/or protect human life. If they fail, it is reasonable to assume that the health of the user or other persons may be endangered.

Revision History

Document No.: BGM15LA12__v3.0.pdf

Revision History: Rev. v3.0

Previous Version: Preliminary, Revision v2.4 - 2014-08-21

Page	Subjects (major changes since last revision)
all	"Preliminary" status removed
19	Package Outline Drawing: Minimum package height specified
19	Marking Specification added
20	Footprint Recommendation added

Trademarks of Infineon Technologies AG

AURIX™, C166™, CanPAK™, CIPOS™, CIPURSE™, CoolGaN™, CoolMOS™, CoolSET™, CoolSiC™, CORECONTROL™, CROSSAVE™, DAVE™, DI-POL™, DrBLADE™, EasyPIM™, EconoBRIDGE™, EconoDUAL™, EconoPACK™, EconoPIM™, EiceDRIVER™, eupec™, FCOS™, HITFET™, HybridPACK™, ISOFACE™, IsoPACK™, i-Wafer™, MIPAQ™, ModSTACK™, my-d™, NovalithiC™, OmniTune™, OPTIGA™, OptiMOS™, ORIGA™, POWERCODE™, PRIMARION™, PrimePACK™, PrimeSTACK™, PROFET™, PRO-SIL™, RASIC™, REAL3™, ReverSave™, SatRIC™, SIEGET™, SIPMOS™, SmartLEWIS™, SOLID FLASH™, SPOC™, TEMPFET™, thinQ!™, TRENCHSTOP™, TriCore™.

Other Trademarks

Advance Design System™ (ADS) of Agilent Technologies, AMBA™, ARM™, MULTI-ICE™, KEIL™, PRIMECELL™, REALVIEW™, THUMB™, μ Vision™ of ARM Limited, UK. ANSI™ of American National Standards Institute. AUTOSAR™ of AUTOSAR development partnership. Bluetooth™ of Bluetooth SIG Inc. CAT-iq™ of DECT Forum. COLOSSUS™, FirstGPS™ of Trimble Navigation Ltd. EMV™ of EMVCo, LLC (Visa Holdings Inc.). EPCOS™ of Epcos AG. FLEXGO™ of Microsoft Corporation. HYPERTERMINAL™ of Hilgraeve Incorporated. MCS™ of Intel Corp. IEC™ of Commission Electrotechnique Internationale. IrDA™ of Infrared Data Association Corporation. ISO™ of INTERNATIONAL ORGANIZATION FOR STANDARDIZATION. MATLAB™ of MathWorks, Inc. MAXIM™ of Maxim Integrated Products, Inc. MICROTEC™, NUCLEUS™ of Mentor Graphics Corporation. MIPI™ of MIPI Alliance, Inc. MIPS™ of MIPS Technologies, Inc., USA. muRata™ of MURATA MANUFACTURING CO., MICROWAVE OFFICE™ (MWO) of Applied Wave Research Inc., OmniVision™ of OmniVision Technologies, Inc. Openwave™ of Openwave Systems Inc. RED HAT™ of Red Hat, Inc. RFMD™ of RF Micro Devices, Inc. SIRIUS™ of Sirius Satellite Radio Inc. SOLARIS™ of Sun Microsystems, Inc. SPANSION™ of Spansion LLC Ltd. Symbian™ of Symbian Software Limited. TAIYO YUDEN™ of Taiyo Yuden Co. TEAKLITE™ of CEVA, Inc. TEKTRONIX™ of Tektronix Inc. TOKO™ of TOKO KABUSHIKI KAISHA TA. UNIX™ of X/Open Company Limited. VERILOG™, PALLADIUM™ of Cadence Design Systems, Inc. VLYNQ™ of Texas Instruments Incorporated. VXWORKS™, WIND RIVER™ of WIND RIVER SYSTEMS, INC. ZETEX™ of Diodes Zetex.

Last Trademarks Update 2014-07-17

Contents

1 Features	6
2 Product Description	6
3 Maximum Ratings	7
4 DC Characteristics	8
5 RF Characteristics	9
5.1 BAND 8	9
5.2 BAND 12	10
5.3 BAND 20	11
5.4 BAND 26	12
5.5 BAND 28	13
6 MIPI RFFE Specification	14
7 Application Information	20
8 Package Information	22

List of Figures

1 BGM15LA12 Block diagram	7
2 Received clock signal constraints	15
3 Bus active data receiver timing requirements	16
4 Bus park cycle timing	16
5 Bus active data transmission timing specification	17
6 Requirements for VIO-initiated reset	17
7 BGM15LA12 Pin Configuration (top view)	20
8 BGM15LA12 Application Schematic	21
9 ATSLP-12-1 Package Outline (top, side and bottom views)	22
10 Marking Specification (top view)	22
11 Footprint Recommendation	23
12 ATSLP-12-1 Carrier Tape	23

List of Tables

1	Ordering Information	6
2	Maximum Ratings	7
4	DC Characteristics	8
5	RF Characteristics Band 8	9
6	RF Characteristics Band 12	10
7	RF Characteristics Band 20	11
8	RF Characteristics Band 26	12
9	RF Characteristics Band 28	13
10	MIPI Features	14
11	Startup Behavior	14
12	MIPI RFFE operating timing	15
13	Register Mapping	17
14	Truth Table, Register_0	19
15	Pin Definition and Function	20
16	Bill of Materials	21

BGM15LA12 Low-Band LNA Multiplexer Module

1 Features

- Power gain: 17.5 dB
- Low noise figure: 1.1 dB
- Low current consumption: 4.9 mA
- Frequency range from 0.7 to 1.0 GHz
- RF output internally matched to 50 Ω
- Low external component count
- High port-to-port-isolation
- Suitable for LTE / LTE-Advanced and 3G applications
- No decoupling capacitors required if no DC applied on RF lines
- On chip control logic including ESD protection
- Supply voltage: 2.2 to 3.3 V
- Integrated MIPI RFFE interface operating in 1.1 to 1.95 V voltage range
- Software programmable MIPI RFFE USID
- Small form factor 1.1 mm x 1.9 mm
- High EMI robustness
- RoHS and WEEE compliant package

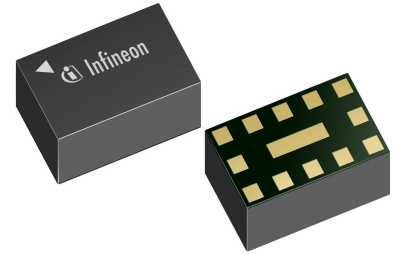

2 Product Description

The BGM15LA12 is a LNA multiplexer module for LTE low-band frequencies that increases the data rate while keeping flexibility and low footprint. It is a perfect solution for multimode handsets based on LTE-Advanced and WCDMA. The BGM15LA12 is controlled via a MIPI RFFE controller. The device configuration is shown in Fig. 12.

Table 1: Ordering Information

Type	Package	Marking
BGM15LA12	ATSLP-12-1	L1

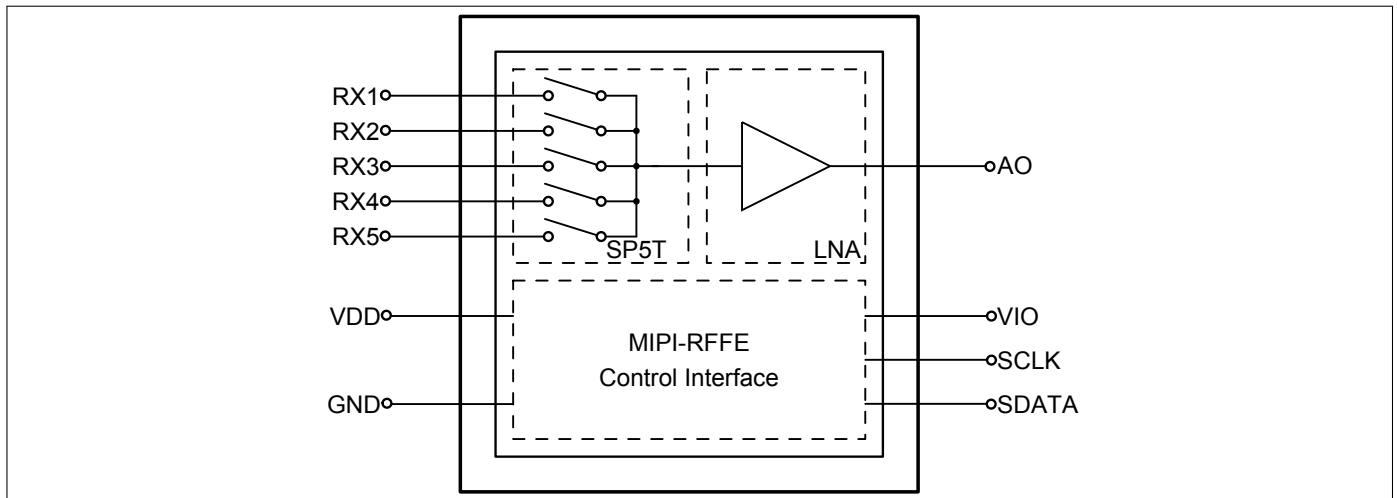
Figure 1: BGM15LA12 Block diagram

3 Maximum Ratings

Table 2: Maximum Ratings

Parameter	Symbol	Values			Unit	Note / Test Condition
		Min.	Typ.	Max.		
Supply Voltage VDD	V_{DD}	-0.3	–	3.6	V	1
Voltage at RF pins Rx	V_{Rx}	-0.3	–	0.9	V	–
Voltage at RF output pin AO	V_{AO}	-0.3	–	$V_{DD}+0.3$	V	–
Voltage at GND pins	V_{GND}	-0.3	–	0.3	V	–
Current into pin VDD	I_{DD}	–	–	16	mA	–
RF input power	P_{IN}	–	–	0	dBm	–
Total power dissipation	P_{tot}	–	–	60	mW	–
Junction temperature	T_J	–	–	150	°C	–
Ambient temperature range	T_A	-40	–	85	°C	–
Storage temperature range	T_{STG}	-65	–	150	°C	–
ESD capability, HBM	V_{ESD_HBM}	–	–	1000	V	according to JESD22A-114
RFFE Supply Voltage	V_{IO}	-0.5	–	3.6	V	–
RFFE Supply Voltage Levels	$V_{SCLK},$ V_{SDATA}	-0.7	–	$V_{IO}+0.7$ (max. 3.6)	V	–

¹ All voltages refer to GND-Nodes unless otherwise noted

Attention: Stresses above the max. values listed here may cause permanent damage to the device. Exposure to absolute maximum rating conditions for extended periods may affect device reliability. Maximum ratings are absolute ratings; exceeding only one of these values may cause irreversible damage to the integrated circuit.

4 DC Characteristics

Table 4: DC Characteristics at $T_A = 25\text{ °C}$

Parameter ¹	Symbol	Values			Unit	Note / Test Condition
		Min.	Typ.	Max.		
Supply Voltage	V_{DD}	2.2	–	3.3	V	–
Supply Current	I_{DD}	–	4.9	5.9	mA	ON-mode
		–	0.1	2	μA	OFF-Mode
RFFE supply voltage	V_{IO}	1.1	1.8	1.95	V	–
RFFE input high voltage ²	V_{IH}	$0.7 \cdot V_{IO}$	–	V_{IO}	V	–
RFFE input low voltage ²	V_{IL}	0	–	$0.3 \cdot V_{IO}$	V	–
RFFE output high voltage ²	V_{OH}	$0.8 \cdot V_{IO}$	–	V_{IO}	V	–
RFFE output low voltage ²	V_{OL}	0	–	$0.2 \cdot V_{IO}$	V	–
RFFE control input capacitance	C_{Ctrl}	–	–	2	pF	–
RFFE supply current	I_{VIO}	–	15	–	μA	Idle State

¹Based on the application described in Chapter 7

²SCLK and SDATA

5 RF Characteristics

5.1 BAND 8

Table 5: RF Characteristics Band 8 at $T_A = 25\text{ }^\circ\text{C}$, $V_{DD} = 2.8\text{ V}$, $f = 925 - 960\text{ MHz}$, with matching described in Chapter 7 ($C=1.1\text{ pF}$, $L=11\text{ nH}$)

Parameter ¹	Symbol	Values			Unit	Note / Test Condition
		Min.	Typ.	Max.		
Insertion power gain ²	$ S_{21} ^2$	14.3	15.8	17.3	dB	–
Noise figure ²	NF	–	1.1	1.6	dB	$Z_S=50\ \Omega$
Input return loss ^{2 3}	RL_{in}	8	11	–	dB	–
Output return loss ^{2 3}	RL_{out}	12	>20	–	dB	–
Reverse isolation AO to RX port ^{2 3}	$1/ S_{12} ^2$	19	23	–	dB	–
Inband input 1dB-compression point ^{2 3}	IP_{1dB}	-11	-8	–	dBm	–
Inband input 3 rd -order intercept point ^{2 3 4}	IIP_3	-4	-1	–	dBm	$f_1=937\text{ MHz}$, $f_2=947\text{ MHz}$, $f_{12}=927\text{ MHz}$
Isolation RX to RX port ^{2 5}	ISO	35	40	–	dB	
Isolation RX to AO port ^{2 5}	ISO	24	29	–	dB	forward direction
Stability ⁵	k	>1	–	–		$f=20\text{ MHz}–10\text{ GHz}$
RF Rise Time RX Port On/Off ⁵	$t_{on/off}$	0.5	1	5	μs	10% to 90% ON; 90% to 10% ON
Power Up Settling Time ⁵	t_{BC}	–	10	25	μs	After power down mode

¹The parameter values are valid at any RX port using the matching described in Chapter 7

²PCB losses are subtracted

³Verification based on AQL; not 100% tested in production

⁴Input power = -30 dBm for each tone

⁵Guaranteed by device design; not tested in production

5.2 BAND 12

Table 6: RF Characteristics Band 12 at $T_A = 25\text{ °C}$, $V_{DD} = 2.8\text{ V}$, $f = 729 - 746\text{ MHz}$, with matching described in Chapter 7 (C=2.2 pF, L=16 nH)

Parameter ¹	Symbol	Values			Unit	Note / Test Condition
		Min.	Typ.	Max.		
Insertion power gain ²	$ S_{21} ^2$	15.2	16.7	18.2	dB	–
Noise figure ²	NF	–	1.2	1.7	dB	$Z_S=50\ \Omega$
Input return loss ^{2 3}	RL_{in}	8	11	–	dB	–
Output return loss ^{2 3}	RL_{out}	8	12	–	dB	–
Reverse isolation AO to RX port ^{2 3}	$1/ S_{12} ^2$	19	23	–	dB	–
Inband input 1dB-compression point ^{2 3}	IP_{1dB}	-14	-11	–	dBm	–
Inband input 3 rd -order intercept point ^{2 3 4}	IIP_3	-7	-4	–	dBm	$f_1=732\text{ MHz}$, $f_2=742\text{ MHz}$, $f_{12}=722\text{ MHz}$
Isolation RX to RX port ^{2 5}	ISO	34	39	–	dB	
Isolation RX to AO port ^{2 5}	ISO	24	29	–	dB	forward direction
Stability ⁵	k	>1	–	–		$f=20\text{ MHz}–10\text{ GHz}$
RF Rise Time RX Port On/Off ⁵	$t_{on/off}$	0.5	1	5	μs	10% to 90% ON; 90% to 10% ON
Power Up Settling Time ⁵	t_{BC}	–	10	25	μs	After power down mode

¹The parameter values are valid at any RX port using the matching described in Chapter 7

²PCB losses are subtracted

³Verification based on AQL; not 100% tested in production

⁴Input power = –30 dBm for each tone

⁵Guaranteed by device design; not tested in production

5.3 BAND 20

Table 7: RF Characteristics Band 20 at $T_A = 25\text{ °C}$, $V_{DD} = 2.8\text{ V}$, $f = 791 - 821\text{ MHz}$, with matching described in Chapter 7 ($C=1.8\text{ pF}$, $L=15\text{ nH}$)

Parameter ¹	Symbol	Values			Unit	Note / Test Condition
		Min.	Typ.	Max.		
Insertion power gain ²	$ S_{21} ^2$	15	16.5	18	dB	–
Noise figure ²	NF	–	1.15	1.65	dB	$Z_S=50\ \Omega$
Input return loss ^{2 3}	RL_{in}	8	11	–	dB	–
Output return loss ^{2 3}	RL_{out}	11	19	–	dB	–
Reverse isolation AO to RX port ^{2 3}	$1/ S_{12} ^2$	20	24	–	dB	–
Inband input 1dB-compression point ^{2 3}	IP_{1dB}	-13	-10	–	dBm	–
Inband input 3 rd -order intercept point ^{2 3 4}	IIP_3	-5	-2	–	dBm	$f_1=801\text{ MHz}$, $f_2=811\text{ MHz}$, $f_{12}=791\text{ MHz}$
Isolation RX to RX port ^{2 5}	ISO	34	39	–	dB	
Isolation RX to AO port ^{2 5}	ISO	24	29	–	dB	forward direction
Stability ⁵	k	>1	–	–		$f=20\text{ MHz}–10\text{ GHz}$
RF Rise Time RX Port On/Off ⁵	$t_{on/off}$	0.5	1	5	μs	10% to 90% ON; 90% to 10% ON
Power Up Settling Time ⁵	t_{BC}	–	10	25	μs	After power down mode

¹The parameter values are valid at any RX port using the matching described in Chapter 7

²PCB losses are subtracted

³Verification based on AQL; not 100% tested in production

⁴Input power = –30 dBm for each tone

⁵Guaranteed by device design; not tested in production

5.4 BAND 26

Table 8: RF Characteristics Band 26 at $T_A = 25\text{ °C}$, $V_{DD} = 2.8\text{ V}$, $f = 859 - 894\text{ MHz}$, with matching described in Chapter 7 ($C=1.5\text{ pF}$, $L=13\text{ nH}$)

Parameter ¹	Symbol	Values			Unit	Note / Test Condition
		Min.	Typ.	Max.		
Insertion power gain ²	$ S_{21} ^2$	14.8	16.3	17.8	dB	–
Noise figure ²	NF	–	1.2	1.7	dB	$Z_S=50\ \Omega$
Input return loss ^{2 3}	RL_{in}	8	11	–	dB	–
Output return loss ^{2 3}	RL_{out}	12	>20	–	dB	–
Reverse isolation AO to RX port ^{2 3}	$1/ S_{12} ^2$	19	23	–	dB	–
Inband input 1dB-compression point ^{2 3}	IP_{1dB}	-11	-8	–	dBm	–
Inband input 3 rd -order intercept point ^{2 3 4}	IIP_3	-4	-1	–	dBm	$f_1=871\text{ MHz}$, $f_2=881\text{ MHz}$, $f_{12}=861\text{ MHz}$
Isolation RX to RX port ^{2 5}	ISO	34	39	–	dB	
Isolation RX to AO port ^{2 5}	ISO	24	29	–	dB	forward direction
Stability ⁵	k	>1	–	–		$f=20\text{ MHz}-10\text{ GHz}$
RF Rise Time RX Port On/Off ⁵	$t_{on/off}$	0.5	1	5	μs	10% to 90% ON; 90% to 10% ON
Power Up Settling Time ⁵	t_{BC}	–	10	25	μs	After power down mode

¹The parameter values are valid at any RX port using the matching described in Chapter 7

²PCB losses are subtracted

³Verification based on AQL; not 100% tested in production

⁴Input power = -30 dBm for each tone

⁵Guaranteed by device design; not tested in production

5.5 BAND 28

Table 9: RF Characteristics Band 28 at $T_A = 25\text{ °C}$, $V_{DD} = 2.8\text{ V}$, $f = 758 - 803\text{ MHz}$, with matching described in Chapter 7 ($C=2\text{ pF}$, $L=16\text{ nH}$)

Parameter ¹	Symbol	Values			Unit	Note / Test Condition
		Min.	Typ.	Max.		
Insertion power gain ²	$ S_{21} ^2$	15.1	16.6	18.1	dB	–
Noise figure ²	NF	–	1.1	1.6	dB	$Z_S=50\ \Omega$
Input return loss ^{2 3}	RL_{in}	8	11	–	dB	–
Output return loss ^{2 3}	RL_{out}	11	16	–	dB	–
Reverse isolation AO to RX port ^{2 3}	$1/ S_{12} ^2$	21	25	–	dB	–
Inband input 1dB-compression point ^{2 3}	IP_{1dB}	-13	-10	–	dBm	–
Inband input 3 rd -order intercept point ^{2 3 4}	IIP_3	-6	-3	–	dBm	$f_1=775\text{ MHz}$, $f_2=785\text{ MHz}$, $f_{12}=765\text{ MHz}$
Isolation RX to RX port ^{2 5}	ISO	34	39	–	dB	
Isolation RX to AO port ^{2 5}	ISO	24	29	–	dB	forward direction
Stability ⁵	k	>1	–	–		$f=20\text{ MHz}-10\text{ GHz}$
RF Rise Time RX Port On/Off ⁵	$t_{on/off}$	0.5	1	5	μs	10% to 90% ON; 90% to 10% ON
Power Up Settling Time ⁵	t_{BC}	–	10	25	μs	After power down mode

¹The parameter values are valid at any RX port using the matching described in Chapter 7

²PCB losses are subtracted

³Verification based on AQL; not 100% tested in production

⁴Input power = -30 dBm for each tone

⁵Guaranteed by device design; not tested in production

6 MIPI RFFE Specification

All sequences are implemented according to the 'MIPI Alliance Specification for RF Front-End Control Interface' document version 1.10 - 26. July 2011.

Table 10: MIPI Features

Feature	Supported	Comment
Register write command sequence	Yes	
Register read command sequence	Yes	
Extended register write command sequence	No	Up to 4 Bytes
Extended register read command sequence	No	Up to 4 Bytes
Register 0 write command sequence	Yes	
Trigger function	Yes	Trigger assignment to each control register is supported
Programmable USID	Yes	3 register command sequence and extended register command sequence
Status Register	Yes	Register for debugging
Reset	Yes	By VIO, Power Mode and RFFE_STATUS
Group SID	Yes	
USID_Sel pin	No	External pin for changing USID is not implemented
Full speed write	Yes	
Half speed read	Yes	
Full speed read	Yes	

Table 11: Startup Behavior

Feature	State	Comment
Power status	LOW POWER	The chip is in low power mode after startup
Trigger function	ENABLED	Trigger function is enabled after startup. Trigger function can be disabled via PM_TRIG register.

Table 12: MIPI RFFE Operating Timing

Parameter	Symbol	Values			Unit	Note / Test Condition
		Min.	Typ.	Max.		
SCLK Frequency	FSCLK	0.032	–	26	MHz	Full speed
		0.032	–	13	MHz	Half speed
SCLK Period	TSCLK	0.038	–	32	μ s	Full speed
		0.077	–	32	μ s	Half speed
SCLK Low Period	TSCLKIL	11.25	–	–	ns	Full speed, see Fig. 2
		24	–	–	ns	Half speed, see Fig. 2
SCLK High Period	TSCLKIH	11.25	–	–	ns	Full speed, see Fig. 2
		24	–	–	ns	Half speed, see Fig. 2
SDATA Setup Time	TS	1	–	–	ns	Full speed, see Fig. 3
		2	–	–	ns	Half speed, see Fig. 3
SDATA Hold Time	TH	5	–	–	ns	Full speed, see Fig. 3
		5	–	–	ns	Half speed, see Fig. 3
SDATA Release Time	TSDATAZ	–	–	10	ns	Full speed, see Fig. 4
		–	–	18	ns	Half speed, see Fig. 4
Time for Data Output	TD	–	–	10.25	ns	Full speed, see Fig. 5
		–	–	22	ns	Half speed, see Fig. 5
SDATA Rise/Fall Time	TSDATAOTR	2.1	–	6.5	ns	Full speed, see Fig. 5
		2.1	–	10	ns	Half speed, see Fig. 5
VIO Rise Time	TVIO-R	10	–	450	μ s	See Fig. 6
VIO Reset Time	TVIO-RST	10	–	–	μ s	See Fig. 6
Reset Delay Time	TSIGOL	0.12	–	–	μ s	See Fig. 6

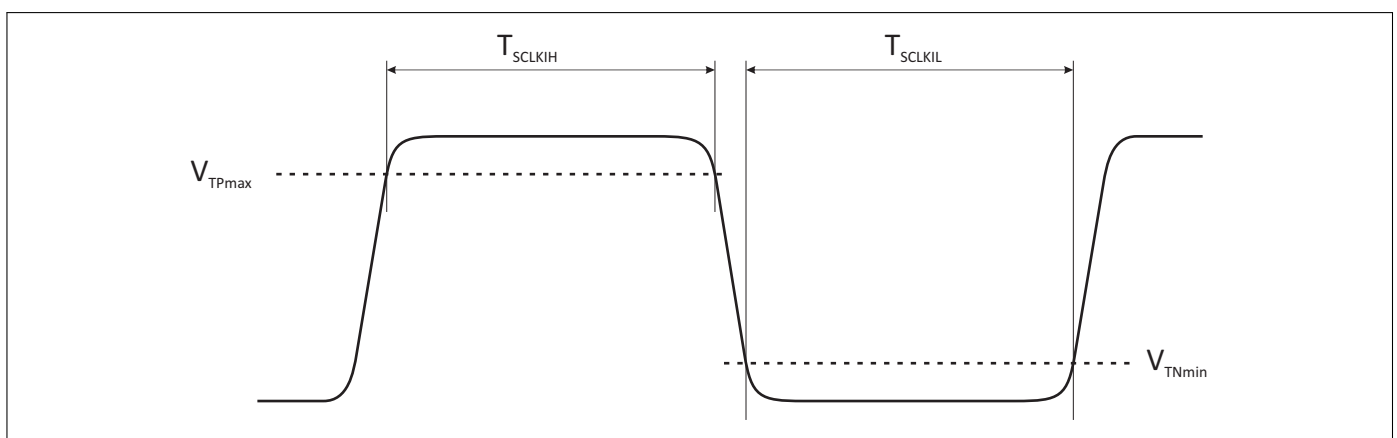
Figure 2: Received clock signal constraints

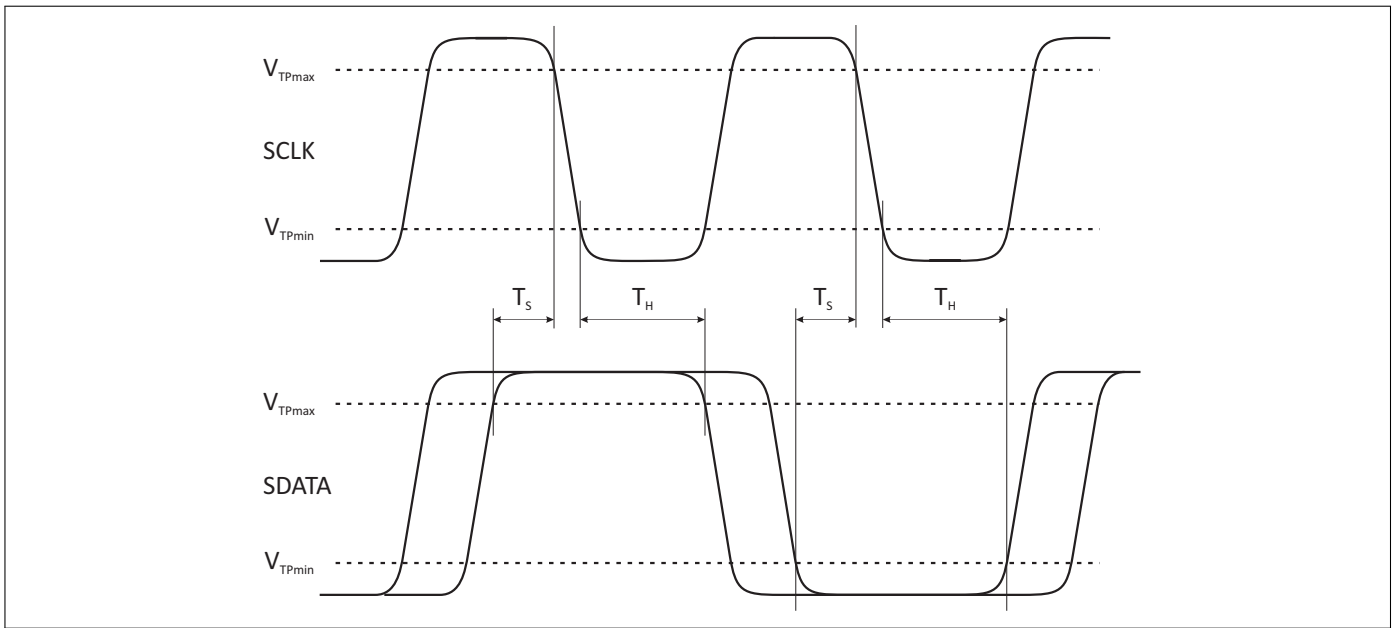

Figure 3: Bus active data receiver timing requirements

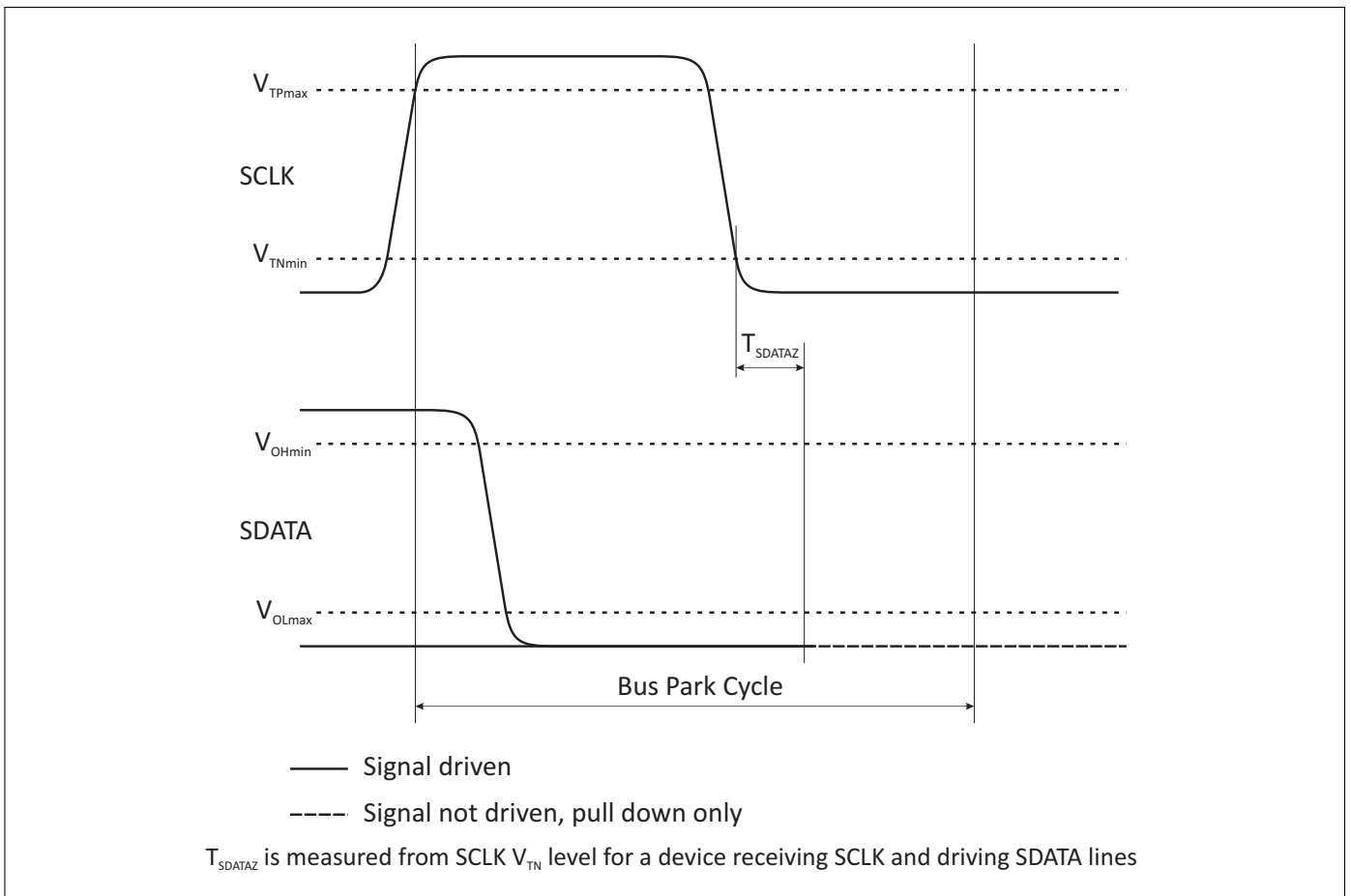

Figure 4: Bus park cycle timing

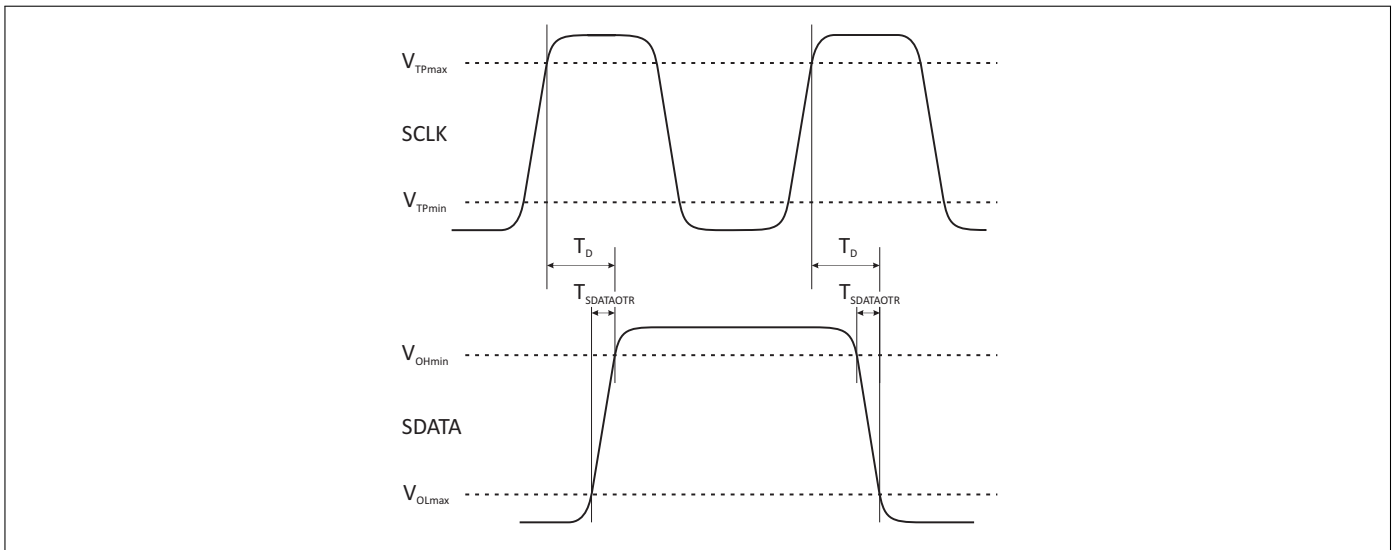

Figure 5: Bus active data transmission timing specification

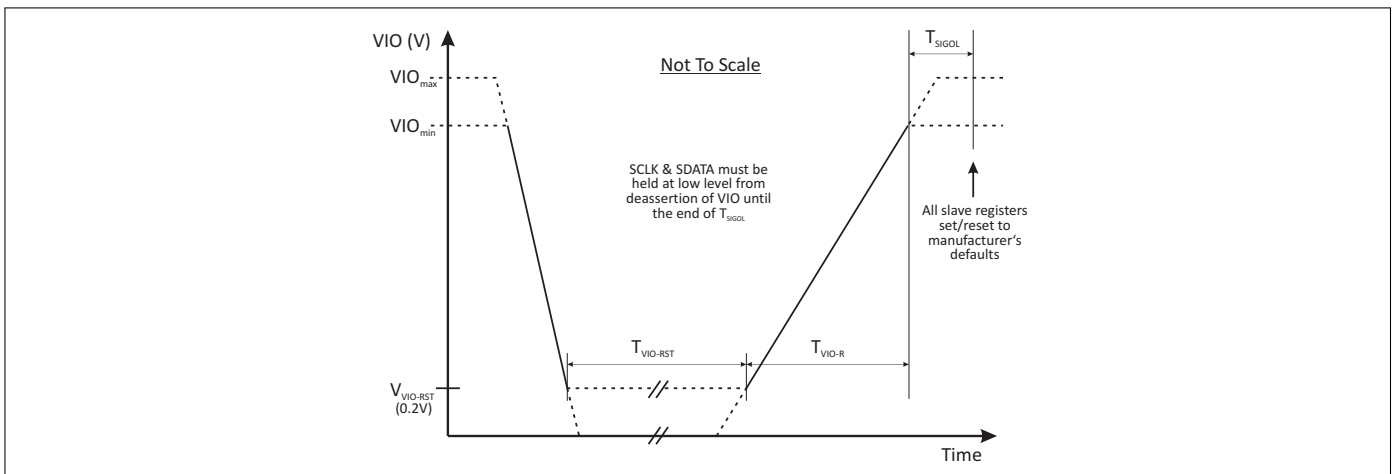

Figure 6: Requirements for VIO-initiated reset

Table 13: Register Mapping

Register Address	Register Name	Data Bits	Function	Description	Default	Broadcast_ID Support	Trigger Support	R/W
0x0000	REGISTER_0	7:0	MODE_CTRL	Module control	00000000	No	Yes	R/W
0x001D	PRODUCT_ID	7:0	PRODUCT_ID	This is a read-only register. However, during the programming of the USID a write command sequence is performed on this register, even though the write does not change its value.	11010001	No	No	R
0x001E	MANUFACTURER_ID	7:0	MANUFACTURER_ID [7:0]	This is a read-only register. However, during the programming of the USID, a write command sequence is performed on this register, even though the write does not change its value.	00011010	No	No	R

Continued on next page

Table 13: Register Mapping – Continued from previous page

Register Address	Register Name	Data Bits	Function	Description	Default	Broadcast_ID Support	Trigger Support	R/W
0x001C	PM_TRIG	7:6	PWR_MODE	00: Normal operation 01: Default settings (STARTUP) 10: Low power (LOW POWER) 11: Reserved	10	Yes	No	R/W
		5	TRIGGER_MASK_2	If this bit is set, trigger 2 is disabled. When all triggers disabled, if writing to a register that is associated to trigger 2, the data goes directly to the destination register.	0	No	No	
		4	TRIGGER_MASK_1	If this bit is set, trigger 1 is disabled. When all triggers disabled, if writing to a register that is associated to trigger 1, the data goes directly to the destination register.	0	No	No	
		3	TRIGGER_MASK_0	If this bit is set, trigger 0 is disabled. When all triggers disabled, if writing to a register that is associated to trigger 0, the data goes directly to the destination register.	0	No	No	
		2	TRIGGER_2	A write of a one to this bit loads trigger 2's registers.	0	Yes	No	
		1	TRIGGER_1	A write of a one to this bit loads trigger 1's registers.	0	Yes	No	R/W
		0	TRIGGER_0	A write of a one to this bit loads trigger 0's registers.	0	Yes	No	
0x001F	MAN_USID	7:6	SPARE	These are read-only bits that are reserved and yield a value of 0b00 at readback.	00	No	No	R/W
		5:4	MANUFACTURER_ID [9:8]	These bits are read-only. However, during the programming of the USID, a write command sequence is performed on this register even though the write does not change its value.	01			
		3:0	USID	Programmable USID. Performing a write to this register using the described programming sequences will program the USID in devices supporting this feature. These bits store the USID of the device.	0001			
0x001A	RFFE_STATUS	7	SOFTWARE RESET	0: Normal operation 1: Software reset	0	No	No	R/W
		6	COMMAND_FRAME_PARITY_ERR	Command sequence received with parity error - discard command.	0	No	No	R
		5	COMMAND_LENGTH_ERR	Command length error	0			
		4	ADDRESS_FRAME_PARITY_ERR	Address frame parity error = 1	0			
		3	DATA_FRAME_PARITY_ERR	Data frame with parity error	0			
		2	READ_UNUSED_REG	Read command to an invalid address	0			
		1	WRITE_UNUSED_REG	Write command to an invalid address	0			
		0	BID_GID_ERR	Read command with a BROADCAST_ID or GROUP_SID	0			
0x001B	GROUP_SID	7:4	RESERVED		0	No	No	R/W
		3:0	GROUP_SID	Group slave ID	0			

Table 14: Modes of Operation (Truth Table, Register_0)

State	Mode	REGISTER_0 Bits							
		D7	D6	D5	D4	D3	D2	D1	D0
1	Isolation	x	x	x	0	0	0	0	0
2	RX1-AO	x	x	x	0	0	0	0	1
3	RX2-AO	x	x	x	0	0	0	1	0
4	RX3-AO	x	x	x	0	1	0	0	0
5	RX4-AO	x	x	x	0	0	1	0	0
6	RX5-AO	x	x	x	1	0	0	0	0
7	RX1&RX2-AO	x	x	x	0	0	0	1	1
8	RX2&RX3-AO	x	x	x	0	1	0	1	0
9	RX3&RX4-AO	x	x	x	0	1	1	0	0
10	RX4&RX5-AO	x	x	x	1	0	1	0	0
11	RX1&RX3-AO	x	x	x	0	1	0	0	1
12	RX2&RX4-AO	x	x	x	0	0	1	1	0
13	RX3&RX5-AO	x	x	x	1	1	0	0	0
14	RX1&RX4-AO	x	x	x	0	0	1	0	1
15	RX2&RX5-AO	x	x	x	1	0	0	1	0
16	RX1&RX5-AO	x	x	x	1	0	0	0	1

7 Application Information

Pin Configuration and Function

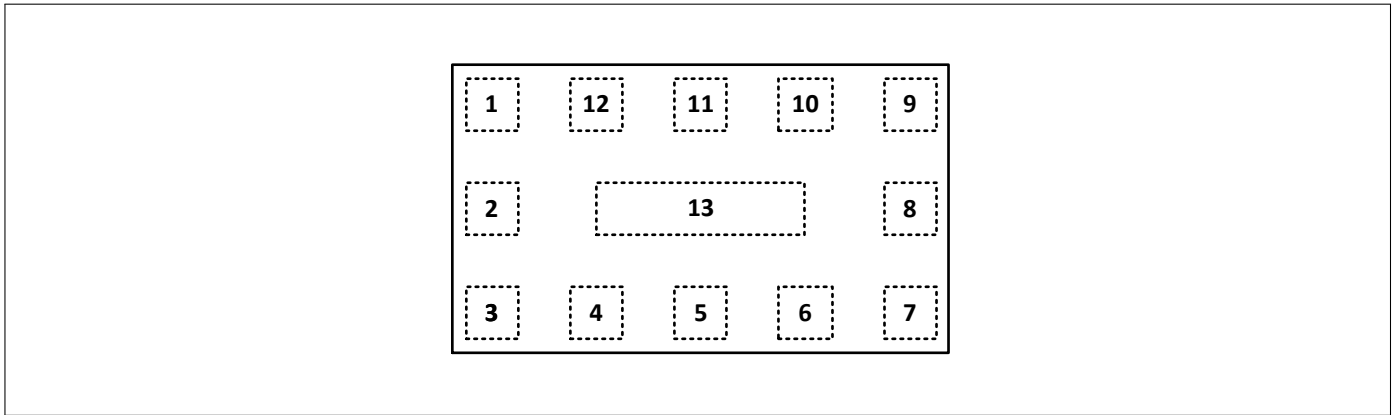

Figure 7: BGM15LA12 Pin Configuration (top view)

Table 15: Pin Definition and Function

Pin No.	Name	Function
1	SCLK	MIPI RFFE Clock
2	VIO	MIPI RFFE Power Supply
3	RX5	RF-Port RX No. 5
4	RX4	RF-Port RX No. 4
5	RX3	RF-Port RX No. 3
6	RX2	RF-Port RX No. 2
7	RX1	RF-Port RX No. 1
8	GND	Ground
9	GND	Ground
10	AO	RF-Output Port
11	VDD	Power Supply
12	SDATA	MIPI RFFE Data IO
13	GND	Ground

Application Board Configuration

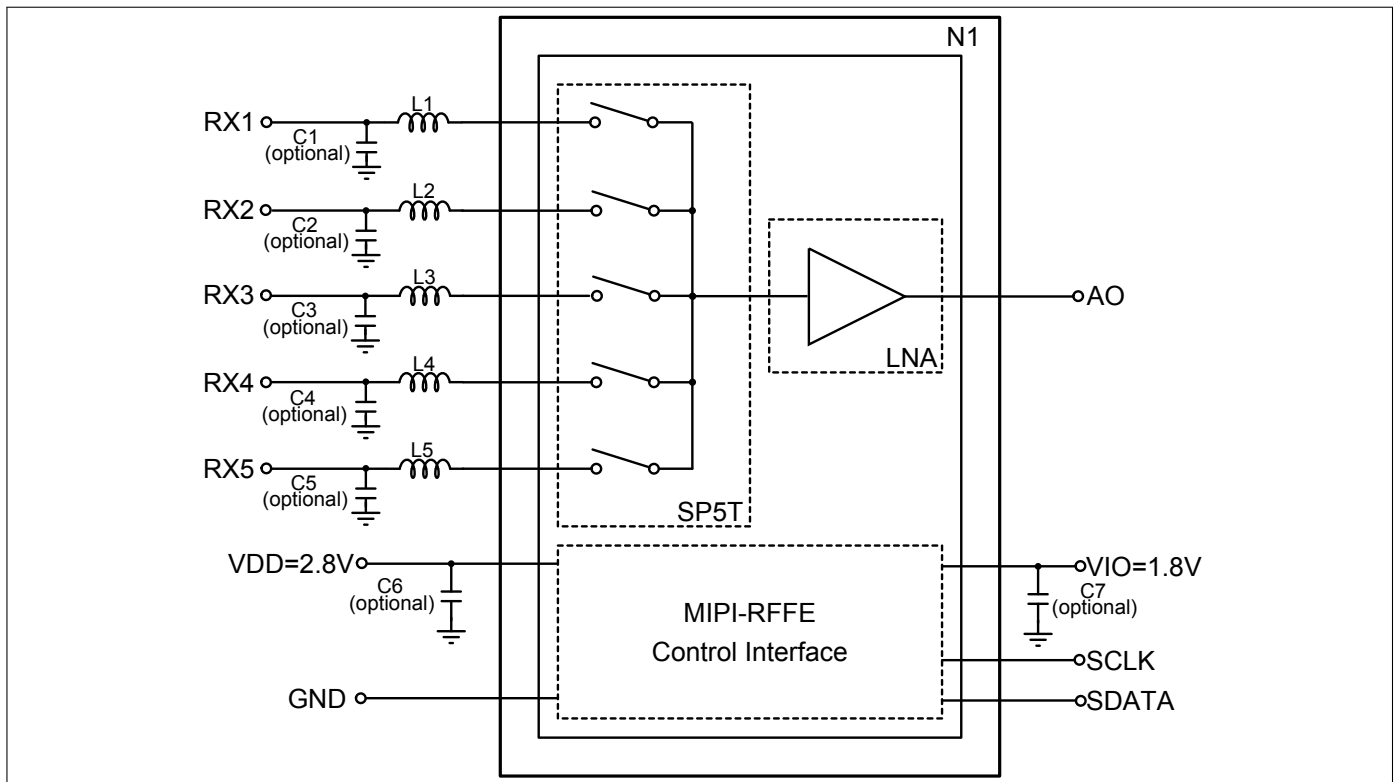

Figure 8: BGM15LA12 Application Schematic

Table 16: Bill of Materials Table

Name	Value	Package	Manufacturer	Function
C1 (optional)	2 pF	0402	Various	Input matching Band 28 ²⁾
C2 (optional)	1.1 pF	0402	Various	Input matching Band 8 ²⁾
C3 (optional)	1.8 pF	0402	Various	Input matching Band 20 ²⁾
C4 (optional)	2.2 pF	0402	Various	Input matching Band 12 ²⁾
C5 (optional)	1.5 pF	0402	Various	Input matching Band 26 ²⁾
C6 (optional)	1 nF	0402	Various	RF Bypass ¹⁾
C7 (optional)	1 nF	0402	Various	RF Bypass ¹⁾
L1	16 nH	0402	Various	Input matching Band 28 ²⁾
L2	11 nH	0402	Various	Input matching Band 8 ²⁾
L3	15 nH	0402	Various	Input matching Band 20 ²⁾
L4	18 nH	0402	Various	Input matching Band 12 ²⁾
L5	13 nH	0402	Various	Input matching Band 26 ²⁾
N1	BGM15LA12	ATSLP-12-1	Infineon	LNA Multiplexer Module

¹⁾RF bypass recommended to mitigate power supply noise.

²⁾The matching elements must be optimized with reference to the frequency band of interest. Each band can be arbitrarily assigned to an RF port. The configuration shown in the table is only an example of the port assignment.

8 Package Information

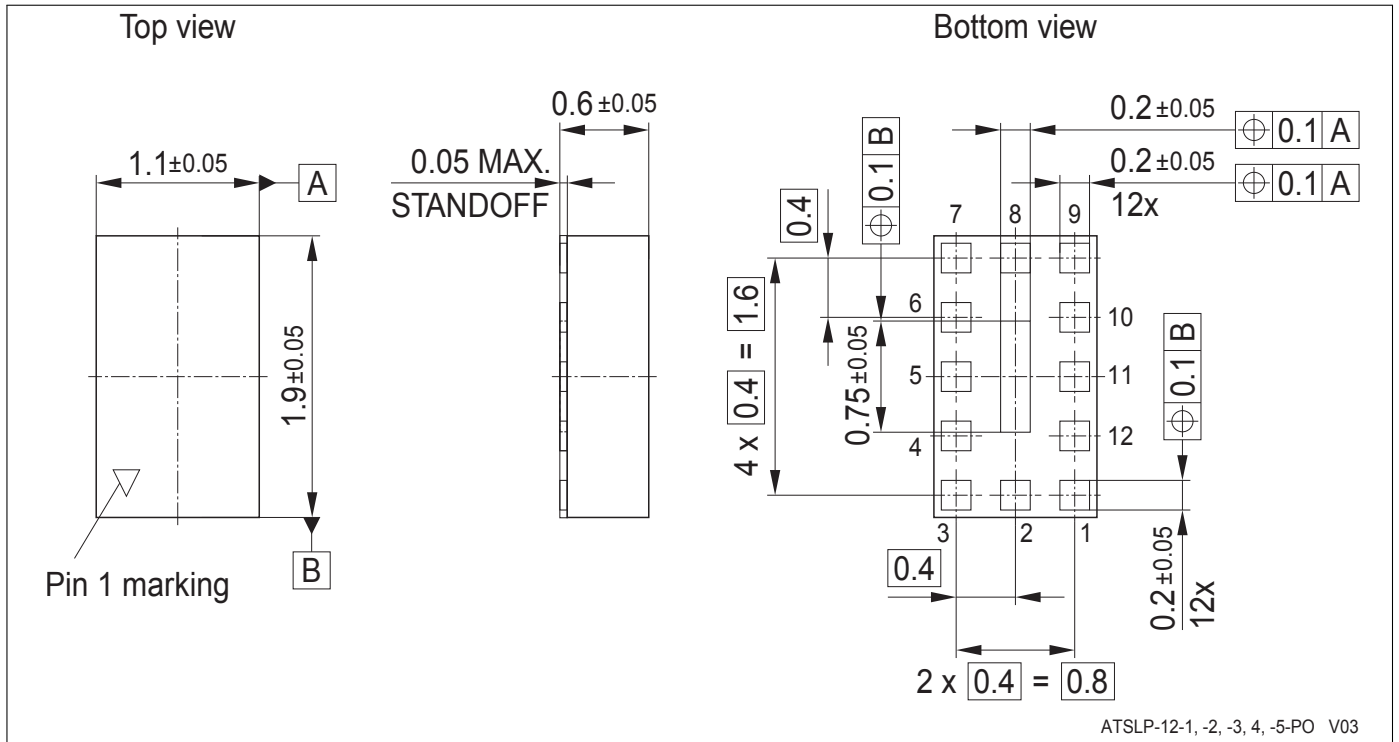

Figure 9: ATSLP-12-1 Package Outline (top, side and bottom views)

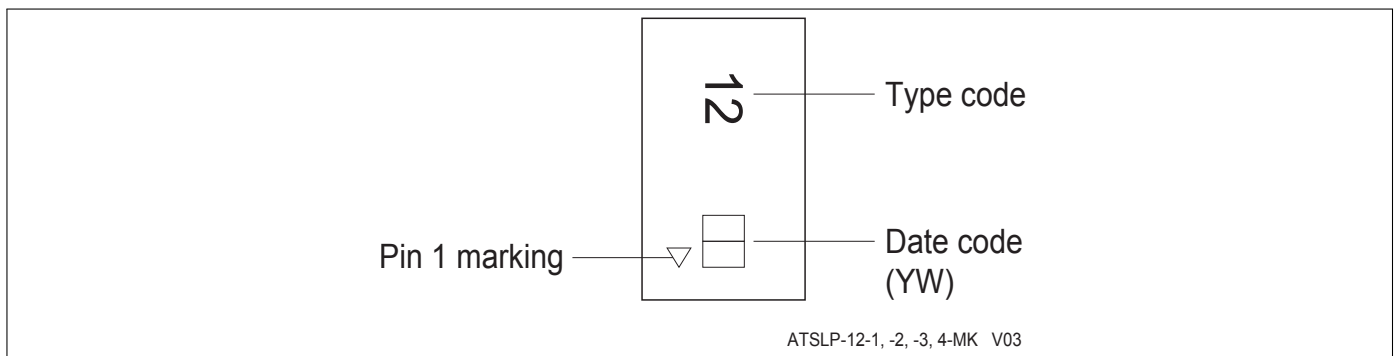

Figure 10: Marking Specification (top view)

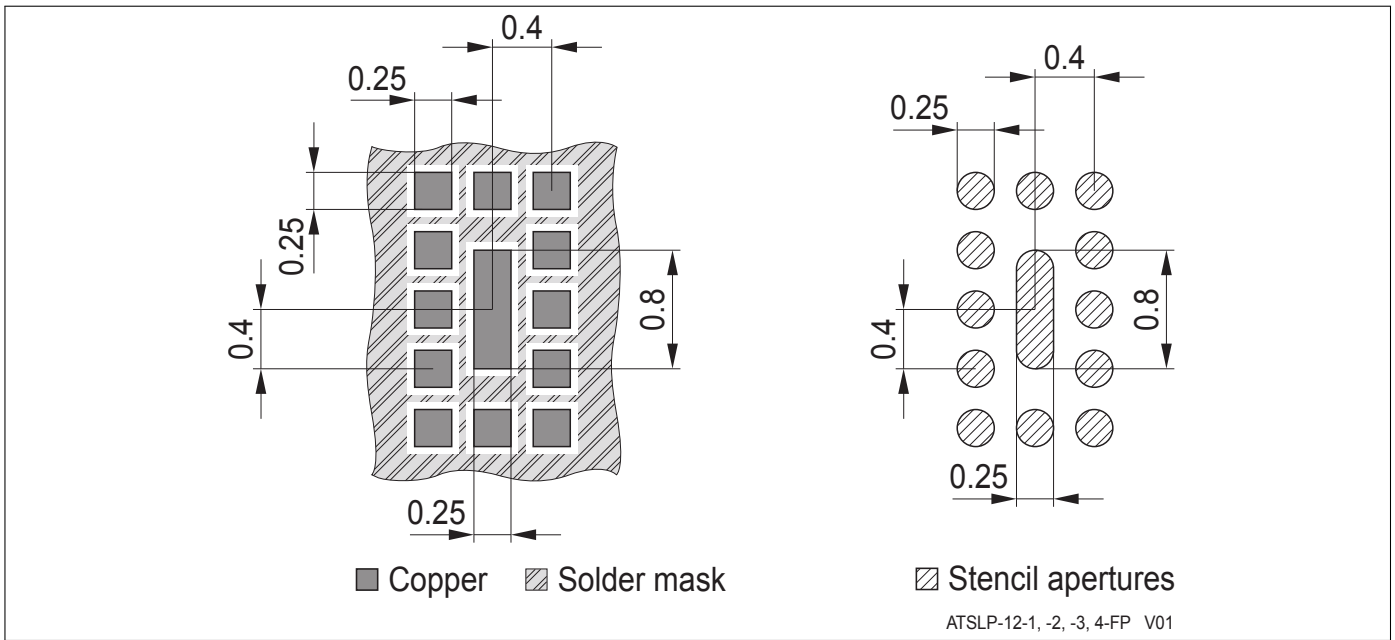

Figure 11: Footprint Recommendation

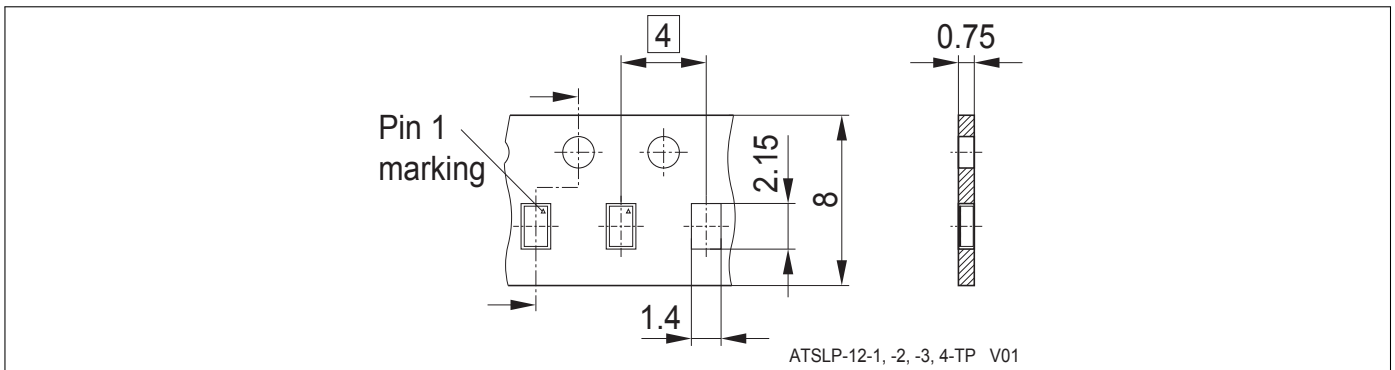

Figure 12: ATSLP-12-1 Carrier Tape

www.infineon.com

Published by Infineon Technologies AG