

## 10/100 BASE-T TRANSFORMER

## P/N: 14ST9012P LF DATA SHEET

## Feature

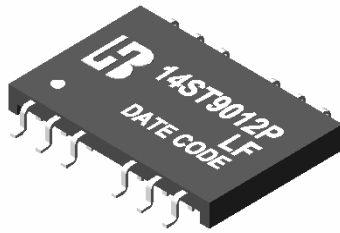

- Design for 10/100 MB/s TX & ATM 155 MB/s applications.
- Very low profile PCMCIA SMD package.
- Comply with RoHS requirements-whole part No Cd, No Hg, No Cr6+, No PBB and PBDE and No Pb on external pins.
- Operating temperature range: 0 to +70 .
- Storage temperature range: -25 to +125 .

## Electrical Specifications @ 25°C

Part Number	Turns Ratio (±5%)		OCL (uH Min) @ 100KHz/0.1V with 8mA DC Bias	L.L (uH Max)	C <sub>ww</sub> (pF Max)	Insertion Loss (dB Max) 0.3-100MHz	HI-POT (Vrms)
	TX	RX					
14ST9012P LF	1CT:1CT	1CT:1CT	350	0.35	28	-1.3	1500

## Continue

Part Number	Return Loss (dB Min)			Cross talk (dB Min)			DCMR (dB Min) TX/RX			
	30MHz	60MHz	80MHz	30MHz	60MHz	100MHz	30MHz	50MHz	100MHz	150MHz
14ST9012P LF	-18	-13	-11	-40	-40	-35	-40	-35	-30	-20

## Schematic

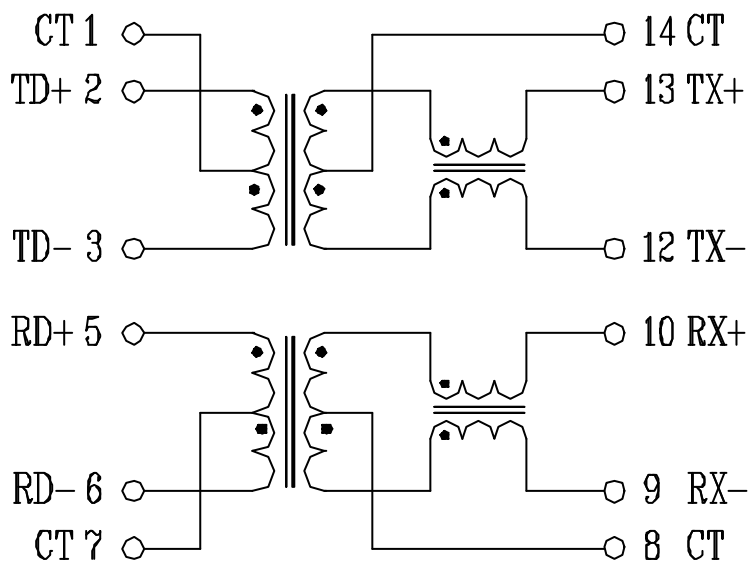

**10/100 BASE-T TRANSFORMER**  
**P/N: 14ST9012P LF DATA SHEET**

**Mechanical**

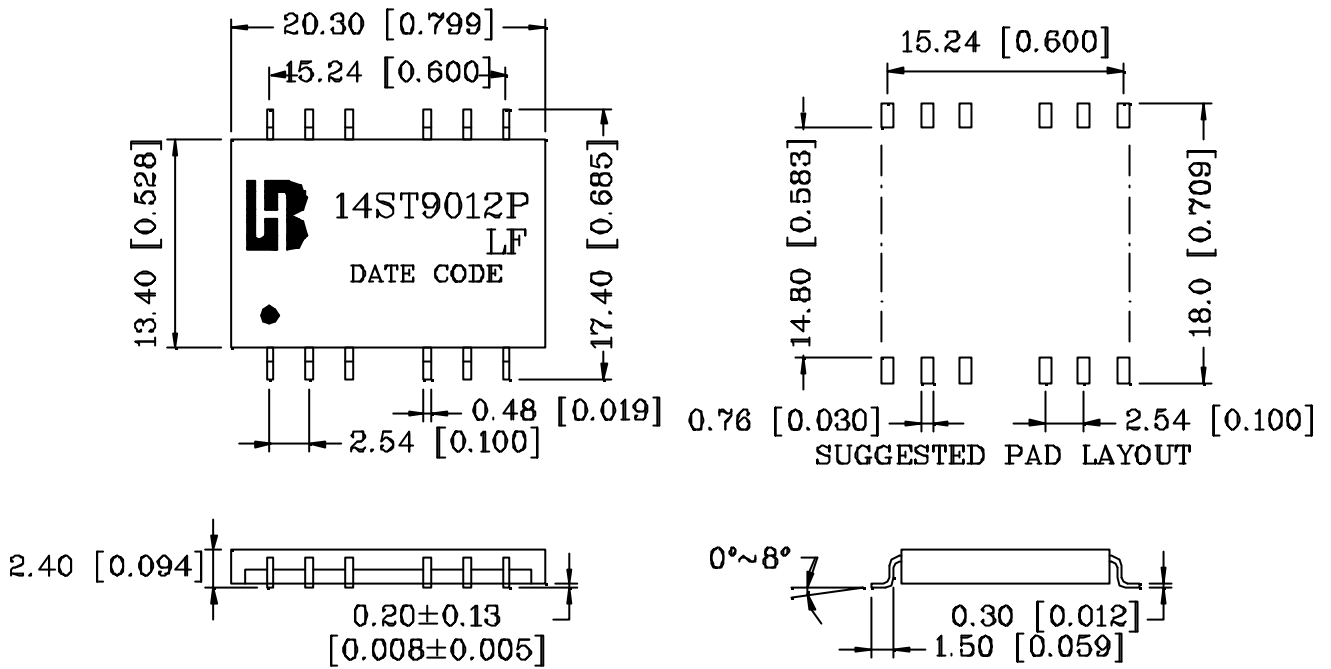

Units: mm[Inches] Tolerances: xx.x0±0.25[0.010]  
0.xx±0.05[0.002]